

Series H Heavy Duty Industrial Hydraulic Cylinders

Catalog AC1140-3
March, 2006



ATLAS
CYLINDERS

ESP Series Cylinders

Operating Pressure to 3000 PSI



Electronic Stroke Positioning heavy duty cylinders with resolution to .0005", operating pressure to 3000 PSI.

EM Series Cylinders

Operating Pressure to 3000 PSI



Remote Electronics with resolution to .0005", operating pressure to 3000 PSI. Electronic module change out without removing or disassembly of the cylinder.

MH Series Cylinders

Standard Operating Pressure to 2000 PSI



Mill Hydraulic with bolted head construction, standard operating pressure to 2000 PSI and modified to 3000 PSI. Only standard non tie rod Mill Cylinder to meet NFPA interchange.

Custom Cylinders



Bores to 42" and Strokes to 900". Full range of offering from micro cylinders to cylinders over 40,000 lbs.

Warning

FAILURE OR IMPROPER SELECTION OR IMPROPER USE OF THE PRODUCTS AND/OR SYSTEMS DESCRIBED HEREIN OR RELATED ITEMS CAN CAUSE DEATH, PERSONAL INJURY AND PROPERTY DAMAGE.

This document and other information from The Company, its subsidiaries and authorized distributors provide product and/or system options for further investigation by users having technical expertise. It is important that you analyze all aspects of your application, including consequences of any failure and review the information concerning the product or system in the current product catalog. Due to the variety of operating conditions and applications for these products or systems, the user, through its own analysis and testing, is solely responsible for making the final selection of the products and systems and assuring that all performance, safety and warning requirements of the application are met.

The product described herein, including without limitation, product features, specifications, designs, availability and pricing, are subject to change by The Company and its subsidiaries at any time without notice.

Offer of Sale

The items described in this document are hereby offered for sale by The Company, its subsidiaries or its authorized distributors. This offer and its acceptance are governed by provisions stated on a [separate page](#) of this catalog in the document entitled 'Offer of Sale'.

Table of Contents	Page		
Specifications, Mounting Styles	3		
Cylinder Features	4, 5, 19		
	Bore Sizes		
	1 1/2" to 6"	7" & 8"	10" - 20"
Styles NM1, NM2, NM3 Tie Rods Extended Mounts (Both Ends NFPA MX1, Cap End NFPA MX2, Head End NFPA MX3)	6, 7	20, 21	36, 37
Style REF2, Head Rectangular Flange Mount (NFPA MF1)	8, 9	22, 23	N/A
Style REF1, Head Square Flange Mount (NFPA MF5)	8, 9	22, 23	N/A
Style ME5, Head Rectangular Mount (NFPA ME5)	8, 9	22, 23	38, 39
Style IH3, Head Square Flange Mount (NFPA MF5)	N/A	N/A	38, 39
Style BEF2, Cap Rectangular Flange Mount (NFPA MF2)	10, 11	24, 25	N/A
Style BEF1, Cap Square Flange Mount (NFPA MF2)	10, 11	24, 25	N/A
Style ME6, Cap Rectangular Mount (NFPA ME6)	10, 11	24, 25	40, 41
Style IH4, Cap Square Flange Mount (NFPA MF6)	N/A	N/A	40, 41
Style SL, Side Lug Mount (NFPA MS2)	12, 13	26, 27	40, 41
Style FS, Side Tap Mount (NFPA MS4)	12, 13	26, 27	N/A
Style PB2, Cap Fixed Clevis Mount (NFPA MP1)	14, 15	28, 29	42, 43
Style TM1, Head Trunnion Mount (NFPA MT1)	16, 17	30, 31	42, 43
Style TM2, Cap Trunnion Mount (NFPA MT2)	16, 17	30, 31	42, 43
Style TM3, Intermediate Trunnion Mount (NFPA MT4)	16, 17	30, 31	42, 43
Style SA, Spherical Bearing Mount (NFPA MPU3)	50, 53	N/A	N/A
Double Rod End Cylinders, B & R Table	32, 44		
Linear Alignment Couplers	45		
Cylinder Accessories	46-49		
Spherical Bearing Mount	50-52		
Spherical Bearing Mount Accessories	53		
"Style 5" Piston Rod End, Split Couplers & Weld Plates	54, 55		
Push and Pull Forces	56		
Operating Fluids and Temperature Range	57		
Cylinder Pressure Ratings, Cylinder Weights	58, 59		
Ports	60, 61		
Stroke Data	62		
Tie Rod Supports	62		
Stroke Adjusters	62		
Stop Tube, Mounting Classes	63		
Piston Rod Selection Chart and Data	64, 65		
Thrust Key Mountings	66		
Rod Gland Drain	66		
End-of-Stroke Magnetic Principle Type Proximity Switch	67		
Parts List, Seal Kits, and Maintenance Instructions	68-70, 72, 73		
How to Order an Atlas Cylinder	74, 75		
Cylinders for Wood Products Applications	75		
Cylinder Safety Guide	76, 77		
Offer of Sale	IBC		

Atlas Series H Heavy-Duty Hydraulic Cylinder

When the application demands a heavy-duty cylinder with maximum performance, specify Atlas Series H. This cylinder has standard design features to maximize machine uptime. The standard bronze rod gland, case-hardened piston rod, high strength piston rod stud and tie rod material combine to make Series H the cylinder for demanding applications up to 3000 psi.

Thorough inspection and performance testing of each cylinder before shipment assure Series H cylinder quality. See the following pages for the inside story on all the features that make Series H the high performance, long lasting choice for all your heavy-duty hydraulic applications.



Standard Specifications

- Heavy Duty Service – ANSI/(NFPA) T3.6.7R2-1996 Mounting and Specification Dimensions
- Standard Construction – Square Head – Tie Rod Design
- Nominal Pressure – 3000 P.S.I.*
- Standard Fluid – Hydraulic Oil
- Standard Temperature – -10° F to +165° F
- Bore Sizes – 1½" through 6"
- Piston Rod Diameter – 5/8" through 4"
- Mounting Styles – 16 standard styles at various application ratings

- Standard – Externally removable bolted gland assembly
- Strokes – Available in any practical stroke length
- Cushions – Optional at either end or both ends of stroke. "Float Check" at cap end.
- Rod Ends – Four Standard Choices – Specials to Order

* If hydraulic operating pressure exceeds 3000 P.S.I., send application data for engineering evaluation and recommendation. See page 58 for actual design factors.

In line with our policy of continuing product improvement, specifications in this catalog are subject to change.

Mounting Styles

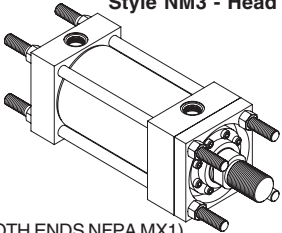
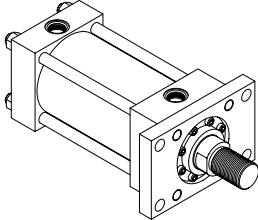
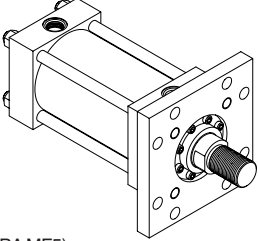
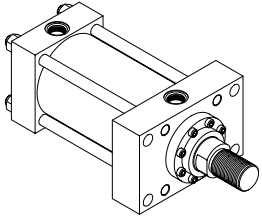
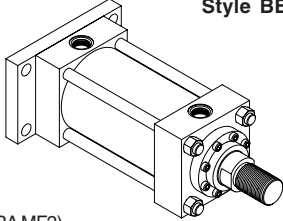
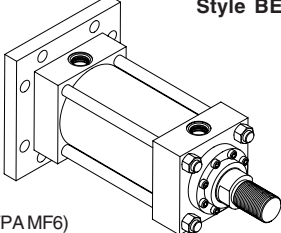
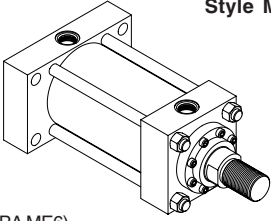
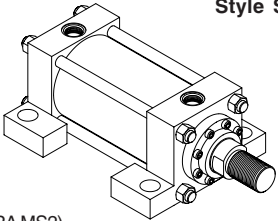
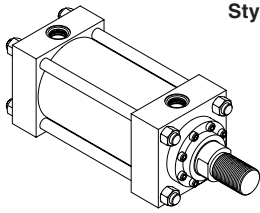
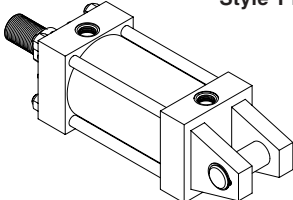
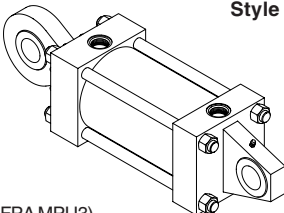
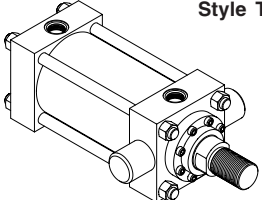
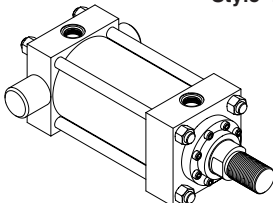
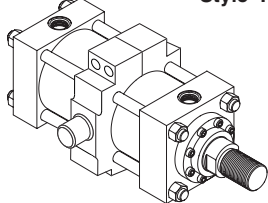
<p>Tie Rods Extended Style NM1 - Both Ends Style NM2 - Cap End Style NM3 - Head End</p>  <p>(BOTH ENDS NFPA MX1) (CAP END NFPA MX2) (HEAD END NFPA MX3)</p>	<p>Head Rectangular Flange Style REF2</p>  <p>(NFPA MF1)</p>	<p>Head Square Flange Style REF1</p>  <p>(NFPA MF5)</p>	<p>Head Rectangular Style ME5</p>  <p>(NFPA ME5)</p>
<p>Cap Rectangular Flange Style BEF2</p>  <p>(NFPA MF2)</p>	<p>Cap Square Flange Style BEF1</p>  <p>(NFPA MF6)</p>	<p>Cap Rectangular Style ME6</p>  <p>(NFPA ME6)</p>	<p>Side Lug Style SL</p>  <p>(NFPA MS2)</p>
<p>Side Tap Style FS</p>  <p>(NFPA MS4)</p>	<p>Cap Fixed Clevis Style PB2</p>  <p>(NFPA MP1)</p>	<p>Cap Fixed Eye with Spherical Bearing Style SA</p>  <p>(NFPA MPU3)</p>	<p>Head Trunnion Style TM1</p>  <p>(NFPA MT1)</p>
<p>Cap Trunnion Style TM2</p>  <p>(NFPA MT2)</p>	<p>Intermediate Trunnion Style TM3</p>  <p>(NFPA MT4)</p>		

Atlas . . . Series H – your best choice in heavy duty hydraulic cylinders

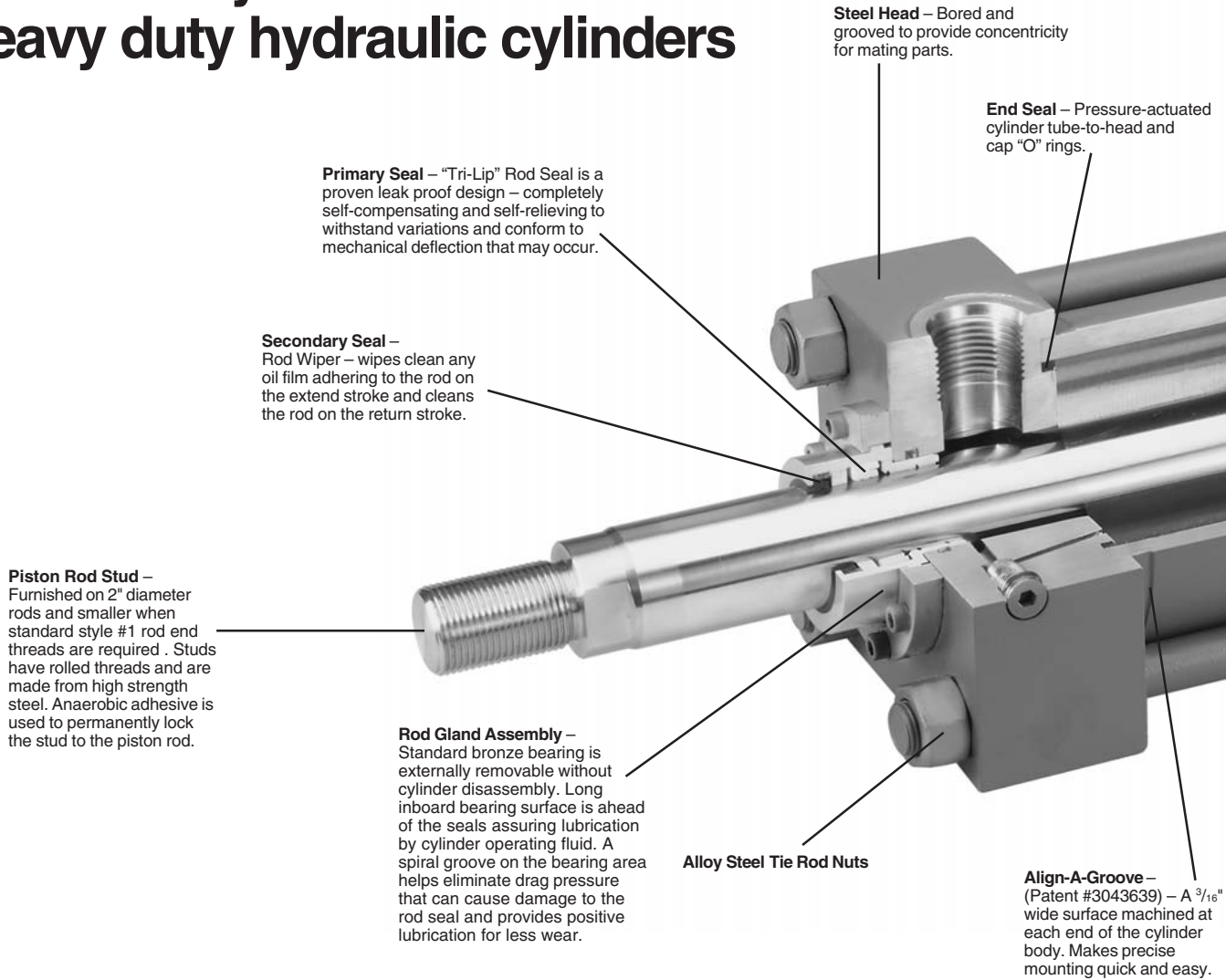

Stepped floating cushions combine the best features of known cushion technology.

Deceleration devices or built-in “cushions” are optional and can be supplied at head end, cap end, or both ends without change in envelope or mounting dimensions. Atlas cylinder cushions are a stepped design and combine the best features of known cushion technology.

Standard straight or tapered cushions have been used in industrial cylinders over a very broad range of applications, extensive research has found that both designs have their limitations.

As a result, we have taken a new approach in cushioning of industrial hydraulic cylinders and for specific load and velocity conditions have been able to obtain deceleration curves that come very close to the ideal. The success lies in a stepped sleeve or spear concept where the steps are calculated to approximate theoretical orifice areas curves.

In the cushion performance chart, pressure traces show the results of typical orifice flow conditions. Tests of a three-step sleeve or spear show three pressure pulses coinciding with the steps. The deceleration curve shape comes very close to being theoretical, with the exception of the last $\frac{1}{2}$ inch of travel.

This is a constant shape in order to have some flexibility in application. The stepped cushion design shows reduced pressure peaks for most load and speed conditions, with comparable reduction of objectionable stopping forces being transmitted to the load and the support structure.

All Atlas H cushions are adjustable.

The Series H cylinder design incorporates the longest cushion sleeves or cushion spears that can be provided in the standard envelope without decreasing the rod bearing and piston bearing lengths.

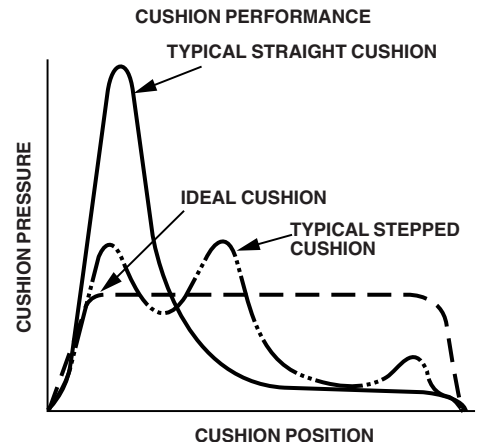

Piston Rod – Medium carbon steel, induction case-hardened, hard chrome-plated and polished to 10 RMS finish.

Adjustable Floating Stepped Cushions – For maximum performance – economical and flexible for even the most demanding applications – provides superior performance in reducing shock. Cushions are optional and can be supplied at head end, cap end, or both ends without change in envelope or mounting dimensions.

Ports – S.A.E. “O”-ring ports are standard

OPTIONAL PORTS

Ports – N.P.T.F. ports are optional at no extra charge. Oversize N.P.T.F. and S.A.E. ports are available at extra charge.

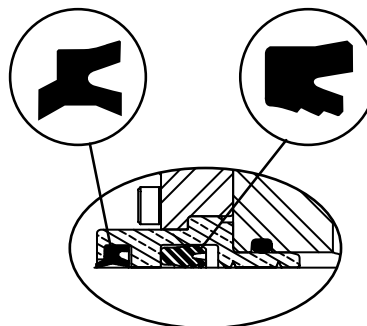

Atlas Gland Assembly with “Tri-Lip” Rod Seal

Gland Assembly externally removable without cylinder disassembly. An O-ring is used as a seal between the gland and head. The “Tri-Lip” rod seal has multiple sealing edges to produce “dry rod” performance. It is molded from a special polyurethane material that is extremely resistant to abrasion and extrusion, resulting in exceptional service life. Wiperseal cleans rod of dirt, preventing it from entering the gland and also acts as a secondary rod seal.

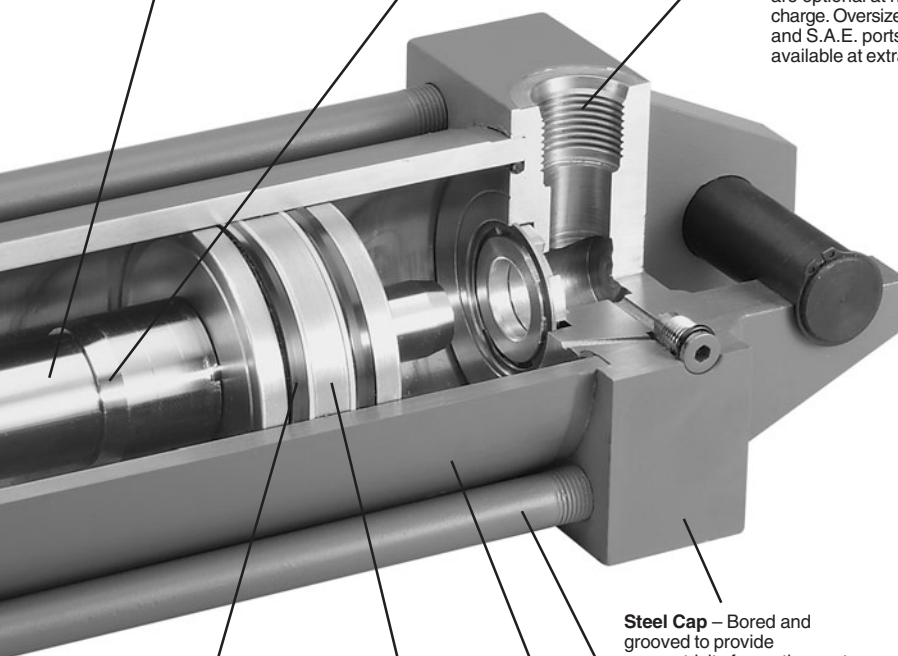

Lipseal® Piston – Zero leakage under static conditions for hydraulic pressures up to 3000 PSI. Seals are self-compensating to conform to variations in pressure, mechanical deflection, and wear. Back-up washer prevents extrusion.

Steel Cap – Bored and grooved to provide concentricity for mating parts.

High Strength Tie Rods – Made from 100,000 PSI minimum yield steel with rolled threads for added strength.

One-Piece Nodular Iron Piston – The wide piston surface contacting cylinder bore reduces bearing loads. Anaerobic adhesive is used to permanently lock and seal the piston to the rod.

The Cylinder Barrel – Heavy-wall steel tubing, honed to a micro finish bore.

OPTIONAL PISTONS

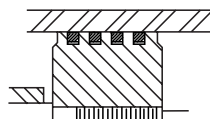

Step cut iron piston rings are optional.

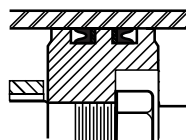

Piston with Retainer Nut – Optional at no extra charge.

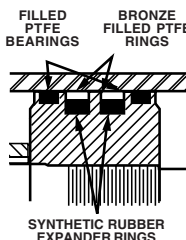

Hi Load Piston – Optional at extra charge (1½-6 inch bores). Includes wear rings and bronze-filled PTFE seals. Two wear rings serve as bearings which deform radially under side-loading, enabling the load to be spread over a larger area and reduce unit loading. Bronze-filled PTFE seals are designed for extrusion-free, leak-proof service and longer cylinder life than the lipseal type piston. Not available with retainer nut.

(1) When a cushion is specified at the head end:

- a. A self-centering stepped sleeve is furnished on the piston rod assembly.
- b. A needle valve is provided that is flush with the side of the head even when wide open. It may be identified by the fact that it is socket-keyed. It is located on side number 2, in all mounting styles except ME5, ME6, TM1, TM2 and TM3. In these styles it is located on side number 3.
- c. On 6" bore and larger cylinders, a springless check valve is provided that is also flush with the side of the head and is mounted adjacent to the needle valve except on mounting style SL, where it is mounted opposite the needle valve. It may be identified by the fact that it is slotted.
- d. On 1½" - 5" bore cylinders a slotted sleeve design is used in place of the check valve.
- e. 1½" - 2½" bore cylinders use cartridge style needle valve (see Figure A).

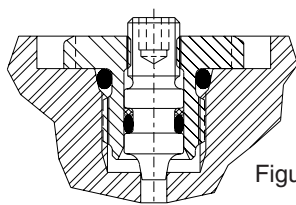
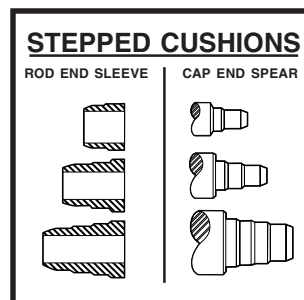

Figure A

(2) When a cushion is specified at the cap end:

- a. A stepped spear is provided on the piston rod.
- b. A “float check” self-centering bushing is provided which incorporates a large flow check valve for fast “out-stroke” action.
- c. A socket-keyed needle valve is provided that is flush with the side of the cap when wide open. It is located on side number 2 in all mounting styles except ME5, ME6, TM1, TM2 and TM3. In these styles it is located on side number 3.



Tie Rods Extended Both Ends Mount
Style NM1

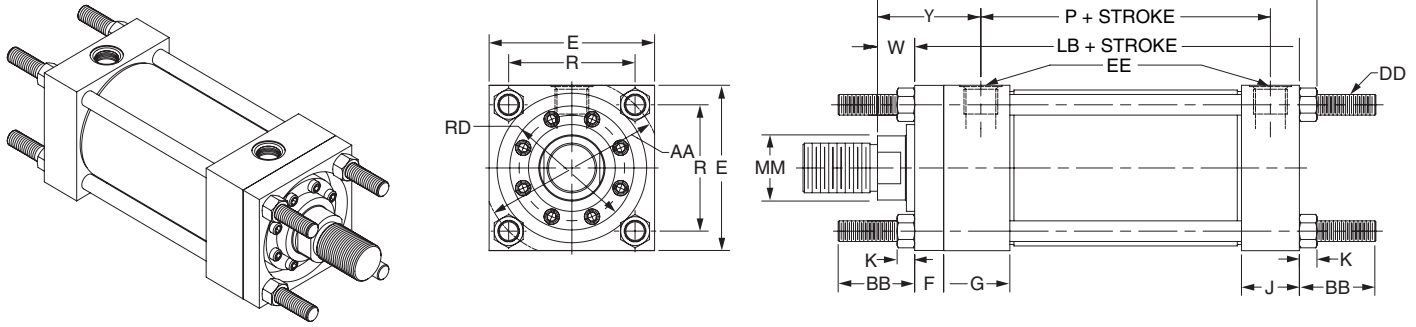

Tie Rods Extended Cap End Mount
Style NM2

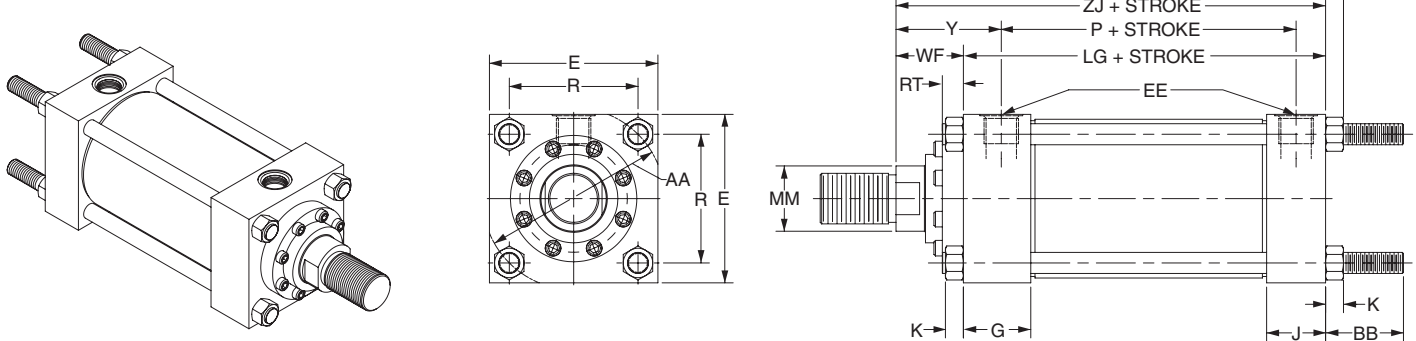

Tie Rods Extended Head End Mount
Style NM3

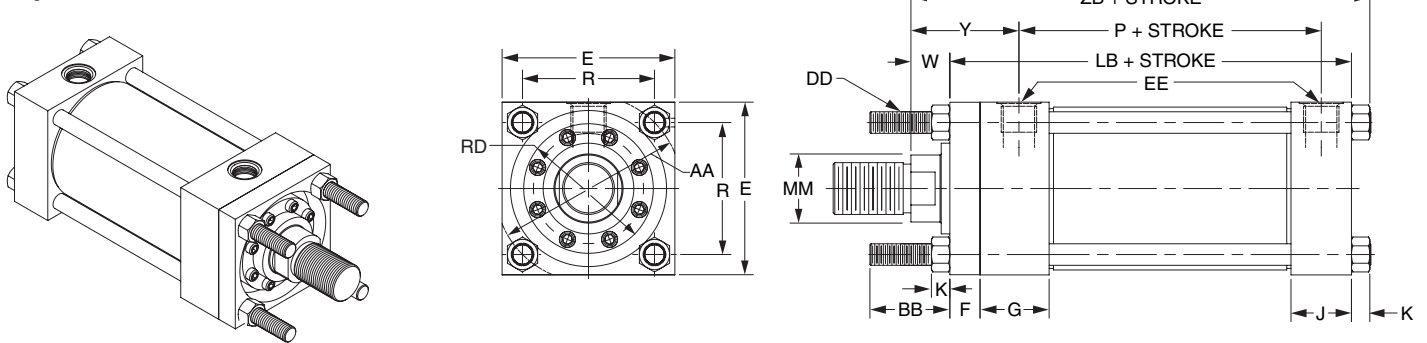

Rod End Dimensions (for Retainer Held Gland) – See Table 2

See chart on page 32 to determine which bore, rod and mount combinations have this feature.

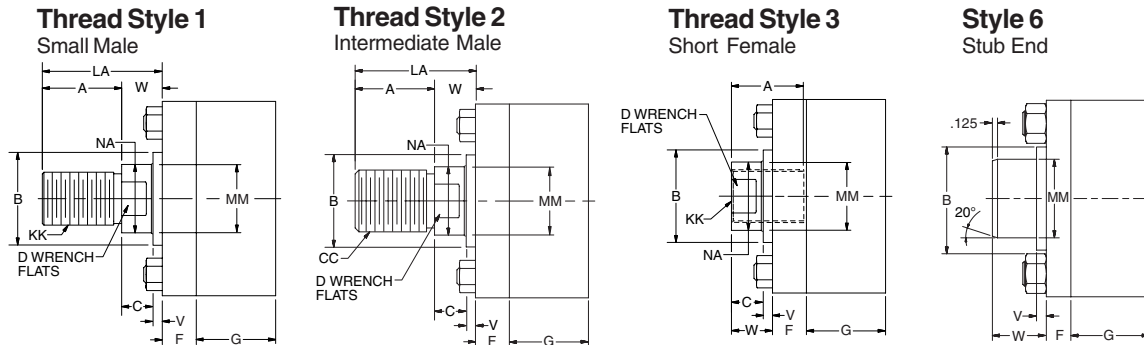

A high strength rod end stud is supplied on thread style 1 through 2" diameter rods. Larger sizes or special rod ends are cut threads. Style 1 rod ends are recommended where the workpiece is secured against the rod shoulder. When the workpiece is not shouldered,

style 1 rod ends are recommended through 2" piston rod diameters and style 2 rod ends are recommended on larger diameters. Use style 3 for applications where female rod end threads are required. If rod end is not specified, style 1 will be supplied.

"Special" Thread Style 4

Special thread, extension, rod eye, blank, etc., are also available.

To order, specify "Style 4" and give desired dimensions for KK, A and W. If otherwise special, furnish dimensioned sketch.

Table 1—Envelope and Mounting Dimensions

Bore	AA	BB	DD	E	EE		F	G	J	K	R	Add Stroke		
					NPTF \ominus	SAE*						LB	LG	P
1½	2.3	1¾	¾-24	2½	½	8	¾	1¾	1½	¾	1.63	5	4⅝	27/8
2	2.9	1⅓ ₁₆	½-20	3	½	8	⅝	1¾	1½	7/16	2.05	5¼	4⅝	27/8
2½	3.6	1⅓ ₁₆	½-20	3½	½	8	⅝	1¾	1½	7/16	2.55	5¾	4¾	3
3¼	4.6	2 ⁵ / ₁₆	⅝-18	4½	¾	12	¾	2	1¾	9/16	3.25	6¼	5½	3½
4	5.4	2 ⁵ / ₁₆	⅝-18	5	¾	12	7/8	2	1¾	9/16	3.82	6 ⁵ / ₈	5¾	3¾
5	7.0	3 ³ / ₁₆	7/8-14	6½	¾	12	7/8	2	1¾	1 ³ / ₁₆	4.95	7⅞	6¼	4¼
6	8.1	3 ⁵ / ₈	1-14	7½	1	16	1	2¼	2¼	7/8	5.73	8 ³ / ₈	7 ³ / ₈	47/8

*SAE straight thread ports are standard and are indicated by port number.
 \ominus NPTF ports are available at no extra charge.

Table 3 — Envelope and Mounting Dimensions

Table 2—Rod Dimensions

Bore	Rod Dia. MM	Thread		Rod Extensions and Pilot Dimensions														Add Stroke		
		Style 2 CC	Style 1 & 3 KK	A	+0.000 -0.002 B	C	D	LA	LAF	NA	RD (Max.)	RT	V	VF	VH	W	WF	Y	ZB	ZJ
1½	5/8	1/2-20	7/16-20	¾	1.124	¾	½	13/8	1¾	9/16	115/16	¾	¼	¼	3/16	5/8	1	2	6	55/8
	1	7/8-14	¾-16	11/8	1.499	½	7/8	21/8	2½	15/16	23/8	¾	½	½	3/16	1	13/8	23/8	63/8	6
2	1	7/8-14	¾-16	11/8	1.499	½	7/8	17/8	2½	15/16	23/8	¾	¼	½	3/16	¾	13/8	23/8	67/16	6
	13/8	11/4-12	1-14	15/8	1.999	5/8	11/8	25/8	3¼	15/16	27/8	¾	¾	5/8	3/16	1	15/8	25/8	611/16	6¼
2½	1	7/8-14	¾-16	11/8	1.499	½	7/8	—	2½	15/16	23/8	¾	¼	½	3/16	—	13/8	23/8	69/16	61/8
	13/8	11/4-12	1-14	15/8	1.999	5/8	11/8	—	3¼	15/16	27/8	¾	¾	5/8	3/16	—	15/8	25/8	613/16	63/8
	1¾	11/2-12	1¼-12	2	2.374	¾	11/2	—	37/8	111/16	315/32	5/8	½	½	3/16	—	17/8	27/8	71/16	65/8
3¼	13/8	11/4-12	1-14	15/8	1.999	5/8	11/8	—	3¼	15/16	27/8	¾	¼	5/8	3/16	—	15/8	23/4	711/16	71/8
	1¾	11/2-12	1¼-12	2	2.374	¾	11/2	—	37/8	111/16	315/32	5/8	¾	½	3/16	—	17/8	3	715/16	73/8
4	2	13/4-12	2¼-12	2¼	2.624	7/8	111/16	—	4¼	115/16	323/32	5/8	¾	½	¼	—	2	31/8	81/16	71/2
	1¾	11/2-12	1¼-12	2	2.374	¾	11/2	—	37/8	111/16	315/32	5/8	¼	½	3/16	—	17/8	3	83/16	75/8
	2	13/4-12	11/2-12	2¼	2.624	7/8	111/16	—	4¼	115/16	323/32	5/8	¼	½	¼	—	2	31/8	85/16	7¾
5	2½	2¼-12	17/8-12	3	3.124	1	21/16	—	5¼	23/8	41/4	5/8	¾	5/8	¼	—	2¼	33/8	89/16	8
	2	13/4-12	11/2-12	2¼	2.624	7/8	111/16	—	4¼	115/16	323/32	5/8	¼	½	¼	—	2	31/8	91/16	8¼
	2½	2¼-12	17/8-12	3	3.124	1	21/16	—	5¼	33/8	41/4	5/8	¾	5/8	¼	—	2¼	33/8	95/16	8½
	3	23/4-12	2¼-12	3½	3.749	1	25/8	—	5¾	27/8	57/16	7/8	¾	5/16	—	—	2¼	33/8	95/16	8½
6	3½	3¼-12	2½-12	3½	4.249	1	3	—	5¾	23/8	515/16	15/16	¾	5/16	—	—	2¼	33/8	95/16	8½
	2½	2¼-12	17/8-12	3	3.124	1	21/16	—	5¼	23/8	41/4	5/8	¼	5/8	¼	—	2¼	31/2	101/2	95/8
	3	23/4-12	2¼-12	3½	3.749	1	25/8	—	5¾	27/8	57/16	7/8	¼	5/16	—	—	2¼	31/2	101/2	95/8
	3½	3¼-12	2½-12	3½	4.249	1	3	—	5¾	33/8	515/16	15/16	¼	5/16	—	—	2¼	31/2	101/2	95/8
6	4	3¾-12	3-12	4	4.749	1	33/8	—	6¼	37/8	65/16	15/16	¼	5/16	—	—	2¼	31/2	101/2	95/8

Rod End Dimensions (for Bolted Gland) – See Table 2

See chart on page 32 to determine which bore, rod and mount combinations have this feature.

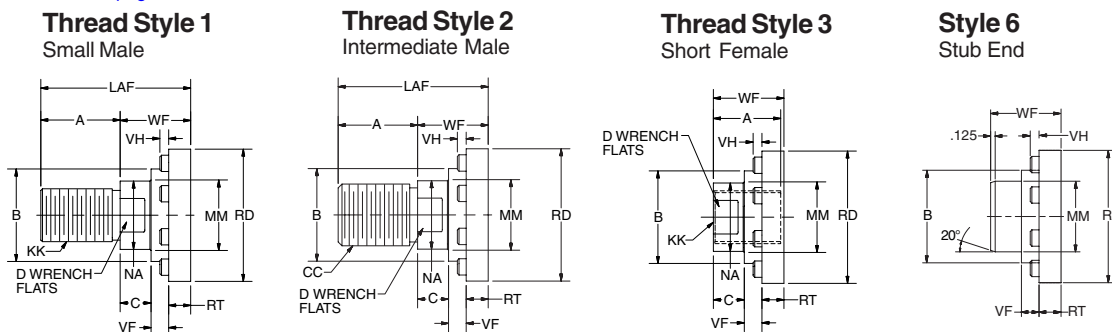

A high strength rod end stud is supplied on thread style 1 through 2" diameter rods. Larger sizes or special rod ends are cut threads. Style 1 rod ends are recommended where the workpiece is secured against the rod shoulder. When the workpiece is not shouldered,

style 1 rod ends are recommended through 2" piston rod diameters and style 2 rod ends are recommended on larger diameters. Use style 3 for applications where female rod end threads are required. If rod end is not specified, style 1 will be supplied.

"Special" Thread Style 4

Special thread, extension, rod eye, blank, etc., are also available.

To order, specify "Style 4" and give desired dimensions for KK, A and WF. If otherwise special, furnish dimensioned sketch.

**Head Rectangular
 Flange Mount
 Style REF2**

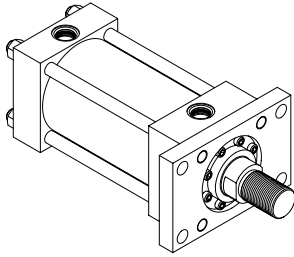

Maximum Pressure Rating - PSI
 Push Application

Bore	Rod Dia				
	5/8	1	1 3/8	1 3/4	2
1 1/2	1400	1000	-	-	-
2	-	2000	1200	-	-
2 1/2	-	700	700	1000	-
3 1/4	-	-	800	800	600
4	-	-	-	1000	1000
5	-	-	-	-	850
Bore	Rod Dia				
	2 1/2	3	3 1/2	4	5
4	700	-	-	-	-
5	850	450	800	-	-
6	650	650	400	400	-

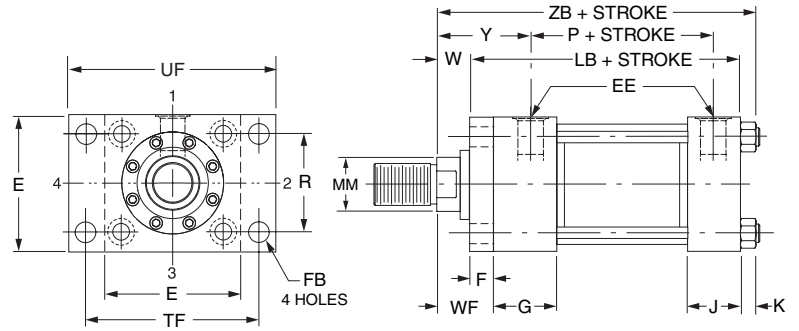

**Head Square
 Flange Mount
 Style REF1**

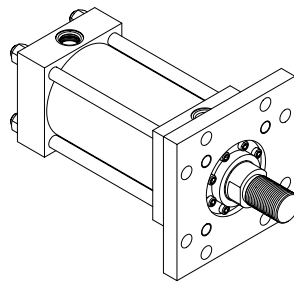

Maximum Pressure Rating - PSI
 Push Application

Bore	Rod Dia				
	5/8	1	1 3/8	1 3/4	2
1 1/2	3000	3000	-	-	-
2	-	3000	3000	-	-
2 1/2	-	3000	3000	3000	-
3 1/4	-	-	3000	3000	3000
4	-	-	-	3000	3000
5	-	-	-	-	2500
Bore	Rod Dia				
	2 1/2	3	3 1/2	4	5
4	3000	-	-	-	-
5	2500	1800	2300	-	-
6	2000	2000	1600	1600	-

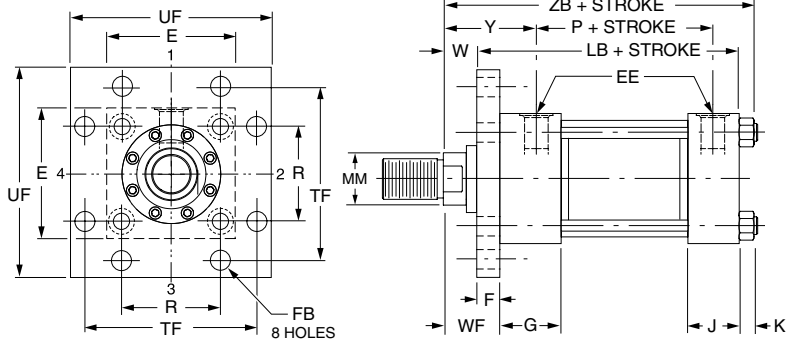

**Head Rectangular Mount
 Style ME5**

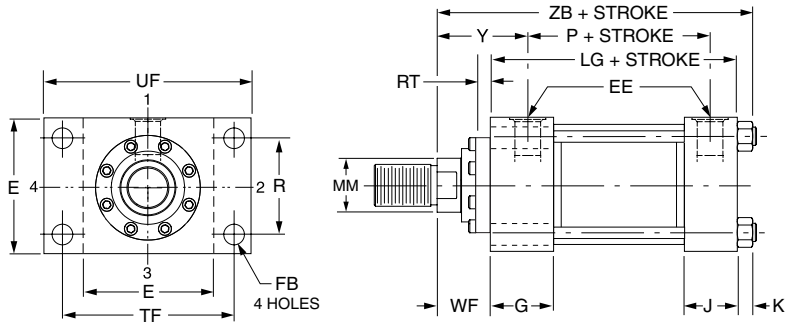
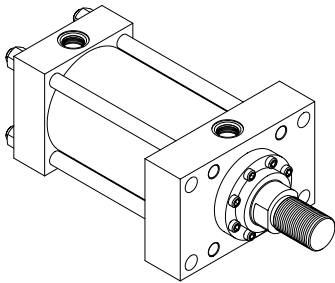

Rod End Dimensions (for Retainer Held Gland) – See Table 2

See chart on page 32 to determine which bore, rod and mount combinations have this feature.

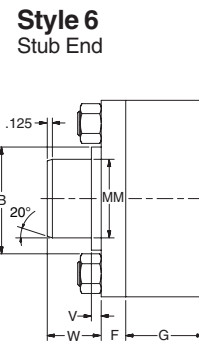
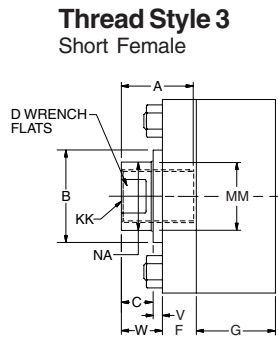
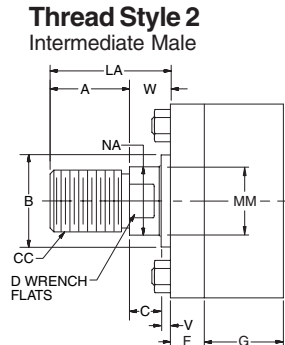
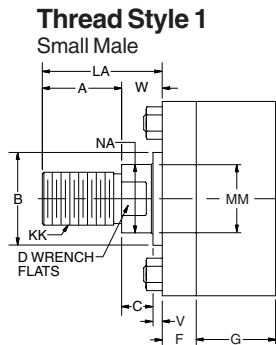

“Special” Thread Style 4

Special thread, extension, rod eye, blank, etc., are also available.

To order, specify “Style 4” and give desired dimensions for KK, A and W. If otherwise special, furnish dimensioned sketch.

A high strength rod end stud is supplied on thread style 1 through 2" diameter rods. Larger sizes or special rod ends are cut threads. Style 1 rod ends are recommended where the workpiece is secured against the rod shoulder. When the workpiece is not shouldered,

style 1 rod ends are recommended through 2" piston rod diameters and style 2 rod ends are recommended on larger diameters. Use style 3 for applications where female rod end threads are required. If rod end is not specified, style 1 will be supplied.

Table 1—Envelope and Mounting Dimensions

Bore	E	EE		F	FB	G	J	K	R	TF	UF	Add Stroke		
		NPTF [⊖]	SAE★									LB	LG	P
1½	2½	½	8	¾	7/16	1¾	1½	¾	1.63	37/16	4¼	5	45/8	27/8
2	3	½	8	5/8	9/16	1¾	1½	7/16	2.05	4½	5½	5¼	45/8	27/8
2½	3½	½	8	5/8	9/16	1¾	1½	7/16	2.55	45/8	55/8	53/8	43/4	3
3¼	4½	¾	12	¾	11/16	2	1¾	9/16	3.25	57/8	7½	6¼	5½	3½
4	5	¾	12	7/8	11/16	2	1¾	9/16	3.82	63/8	75/8	65/8	5¾	3¾
5	6½	¾	12	7/8	15/16	2	1¾	13/16	4.95	83/16	9¾	7½	6¼	4¼
6	7½	1	16	1	11/16	2¼	2¼	7/8	5.73	97/16	11¼	83/8	73/8	47/8

★ SAE straight thread ports are standard and are indicated by port number.
 ⊖ NPTF ports are available at no extra charge.

Table 3—Envelope and Mounting Dimensions

Table 2—Rod Dimensions

Bore	Rod Dia. MM	Thread		Rod Extensions and Pilot Dimensions														Y	Add Stroke ZB
		Style 2 CC	Style 1 & 3 KK	A	+0.000 -0.002 B	C	D	LA	LAF	NA	RD (Max.)	RT	V	VF	VH	W	WF		
1½	5/8	1½-20	7/16-20	¾	1.124	3/8	½	13/8	1¾	9/16	115/16	3/8	¼	¼	3/16	5/8	1	2	6
	1	7/8-14	¾-16	11/8	1.499	½	7/8	2½	2½	15/16	23/8	3/8	½	½	3/16	1	13/8	23/8	63/8
2	1	7/8-14	¾-16	11/8	1.499	½	7/8	17/8	2½	15/16	23/8	3/8	¼	½	3/16	¾	13/8	23/8	67/16
	13/8	1¼-12	1-14	15/8	1.999	5/8	1½	25/8	3¼	15/16	27/8	3/8	3/8	5/8	3/16	1	15/8	25/8	611/16
2½	1	7/8-14	¾-16	11/8	1.499	½	7/8	17/8	2½	15/16	23/8	3/8	¼	½	3/16	¾	13/8	23/8	69/16
	13/8	1¼-12	1-14	15/8	1.999	5/8	1½	25/8	3¼	15/16	27/8	3/8	3/8	5/8	3/16	1	15/8	25/8	613/16
3¼	13/8	1¼-12	1-14	15/8	1.999	5/8	1½	2½	3¼	15/16	27/8	3/8	¼	5/8	3/16	7/8	15/8	23/4	711/16
	1¾	1½-12	1¼-12	2	2.374	¾	1½	3¼	37/8	11/16	315/32	5/8	½	½	3/16	11/4	17/8	27/8	71/16
4	13/8	1¼-12	1-14	15/8	1.999	5/8	1½	2½	3¼	15/16	27/8	3/8	¼	5/8	3/16	7/8	15/8	23/4	711/16
	1¾	1½-12	1¼-12	2	2.374	¾	1½	3¼	37/8	11/16	315/32	5/8	3/8	½	3/16	11/8	17/8	3	715/16
5	2	13/4-12	1½-12	2¼	2.624	7/8	11/16	3½	4¼	115/16	323/32	5/8	3/8	½	¼	11/4	2	3½	81/16
	13/4	1½-12	1¼-12	2	2.374	¾	1½	3	37/8	11/16	315/32	5/8	¼	½	3/16	1	17/8	3	83/16
6	2	13/4-12	1½-12	2¼	2.624	7/8	11/16	33/8	4¼	115/16	323/32	5/8	¼	½	¼	11/8	2	3½	85/16
	2½	2¼-12	17/8-12	3	3.124	1	21/16	43/8	5¼	23/8	4¼	5/8	3/8	5/8	¼	13/8	2¼	33/8	89/16
7	2	13/4-12	1½-12	2¼	2.624	7/8	11/16	33/8	4¼	115/16	323/32	5/8	¼	½	¼	11/8	2	3½	91/16
	2½	2¼-12	17/8-12	3	3.124	1	21/16	43/8	5¼	23/8	4¼	5/8	3/8	5/8	¼	13/8	2¼	33/8	95/16
8	3	23/4-12	2¼-12	3½	3.749	1	25/8	47/8	53/4	27/8	57/16	7/8	3/8	5/16	—	13/8	2¼	33/8	95/16
	3½	3¼-12	2½-12	3½	4.249	1	3	47/8	53/4	33/8	515/16	15/16	3/8	5/16	—	13/8	2¼	33/8	95/16
9	2½	2¼-12	17/8-12	3	3.124	1	21/16	4¼	5¼	23/8	4¼	5/8	¼	5/8	¼	11/4	2¼	3½	101/2
	3	23/4-12	2¼-12	3½	3.749	1	25/8	43/4	53/4	27/8	57/16	7/8	¼	5/16	—	11/4	2¼	3½	101/2
10	3½	3¼-12	2½-12	3½	4.249	1	3	43/4	53/4	33/8	515/16	15/16	¼	5/16	—	11/4	2¼	3½	101/2
	4	33/4-12	3-12	4	4.749	1	33/8	5¼	6¼	37/8	65/16	15/16	¼	5/16	—	11/4	2¼	3½	101/2

Rod End Dimensions (for Bolted Gland) – See Table 2

See chart on page 32 to determine which bore, rod and mount combinations have this feature.

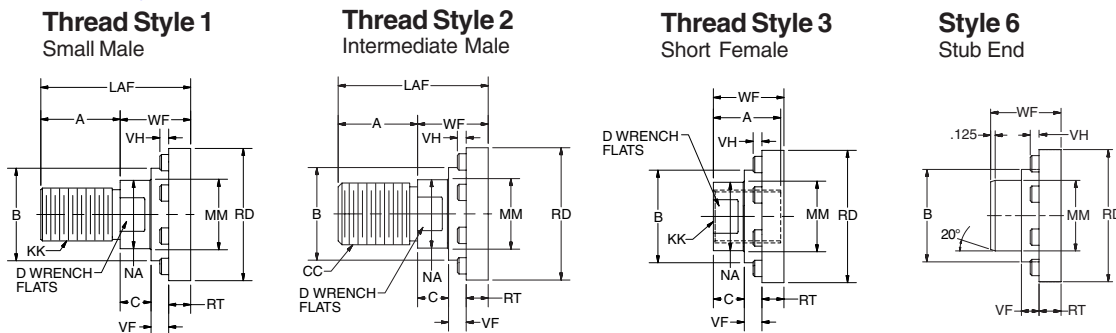

A high strength rod end stud is supplied on thread style 1 through 2" diameter rods. Larger sizes or special rod ends are cut threads. Style 1 rod ends are recommended where the workpiece is secured against the rod shoulder. When the workpiece is not shouldered,

style 1 rod ends are recommended through 2" piston rod diameters and style 2 rod ends are recommended on larger diameters. Use style 3 for applications where female rod end threads are required. If rod end is not specified, style 1 will be supplied.

"Special" Thread Style 4

Special thread, extension, rod eye, blank, etc., are also available.

To order, specify "Style 4" and give desired dimensions for KK, A and WF. If otherwise special, furnish dimensioned sketch.

Cap Rectangular Flange Mount Style BEF2

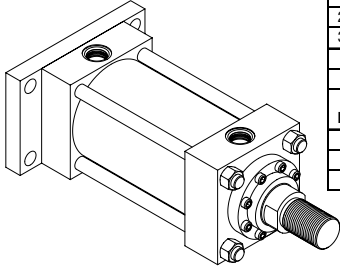

Maximum Pressure Rating - PSI
 Pull Application

Bore	Rod Dia				
	5/8	1	1 3/8	1 3/4	2
1 1/2	2500	3000	-	-	-
2	-	3000	3000	-	-
2 1/2	-	3000	3000	3000	-
3 1/4	-	-	3000	3000	3000
4	-	-	-	3000	3000
5	-	-	-	-	2000

Bore	Rod Dia				
	2 1/2	3	3 1/2	4	5
4	3000	-	-	-	-
5	2000	2500	3000	-	-
6	1800	2000	2000	2500	-

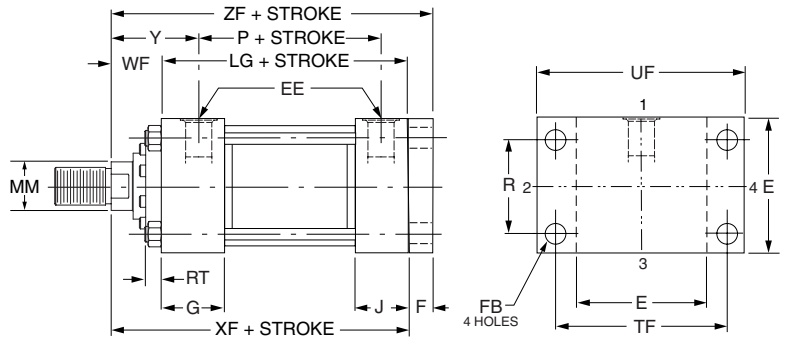

Cap Square Flange Mount Style BEF1

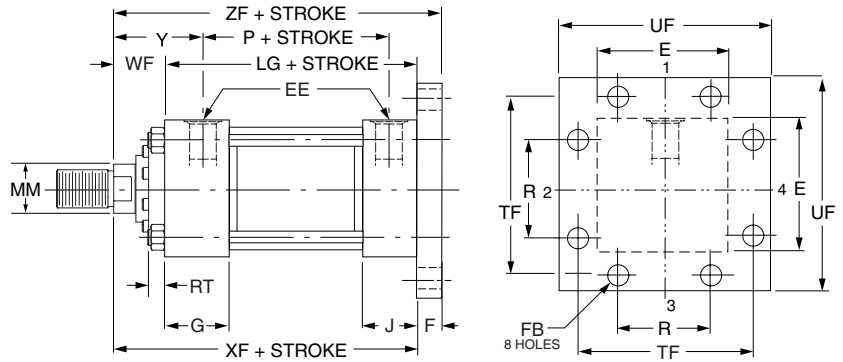
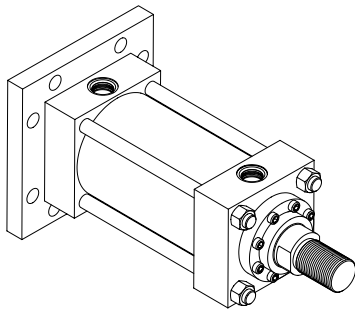

Cap Rectangular Mount Style ME6

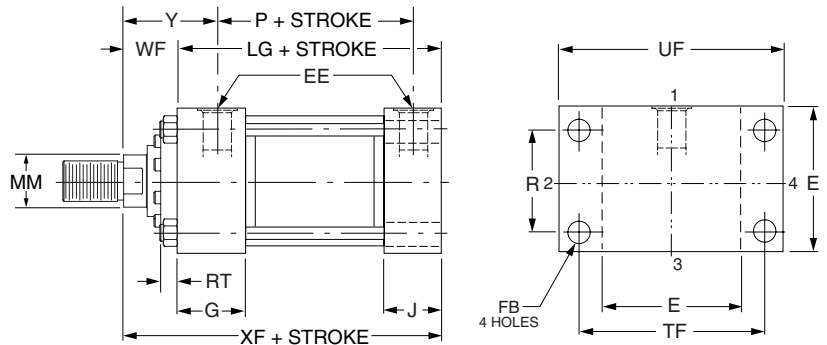
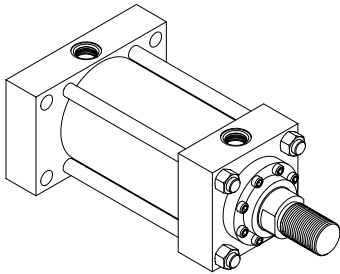

Rod End Dimensions (for Retainer Held Gland) – See Table 2

See chart on page 32 to determine which bore, rod and mount combinations have this feature.

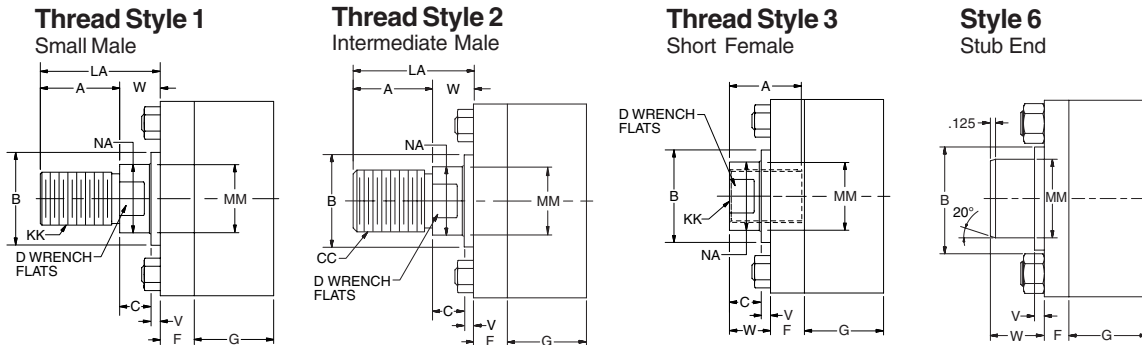

“Special” Thread Style 4

Special thread, extension, rod eye, blank, etc., are also available.

To order, specify “Style 4” and give desired dimensions for KK, A and W. If otherwise special, furnish dimensioned sketch.

A high strength rod end stud is supplied on thread style 1 through 2" diameter rods. Larger sizes or special rod ends are cut threads. Style 1 rod ends are recommended where the workpiece is secured against the rod shoulder. When the workpiece is not shouldered,

style 1 rod ends are recommended through 2" piston rod diameters and style 2 rod ends are recommended on larger diameters. Use style 3 for applications where female rod end threads are required. If rod end is not specified, style 1 will be supplied.

Table 1—Envelope and Mounting Dimensions

Bore	E	EE		F	FB	G	J	K	R	TF	UF	Add Stroke	
		NPTF⊕	SAE★									LG	P
1½	2½	½	8	¾	7/16	1¾	1½	¾	1.63	37/16	4¼	45/8	27/8
2	3	½	8	5/8	9/16	1¾	1½	7/16	2.05	4½	5½	45/8	27/8
2½	3½	½	8	5/8	9/16	1¾	1½	7/16	2.55	45/8	55/8	43/4	3
3¼	4½	¾	12	¾	11/16	2	1¾	9/16	3.25	57/8	7½	5½	3½
4	5	¾	12	7/8	11/16	2	1¾	9/16	3.82	63/8	75/8	5¾	3¾
5	6½	¾	12	7/8	15/16	2	1¾	13/16	4.95	83/16	9¾	6¼	4¼
6	7½	1	16	1	1¼	2¼	2¼	7/8	5.73	97/16	11¼	73/8	47/8

★ SAE straight thread ports are standard and are indicated by port number.
 ⊕ NPTF ports are available at no extra charge.

Table 3—Envelope and Mounting Dimensions

Table 2—Rod Dimensions

Bore	Rod Dia. MM	Thread		Rod Extensions and Pilot Dimensions														Add Stroke		
		Style 2 CC	Style 1 & 3 KK	A	+0.000 -0.002 B	C	D	LA	LAF	NA	RD (Max.)	RT	V	VF	VH	W	WF	Y	XF	ZF
1½	5/8	½-20	7/16-20	¾	1.124	¾	½	—	1¾	9/16	115/16	3/8	¼	¼	3/16	—	1	2	55/8	6
	1	7/8-14	¾-116	11/8	1.499	½	7/8	2½	15/16	23/8	3/8	½	½	3/16	1	13/8	23/8	6	63/8	
2	1	7/8-14	¾-16	11/8	1.499	½	7/8	—	2½	15/16	23/8	3/8	¼	½	3/16	—	13/8	23/8	6	65/8
	13/8	11/4-12	1-14	15/8	1.999	5/8	11/8	25/8	3¼	15/16	27/8	3/8	3/8	5/8	3/16	1	15/8	25/8	6¼	67/8
2½	1	7/8-14	¾-16	11/8	1.499	½	7/8	—	2½	15/16	23/8	3/8	¼	½	3/16	—	13/8	23/8	6½	6¾
	13/8	11/4-12	1-14	15/8	1.999	5/8	11/8	—	3¼	15/16	27/8	3/8	3/8	5/8	3/16	—	15/8	25/8	63/8	7
	13/4	11/2-12	1¼-12	2	2.374	¾	1½	—	37/8	11/16	315/32	5/8	½	½	3/16	—	17/8	27/8	65/8	7¼
3¼	13/8	11/4-12	1-14	15/8	1.999	5/8	11/8	—	3¼	15/16	27/8	3/8	¼	5/8	3/16	—	15/8	23/4	7½	77/8
	13/4	11/2-12	1¼-12	2	2.374	¾	1½	—	37/8	11/16	315/32	5/8	3/8	½	3/16	—	17/8	3	73/8	8½
	2	13/4-12	1½-12	2¼	2.624	7/8	11/16	—	4¼	115/16	323/32	5/8	3/8	½	¼	—	2	3½	7½	8¼
4	13/4	11/2-12	1¼-12	2	2.374	¾	1½	—	37/8	11/16	315/32	5/8	¼	½	3/16	—	17/8	3	75/8	8½
	2	13/4-12	1½-12	2¼	2.624	7/8	11/16	—	4¼	115/16	323/32	5/8	¼	½	¼	—	2	3½	7¾	85/8
	2½	2¼-12	17/8-12	3	3.124	1	21/16	—	5¼	23/8	4¼	5/8	3/8	5/8	¼	—	2¼	33/8	8	87/8
5	2	13/4-12	1½-12	2¼	2.624	7/8	11/16	—	4¼	115/16	323/32	5/8	¼	½	¼	—	2	3½	8¼	9½
	2½	2¼-12	17/8-12	3	3.124	1	21/16	—	5¼	23/8	4¼	5/8	3/8	5/8	¼	—	2¼	33/8	8½	93/8
	3	23/4-12	2¼-12	3½	3.749	1	25/8	—	5¾	27/8	57/16	7/8	3/8	5/16	—	—	2¼	33/8	8½	93/8
	3½	3¼-12	2½-12	3½	4.249	1	3	—	5¾	33/8	515/16	15/16	3/8	5/16	—	—	2¼	33/8	8½	93/8
6	2½	2¼-12	17/8-12	3	3.124	1	21/16	—	5¼	23/8	4¼	5/8	¼	5/8	¼	—	2¼	3½	95/8	105/8
	3	23/4-12	2¼-12	3½	3.749	1	25/8	—	5¾	27/8	57/16	7/8	¼	5/16	—	—	2¼	3½	95/8	105/8
	3½	3¼-12	2½-12	3½	4.249	1	3	—	5¾	33/8	515/16	15/16	¼	5/16	—	—	2¼	3½	95/8	105/8
	4	3¾-12	3-12	4	4.749	1	33/8	—	6¼	37/8	65/16	15/16	¼	5/16	—	—	2¼	3½	95/8	105/8

Rod End Dimensions (for Bolted Gland) – See Table 2

See chart on page 32 to determine which bore, rod and mount combinations have this feature.

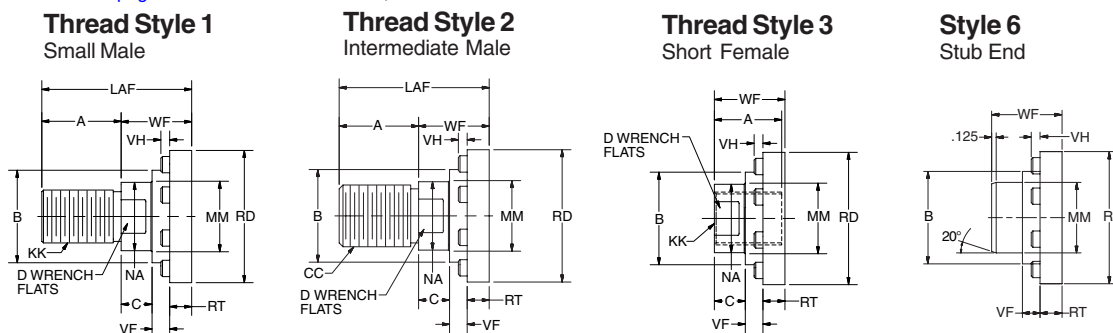

A high strength rod end stud is supplied on thread style 1 through 2" diameter rods. Larger sizes or special rod ends are cut threads. Style 1 rod ends are recommended where the workpiece is secured against the rod shoulder. When the workpiece is not shouldered,

style 1 rod ends are recommended through 2" piston rod diameters and style 2 rod ends are recommended on larger diameters. Use style 3 for applications where female rod end threads are required. If rod end is not specified, style 1 will be supplied.

"Special" Thread Style 4

Special thread, extension, rod eye, blank, etc., are also available.

To order, specify "Style 4" and give desired dimensions for KK, A and WF. If otherwise special, furnish dimensioned sketch.

Side Lug Mount
Style SL

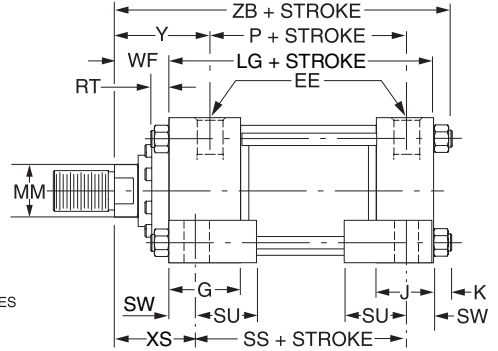
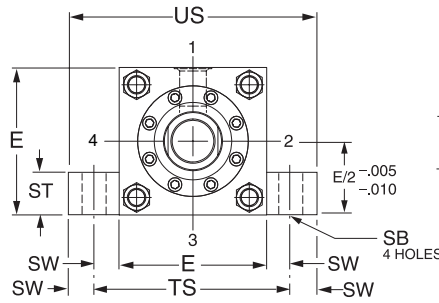
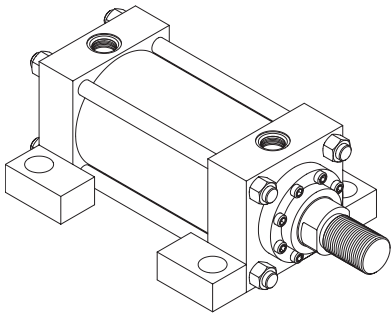

Style SL cylinders have mounting lugs welded to the head and cap, and are considered to be a fixed mount that does not absorb force on its centerline. The plane of the mounting surface is not through the centerline of the cylinder, and for this reason **Style SL** cylinders produce a turning moment as the cylinder applies force to the load. This turning moment tends to rotate the cylinder about its mounting

bolts. If the cylinder is not well secured to the machine member on which it is mounted or the load is not well-guided, this turning moment results in side load applied to rod gland and piston bearings. **To avoid this problem, Style SL cylinders should be specified with a stroke length at least equal to the bore size.**

Side Tap Mount
Style FS

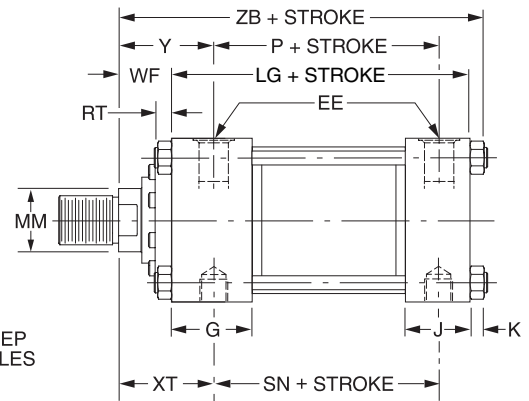
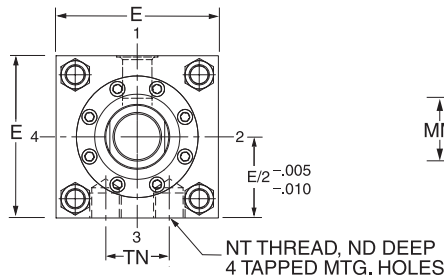
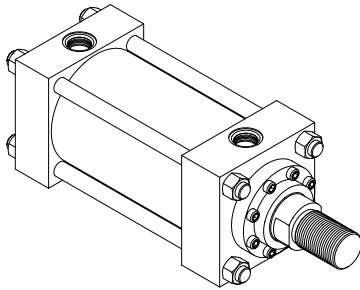

Style FS cylinders have side tapped holes for flush mounting, and are considered to be a fixed mount that does not absorb force on its centerline. The plane of the mounting surface is not through the centerline of the cylinder, and for this reason **Style FS** cylinders produce a turning moment as the cylinder applies force to the load. This turning moment tends to rotate the cylinder about its mounting

bolts. If the cylinder is not well secured to the machine member on which it is mounted or the load is not well-guided, this turning moment results in side load applied to rod gland and piston bearings. **To avoid this problem, Style FS cylinders should be specified with a stroke length at least equal to the bore size.**

Rod End Dimensions (for Retainer Held Gland) – See Table 2

See chart on page 32 to determine which bore, rod and mount combinations have this feature.

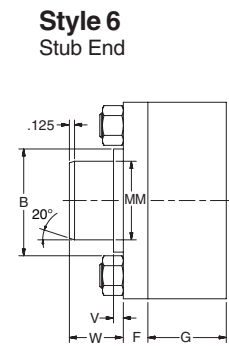
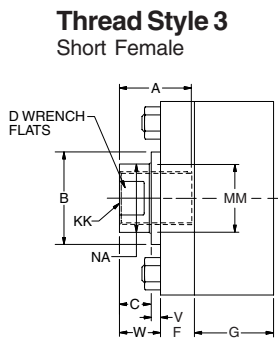
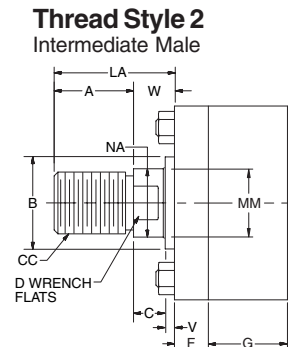
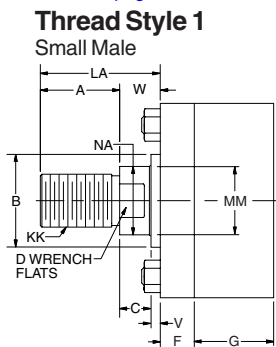

“Special” Thread Style 4

Special thread, extension, rod eye, blank, etc., are also available. To order, specify “Style 4” and give desired dimensions for KK, A and W. If otherwise special, furnish dimensioned sketch.

A high strength rod end stud is supplied on thread style 1 through 2” diameter rods. Larger sizes or special rod ends are cut threads. Style 1 rod ends are recommended where the workpiece is secured against the rod shoulder. When the workpiece is not shouldered,

style 1 rod ends are recommended through 2” piston rod diameters and style 2 rod ends are recommended on larger diameters. Use style 3 for applications where female rod end threads are required. If rod end is not specified, style 1 will be supplied.

Table 1—Envelope and Mounting Dimensions

Bore	E	EE		F	G	J	K	L	NT	R	SB	ST	SU	SW	TN	TS	US	Add Stroke			
		NPTF⊖	SAE★															LG	P	SN	SS
1½	2½	½	8	¾	1¾	1½	¾	¾	¾-16	1.63	7/16	½	15/16	¾	¾	3¼	4	45/8	27/8	27/8	37/8
2	3	½	8	5/8	1¾	1½	7/16	1¼	½-13	2.05	9/16	¾	1¼	½	15/16	4	5	45/8	27/8	27/8	35/8
2½	3½	½	8	5/8	1¾	1½	7/16	1¼	5/8-11	2.55	13/16	1	19/16	11/16	15/16	47/8	6¼	4¾	3	3	33/8
3¼	4½	¾	12	¾	2	1¾	9/16	1½	¾-10	3.25	13/16	1	19/16	11/16	1½	57/8	7¼	5½	3½	3½	4½
4	5	¾	12	7/8	2	1¾	9/16	2½	1-8	3.82	1½	1¼	2	7/8	2½	6¾	8½	5¾	3¾	3¾	4
5	6½	¾	12	7/8	2	1¾	13/16	2¼	1-8	4.95	1½	1¼	2	7/8	2½	8¼	10	6¼	4¼	4¼	4½
6	7½	1	16	1	2¼	2¼	7/8	2½	1¼-7	5.73	15/16	1½	2½	1½	35/16	9¾	12	7¾	47/8	5½	5½

★ SAE straight thread ports are standard and are indicated by port number.
 ⊖ NPTF ports are available at no extra charge.

Table 2—Rod Dimensions

Bore	Rod Dia. MM	Thread		Rod Extensions and Pilot Dimensions																Add Stroke			
		Style 2 CC	Style 1 & 3 KK	A	+000 -002 B	C	D	LA	LAF	NA	RD (Max.)	RT	V	VF	VH	W	WF	ND	XS	XT	Y	ZB	
1½	5/8	1/2-20	7/16-20	¾	1.124	¾	1/2	—	1¾	9/16	115/16	¾	¼	¼	3/16	—	1	¾	13/8	2	2	6	
	1	7/8-14	¾-16	11/8	1.499	½	7/8	2½	2½	15/16	23/8	¾	½	½	3/16	1	13/8	¾	1¾	23/8	23/8	63/8	
2	1	7/8-14	¾-16	11/8	1.499	½	7/8	—	2½	15/16	23/8	¾	¼	½	3/16	—	13/8	7/16	17/8	23/8	23/8	67/16	
	13/8	1¼-12	1-14	15/8	1.999	5/8	11/8	25/8	3¼	15/16	27/8	¾	¾	5/8	3/16	1	15/8	7/16	2½	25/8	25/8	611/16	
2½	1	7/8-14	¾-16	11/8	1.499	½	7/8	—	2½	15/16	23/8	¾	¼	½	3/16	—	13/8	½	21/16	23/8	23/8	69/16	
	13/8	1¼-12	1-14	15/8	1.999	5/8	11/8	—	3¼	15/16	27/8	¾	¾	5/8	3/16	—	15/8	½	25/16	25/8	25/8	613/16	
3¼	13/8	1¼-12	1-14	15/8	1.999	5/8	11/8	—	3¼	15/16	27/8	¾	¼	5/8	3/16	—	15/8	11/16	25/16	2¾	2¾	711/16	
	13/4	1½-12	1¼-12	2	2.374	¾	1½	—	37/8	111/16	315/32	5/8	½	½	3/16	—	17/8	½	29/16	27/8	27/8	71/16	
4	13/8	1¼-12	1-14	15/8	1.999	5/8	11/8	—	3¼	15/16	27/8	¾	¼	5/8	3/16	—	15/8	11/16	25/16	2¾	2¾	711/16	
	13/4	1½-12	1¼-12	2	2.374	¾	1½	—	37/8	111/16	315/32	5/8	¾	½	3/16	—	17/8	11/16	29/16	3	3	715/16	
5	2	13/4-12	1½-12	2¼	2.624	7/8	111/16	—	4¼	115/16	323/32	5/8	¾	½	¼	—	2	11/16	211/16	3½	3½	81/16	
	2½	1½-12	1¼-12	2	2.374	¾	1½	—	37/8	111/16	315/32	5/8	¼	½	3/16	—	17/8	11/16	2¾	3	3	83/16	
6	2	13/4-12	1½-12	2¼	2.624	7/8	111/16	—	4¼	115/16	323/32	5/8	¼	½	¼	—	2	11/16	27/8	3½	3½	85/16	
	2½	2¼-12	17/8-12	3	3.124	1	21/16	—	5¼	23/8	4¼	5/8	¾	5/8	¼	—	2¼	11/16	2½	33/8	33/8	89/16	
7	2	13/4-12	1½-12	2¼	2.624	7/8	111/16	—	4¼	115/16	323/32	5/8	¼	½	¼	—	2	1	27/8	3½	3½	91/16	
	2½	2¼-12	17/8-12	3	3.124	1	21/16	—	5¼	33/8	4¼	5/8	¾	5/8	¼	—	2¼	1	3½	33/8	33/8	95/16	
8	3	23/4-12	2¼-12	3½	3.749	1	25/8	—	5¾	27/8	57/16	7/8	¾	5/16	—	—	2¼	1	3½	33/8	33/8	95/16	
	3½	3¼-12	2½-12	3½	4.249	1	3	—	5¾	23/8	515/16	15/16	¾	5/16	—	—	2¼	1	3½	33/8	33/8	95/16	
9	2½	2¼-12	17/8-12	3	3.124	1	21/16	—	5¼	23/8	4¼	5/8	¼	5/8	¼	—	2¼	11/4	33/8	3½	3½	10½	
	3	23/4-12	2¼-12	3½	3.749	1	25/8	—	5¾	27/8	57/16	7/8	¼	5/16	—	—	2¼	11/4	33/8	3½	3½	10½	
10	3½	3¼-12	2½-12	3½	4.249	1	3	—	5¾	33/8	515/16	15/16	¼	5/16	—	—	2¼	11/4	33/8	3½	3½	10½	
	4	33/4-12	3-12	4	4.749	1	33/8	—	6¼	37/8	65/16	15/16	¼	5/16	—	—	2¼	11/4	33/8	3½	3½	10½	

Rod End Dimensions (for Bolted Gland) – See Table 2

See chart on page 32 to determine which bore, rod and mount combinations have this feature.

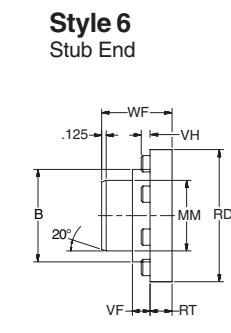
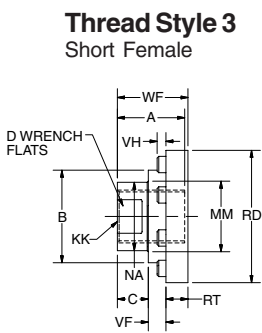
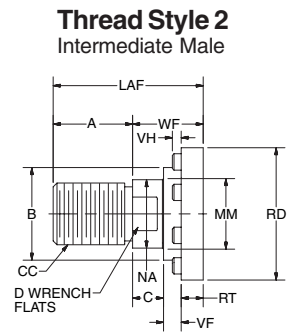
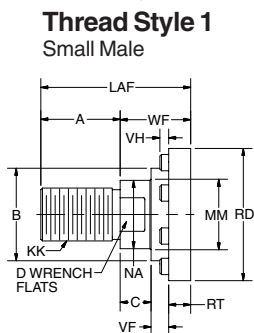

“Special” Thread Style 4

Special thread, extension, rod eye, blank, etc., are also available.

To order, specify “Style 4” and give desired dimensions for KK, A and WF. If otherwise special, furnish dimensioned sketch.

A high strength rod end stud is supplied on thread style 1 through 2” diameter rods. Larger sizes or special rod ends are cut threads. Style 1 rod ends are recommended where the workpiece is secured against the rod shoulder. When the workpiece is not shouldered,

style 1 rod ends are recommended through 2” piston rod diameters and style 2 rod ends are recommended on larger diameters. Use style 3 for applications where female rod end threads are required. If rod end is not specified, style 1 will be supplied.

Cap Fixed Clevis Mount
Style PB2

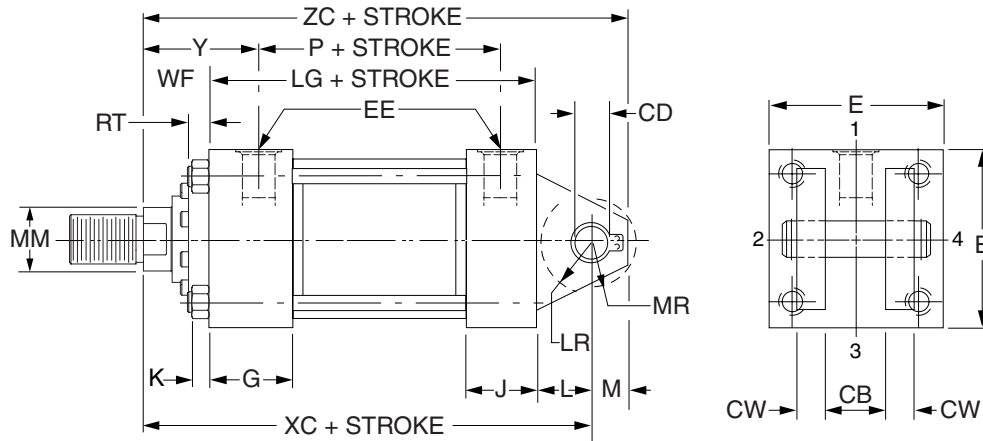
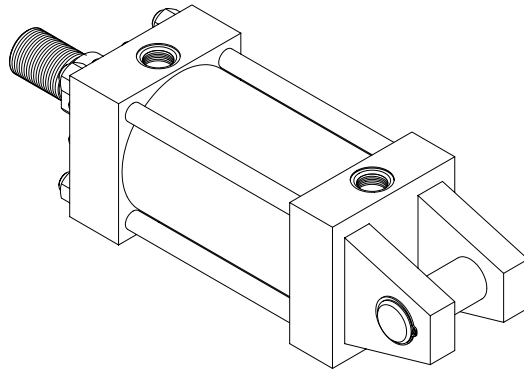

Rod End Dimensions (for Retainer Held Gland) – See Table 2

See chart on page 32 to determine which bore, rod and mount combinations have this feature.

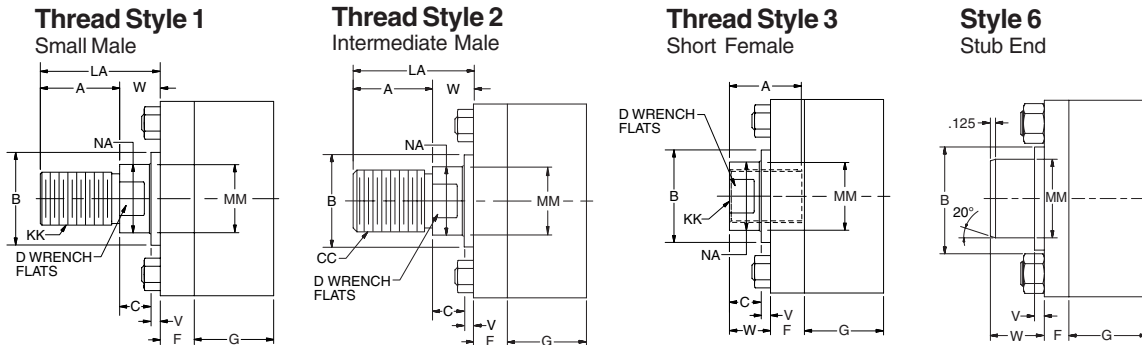

“Special” Thread Style 4

Special thread, extension, rod eye, blank, etc., are also available.

To order, specify “Style 4” and give desired dimensions for KK, A and W. If otherwise special, furnish dimensioned sketch.

A high strength rod end stud is supplied on thread style 1 through 2” diameter rods. Larger sizes or special rod ends are cut threads. Style 1 rod ends are recommended where the workpiece is secured against the rod shoulder. When the workpiece is not shouldered,

style 1 rod ends are recommended through 2” piston rod diameters and style 2 rod ends are recommended on larger diameters. Use style 3 for applications where female rod end threads are required. If rod end is not specified, style 1 will be supplied.

Table 1—Envelope and Mounting Dimensions

Bore	CB	+0.000 -0.002 CD†	CW	E	EE		F	G	J	K	L	LR	M	MR	Add Stroke	
					NPTF⊖	SAE★									LG	P
1½	¾	.501	1½	2½	½	8	¾	1¾	1½	¾	¾	9/16	½	5/8	4½/8	27/8
2	1¼	.751	5/8	3	½	8	5/8	1¾	1½	7/16	1¼	1	¾	15/16	45/8	27/8
2½	1¼	.751	5/8	3½	½	8	5/8	1¾	1½	7/16	1¼	15/16	¾	15/16	4¾	3
3¼	1½	1.001	¾	4½	¾	12	¾	2	1¾	9/16	1½	1¼	1	1¾	5½	3½
4	2	1.376	1	5	¾	12	7/8	2	1¾	9/16	2½	1¾	1¾	15/8	5¾	3¾
5	2½	1.751	1¼	6½	¾	12	7/8	2	1¾	13/16	2¼	2½	1¾	2½	6¼	4¼
6	2½	2.001	1¼	7½	1	16	1	2¼	2¼	7/8	2½	25/16	2	2¾	7¾	47/8

★ SAE straight thread ports are standard and are indicated by port number.
 ⊖ NPTF ports are available at no extra charge. †Dimension CD is pin diameter.

Table 2—Rod Dimensions

Bore	Rod Dia. MM	Thread		Rod Extensions and Pilot Dimensions															Add Stroke		
		Style 2 CC	Style 1 & 3 KK	A	+0.000 -0.002 B	C	D	LA	LAF	NA	RD (Max.)	RT	V	VF	VH	W	WF	Y	XC	ZC	
1½	5/8	1/2-20	7/16-20	¾	1.124	¾	1/2	—	1¾	9/16	115/16	¾	1/4	1/4	3/16	—	1	2	6¾/8	67/8	
	1	7/8-14	¾-16	1½	1.499	1/2	7/8	2½	2½	15/16	2¾	¾	1/2	1/2	3/16	1	1¾	2¾	6¾/4	7¼	
2	1	7/8-14	¾-16	1½	1.499	1/2	7/8	—	2½	15/16	2¾	¾	1/4	1/2	3/16	—	1¾	2¾	7¼	8	
	1¾	1¼-12	1-14	15/8	1.999	5/8	1½	25/8	3¼	15/16	27/8	¾	¾	5/8	3/16	1	15/8	25/8	7½	8¼	
2½	1	7/8-14	¾-16	1½	1.499	1/2	7/8	—	2½	15/16	2¾	¾	1/4	1/2	3/16	—	1¾	2¾	7¾	8½	
	1¾	1¼-12	1¼-12	2	2.374	¾	1½	—	37/8	111/16	315/32	5/8	1/2	1/2	3/16	—	17/8	27/8	77/8	85/8	
3¼	1¾	1¼-12	1-14	15/8	1.999	5/8	1½	—	3¼	15/16	27/8	¾	1/4	5/8	3/16	—	15/8	2¾	85/8	95/8	
	2	1¾-12	1½-12	2	2.374	¾	1½	—	37/8	111/16	315/32	5/8	¾	1/2	3/16	—	17/8	3	87/8	97/8	
4	1¾	1¼-12	1¼-12	2	2.374	¾	1½	—	37/8	111/16	315/32	5/8	1/4	1/2	3/16	—	17/8	3	9¾	11½	
	2	1¾-12	1½-12	2¼	2.624	7/8	111/16	—	4¼	15/16	323/32	5/8	1/4	1/2	1/4	—	2	3½	97/8	11¼	
5	2½	2¼-12	17/8-12	3	3.124	1	2½	—	5¼	2¾	4¼	5/8	¾	5/8	1/4	—	2¼	3¾	10½	11½	
	2	1¾-12	1½-12	2¼	2.624	7/8	111/16	—	4¼	15/16	323/32	5/8	1/4	1/2	1/4	—	2	3½	10½	12¼	
6	2½	2¼-12	17/8-12	3	3.124	1	2½	—	5¼	2¾	4¼	5/8	¾	5/8	1/4	—	2¼	3¾	10¾	12½	
	3	2¾-12	2¼-12	3½	3.749	1	25/8	—	5¾	27/8	57/16	7/8	¾	5/16	—	—	2¼	3½	10¾	12½	
6	3½	3¼-12	2½-12	3½	4.249	1	3	—	5¾	2¾	515/16	15/16	¾	5/16	—	—	2¼	3¾	10¾	12½	
	4	3¾-12	3-12	4	4.749	1	3¾	—	6¼	37/8	65/16	15/16	1/4	5/16	—	—	2¼	3½	12½	14½	

Table 3—Envelope and Mounting Dimensions

Rod End Dimensions (for Bolted Gland) – See Table 2

See chart on page 32 to determine which bore, rod and mount combinations have this feature.

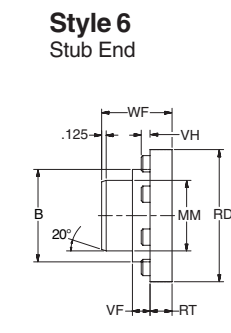
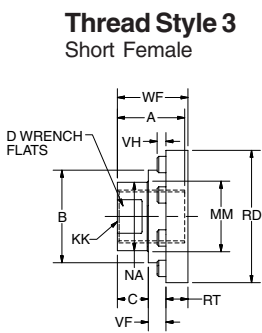
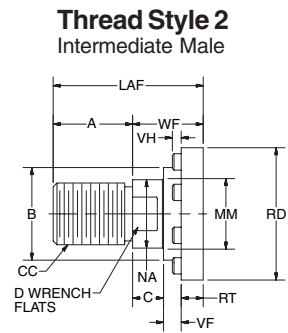
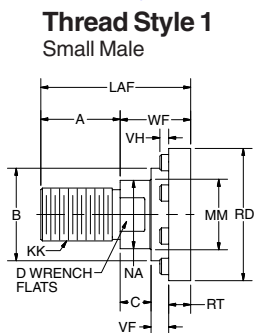

“Special” Thread Style 4

Special thread, extension, rod eye, blank, etc., are also available.

To order, specify “Style 4” and give desired dimensions for KK, A and WF. If otherwise special, furnish dimensioned sketch.

A high strength rod end stud is supplied on thread style 1 through 2” diameter rods. Larger sizes or special rod ends are cut threads. Style 1 rod ends are recommended where the workpiece is secured against the rod shoulder. When the workpiece is not shouldered,

style 1 rod ends are recommended through 2” piston rod diameters and style 2 rod ends are recommended on larger diameters. Use style 3 for applications where female rod end threads are required. If rod end is not specified, style 1 will be supplied.

Head Trunnion Mount
Style TM1

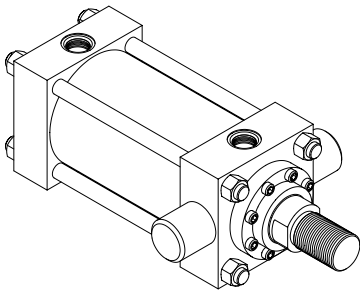

Maximum Pressure Rating - PSI

Bore	PSI
1 1/2	3000
2	3000
2 1/2	3000
3 1/4	2800
4	1800
5	1200
6	1000

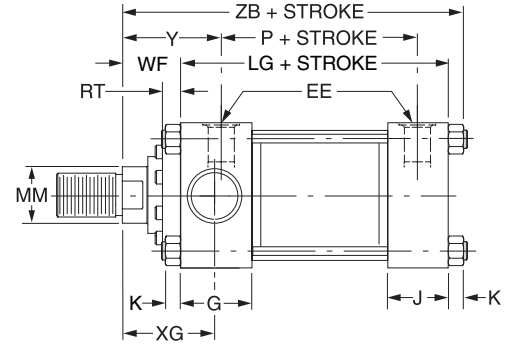
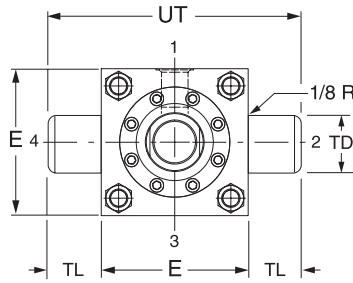

Cap Trunnion Mount
Style TM2

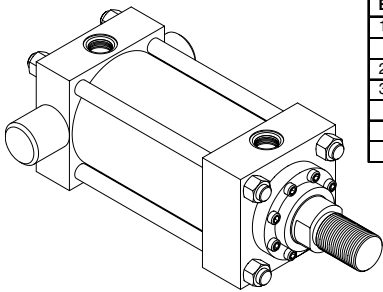

Maximum Pressure Rating - PSI

Bore	PSI
1 1/2	3000
2	3000
2 1/2	3000
3 1/4	2800
4	1800
5	1200
6	1000

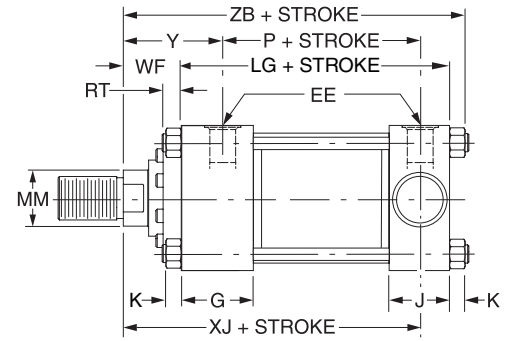
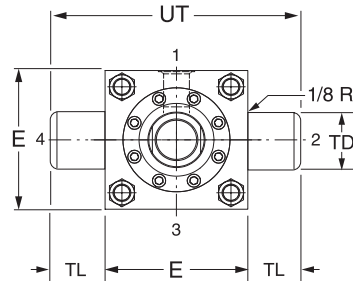

Intermediate Trunnion Mount
Style TM3

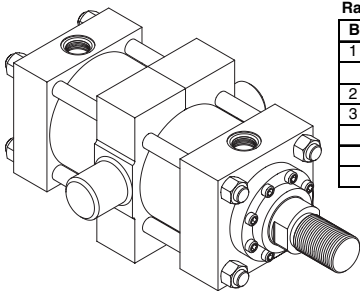

Maximum Pressure Rating - PSI

Bore	PSI
1 1/2	3000
2	3000
2 1/2	3000
3 1/4	2800
4	1800
5	1200
6	1000

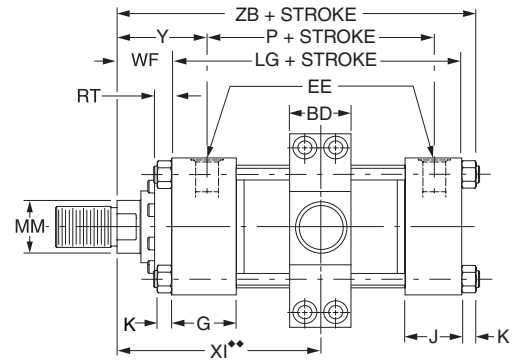
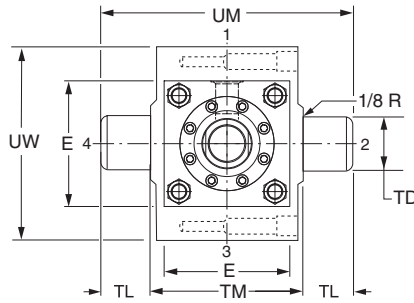

◆◆ Dimension XI to be specified by customer.

Rod End Dimensions (for Retainer Held Gland) – See Table 2

See chart on page 32 to determine which bore, rod and mount combinations have this feature.

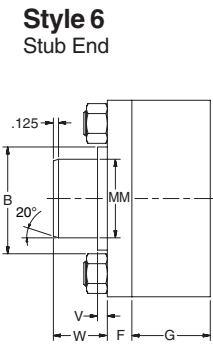
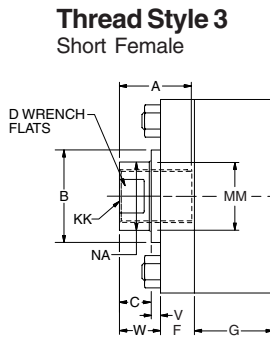
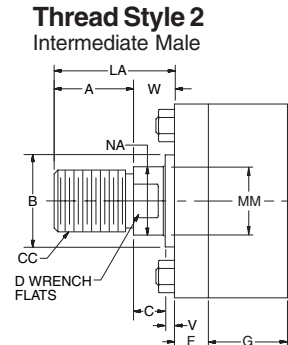
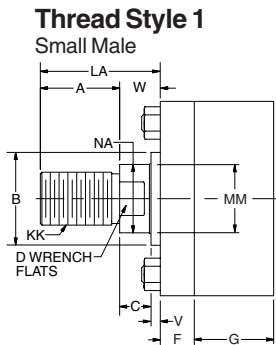

“Special” Thread Style 4

Special thread, extension, rod eye, blank, etc., are also available. To order, specify “Style 4” and give desired dimensions for KK, A and W. If otherwise special, furnish dimensioned sketch.

A high strength rod end stud is supplied on thread style 1 through 2" diameter rods. Larger sizes or special rod ends are cut threads. Style 1 rod ends are recommended where the workpiece is secured against the rod shoulder. When the workpiece is not shouldered,

style 1 rod ends are recommended through 2" piston rod diameters and style 2 rod ends are recommended on larger diameters. Use style 3 for applications where female rod end threads are required. If rod end is not specified, style 1 will be supplied.

Table 1—Envelope and Mounting Dimensions

Bore	BD	E	EE		F	G	J	K	+0.000 -0.001 TD	TL	TM	UM	UT	UW	Add Stroke		Style TM3 Minimum Stroke
			NPTF⊖	SAE★											LG	P	
1½	1¼	2½	½	8	⅜	1¾	1½	⅜	1.000	1	3	5	4½	3⅜	45/8	27/8	0
2	1½	3	½	8	5/8	1¾	1½	7/16	1.375	1⅜	3½	6¼	5¾	4⅛	45/8	27/8	¼
2½	1½	3½	½	8	5/8	1¾	1½	7/16	1.375	1⅜	4	6¾	6¼	45/8	4¾	3	⅛
3¼	2	4½	¾	12	¾	2	1¾	9/16	1.750	1¾	5	8½	8	5⅜	5½	3½	⅜
4	2	5	¾	12	7/8	2	1¾	9/16	1.750	1¾	5½	9	8½	6⅜	5¾	3¾	⅛
5	2	6½	¾	12	7/8	2	1¾	13/16	1.750	1¾	7	10½	10	7¾	6¼	4¼	0
6	3	7½	1	16	1	2¼	2¼	7/8	2.000	2	8½	12½	11½	10⅜	7⅜	47/8	¼

★ SAE straight thread ports are standard and are indicated by port number.
 ⊖ NPTF ports are available at no extra charge.

Table 2—Rod Dimensions

Bore	Rod Dia. MM	Thread		Rod Extensions and Pilot Dimensions														Add Stroke				
		Style 2 CC	Style 1 & 3 KK	A	+0.000 -0.002 B	C	D	LA	LAF	NA	RD (Max.)	RT	V	VF	VH	W	WF	XG	Min. XI◆◆	Y	XJ	ZB
1½	5/8	1/2-20	7/16-20	3/4	1.124	3/8	1/2	—	1¾	9/16	115/16	3/8	1/4	1/4	3/16	—	1	17/8	37/16	2	47/8	6
	1	7/8-14	3/4-16	11/8	1.499	1/2	7/8	2½	2½	15/16	2¾	3/8	1/2	1/2	3/16	1	13/8	21/4	313/16	2¾	5¼	6¾
2	1	7/8-14	3/4-16	11/8	1.499	1/2	7/8	—	2½	15/16	2¾	3/8	1/4	1/2	3/16	—	13/8	21/4	315/16	2¾	5¼	67/16
	1⅜	1¼-12	1-14	15/8	1.999	5/8	11/8	25/8	3¼	15/16	27/8	3/8	3/8	5/8	3/16	1	15/8	21/2	43/16	25/8	5½	611/16
2½	1	7/8-14	3/4-16	11/8	1.499	1/2	7/8	—	2½	15/16	2¾	3/8	1/4	1/2	3/16	—	13/8	21/4	315/16	2¾	5¾	69/16
	1⅜	1¼-12	1-14	15/8	1.999	5/8	11/8	—	3¼	15/16	27/8	3/8	3/8	5/8	3/16	—	15/8	21/2	43/16	25/8	55/8	613/16
3¼	1¾	1½-12	1¼-12	2	2.374	¾	1½	—	37/8	111/16	315/32	5/8	1/2	1/2	3/16	—	17/8	23/4	47/16	27/8	57/8	71/16
	1¾	1¼-12	1¼-12	15/8	1.999	5/8	11/8	—	3¼	15/16	27/8	3/8	1/4	5/8	3/16	—	15/8	25/8	411/16	2¾	6¼	711/16
4	2	1¾-12	1½-12	2¼	2.624	7/8	111/16	—	4¼	115/16	323/32	5/8	3/8	1/2	1/4	—	2	3	51/16	31/8	55/8	81/16
	1¾	1½-12	1¼-12	2	2.374	¾	1½	—	37/8	111/16	315/32	5/8	1/4	1/2	3/16	—	17/8	27/8	415/16	3	6½	715/16
5	2½	2¼-12	17/8-12	3	3.124	1	21/16	—	5¼	23/8	4¼	5/8	3/8	5/8	1/4	—	2¼	3¼	55/16	33/8	71/8	89/16
	2	1¾-12	1½-12	2¼	2.624	7/8	111/16	—	4¼	115/16	323/32	5/8	1/4	1/2	1/4	—	2	3	51/16	31/8	73/8	91/16
6	2½	2¼-12	17/8-12	3	3.124	1	21/16	—	5¼	23/8	4¼	5/8	3/8	5/8	1/4	—	2¼	3¼	55/16	33/8	75/8	95/16
	3	2¾-12	2¼-12	3½	3.749	1	25/8	—	5¾	27/8	57/16	7/8	3/8	5/16	—	—	2¼	3¼	55/16	33/8	75/8	95/16
6	3½	3¼-12	2½-12	3½	4.249	1	3	—	5¾	33/8	515/16	15/16	3/8	5/16	—	—	2¼	3¼	55/16	33/8	75/8	95/16
	2½	2¼-12	17/8-12	3	3.124	1	21/16	—	5¼	23/8	4¼	5/8	1/4	5/8	1/4	—	2¼	33/8	61/16	3½	83/8	10½
6	3	2¾-12	2¼-12	3½	3.749	1	25/8	—	5¾	27/8	57/16	7/8	1/4	5/16	—	—	2¼	33/8	61/16	3½	83/8	10½
	3½	3¼-12	2½-12	3½	4.249	1	3	—	5¾	33/8	515/16	15/16	1/4	5/16	—	—	2¼	33/8	61/16	3½	83/8	10½
6	4	3¾-12	3-12	4	4.749	1	33/8	—	6¼	37/8	65/16	15/16	1/4	5/16	—	—	2¼	33/8	61/16	3½	83/8	10½

◆◆ Dimension XI to be specified by customer.

Rod End Dimensions (for Bolted Gland) – See Table 2

See chart on page 32 to determine which bore, rod and mount combinations have this feature.

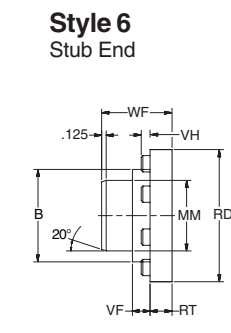
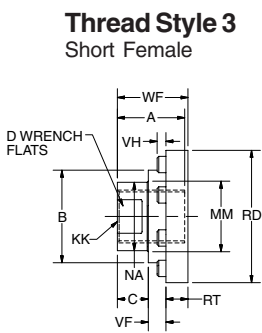
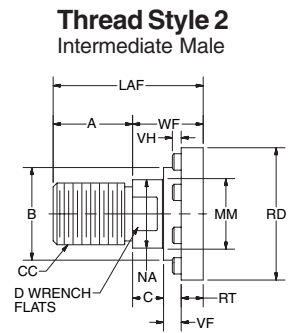
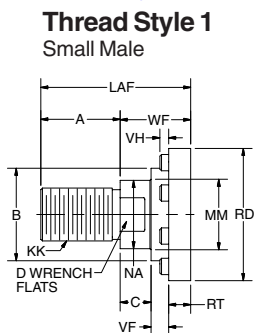

A high strength rod end stud is supplied on thread style 1 through 2" diameter rods. Larger sizes or special rod ends are cut threads. Style 1 rod ends are recommended where the workpiece is secured against the rod shoulder. When the workpiece is not shouldered,

style 1 rod ends are recommended through 2" piston rod diameters and style 2 rod ends are recommended on larger diameters. Use style 3 for applications where female rod end threads are required. If rod end is not specified, style 1 will be supplied.

Table 3—Envelope and Mounting Dimensions

Table 2—Rod Dimensions

NOTES

Series H 7" and 8" Bore Heavy Duty High Pressure Hydraulic Cylinders

- Bolted gland for ease of maintenance.
 - Hi-Load piston is standard.
 - Cylinder tube seal groove design and high-strength tie rods ensure trouble-free performance even in severe applications.
 - Floating cushions with float-check action and positive metal-to-metal seal.
- Every cylinder is *individually* tested before it leaves our plant.

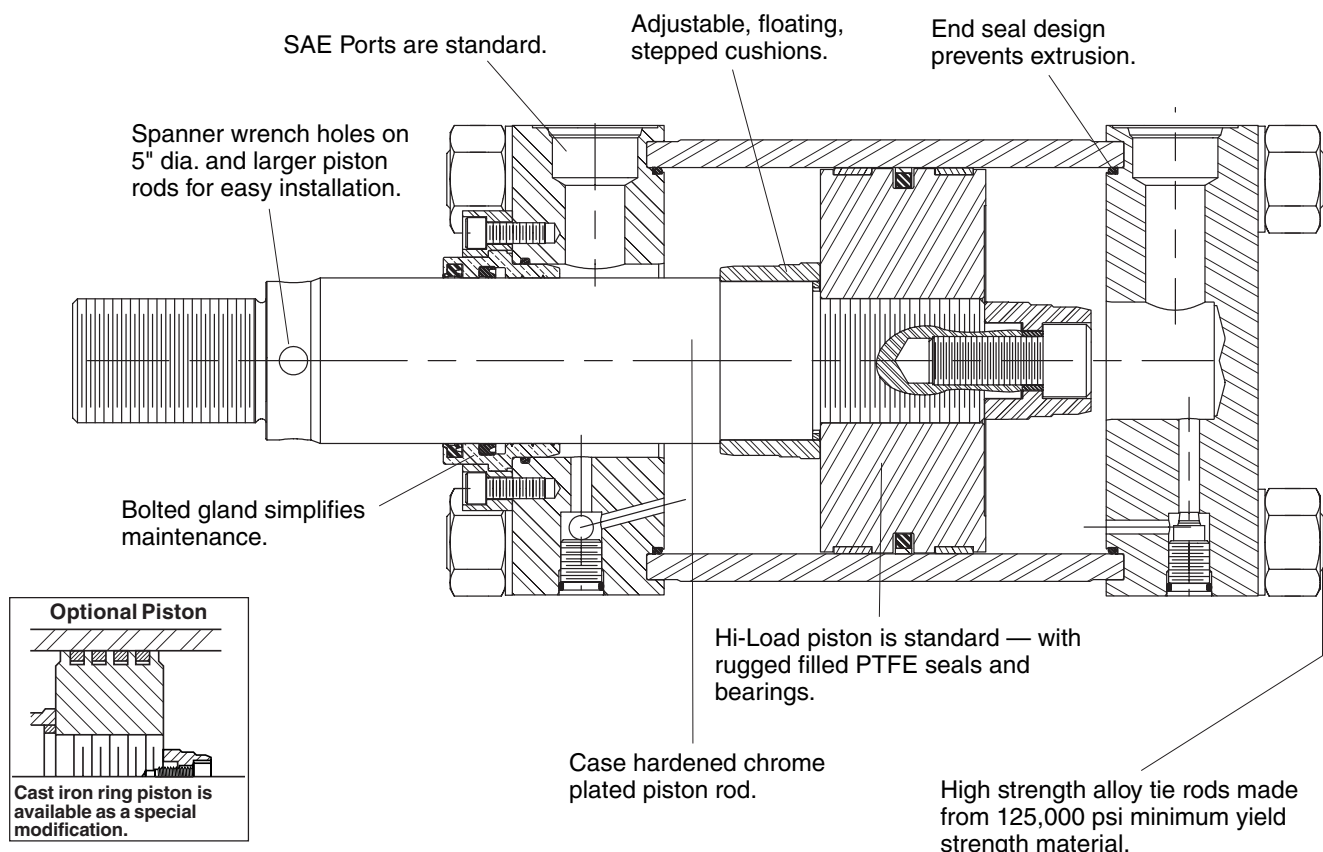

Standard Specifications

- Heavy Duty Service — ANSI/NFPA T.3.6.7R2-1996 specifications and mounting dimension standards
- Standard Construction — Square Head — Tie Rod Design
- Nominal Pressure — 3000 PSI*
- Standard Fluid — Hydraulic Oil
- Standard Temperature — -10° F. to +165° F.
- Piston Rod Diameter — 3" through 5 1/2"
- Mounting Styles — 15 standard styles at various application ratings
- Strokes — Available in any practical stroke length
- Cushions — Optional at either end or both ends of stroke
- Rod Ends — Four Standard Choices — specials to order

*If hydraulic operating pressure exceeds 3000 PSI, send application data for engineering evaluation and recommendation.
In line with our policy of continuing product improvement, specifications in this catalog are subject to change.

Tie Rods Extended Head End Mount
Style NM3

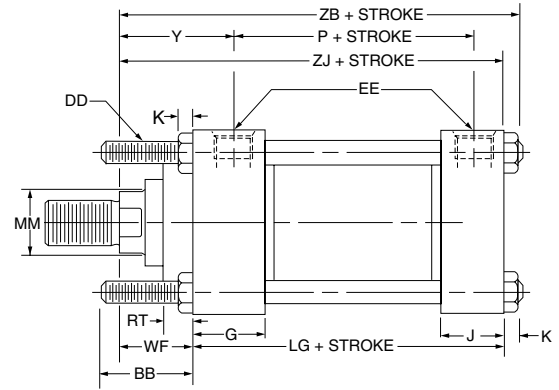
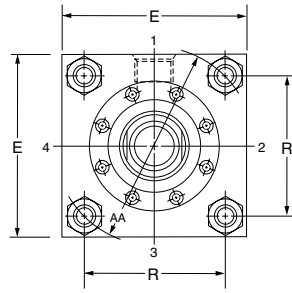
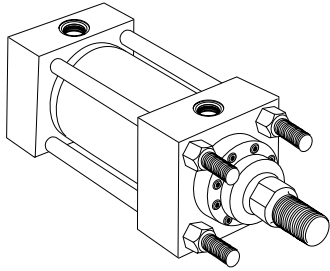

Tie Rods Extended Cap End Mount
Style NM2

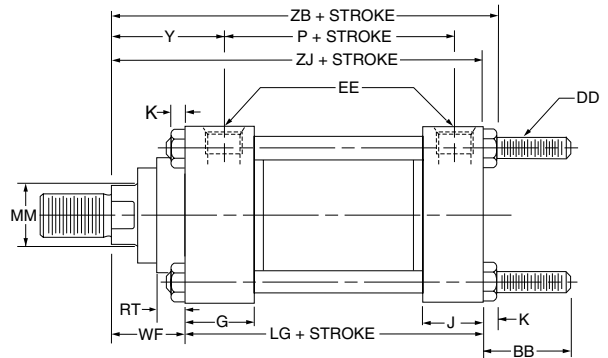
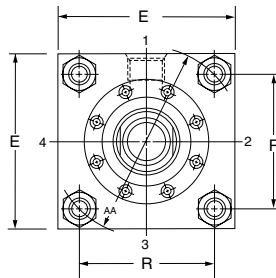
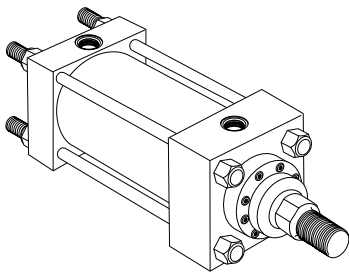

Tie Rods Extended Both Ends Mount
Style NM1

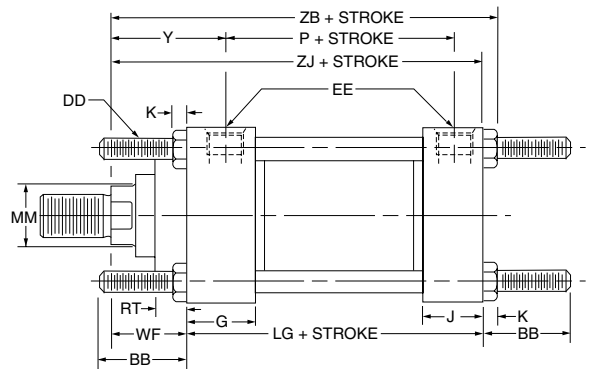
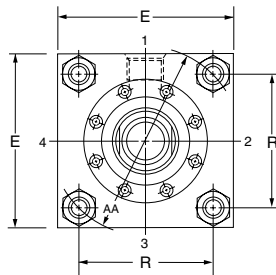
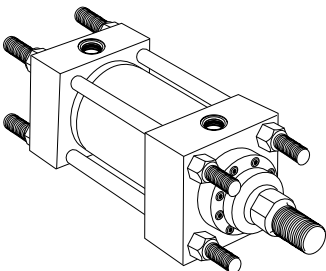

Rod End Dimensions — see Table 2

Thread Style 1
 Small Male

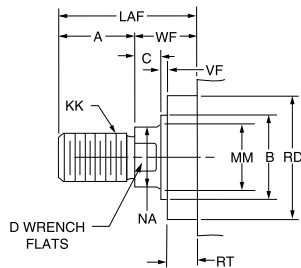

Thread Style 2
 Intermediate Male

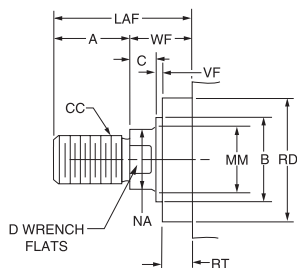

Thread Style 3
 Short Female

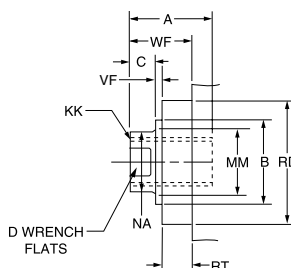

Style 6
 Stub End

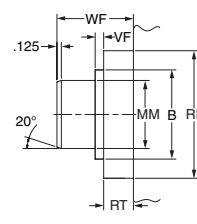

“Special” Thread Style 4

Special thread, extension, rod eye, blank, etc., are also available. To order, specify “Style 4” and give desired dimensions for KK, A and WF. If otherwise special, furnish dimensioned sketch.

Over 2" rod sizes or special rod ends are cut threads. Style 1 rod ends are recommended where the workpiece is secured against the rod shoulder. When the workpiece is not shouldered, style 2 rod ends are recommended over 2" piston rod diameters. Use style 3 for

applications where female rod end threads are required. If rod end is not specified, style 1 will be supplied. On 5" rods and above, (4) .515 dia. spanner wrench holes will be provided instead of wrench flats.

Table 1—Envelope and Mounting Dimensions

Bore	AA	BB	DD	E	EE		G	J	K	R	Add Stroke	
					NPTF⊖	SAE★					LG	P
7	9.3	4 1/8	1 1/8-12	8 1/2	1 1/4	20	2 3/4	2 3/4	1 1/4	6.58	8 1/2	5 1/2
8	10.6	4 1/2	1 1/4-12	9 1/2	1 1/2	24	3	3	1 1/2	7.50	9 1/2	6 1/4

★ SAE straight thread ports are standard and are indicated by port number.

⊖ NPTF ports are available at no extra charge.

**Table 3 —
Envelope and
Mounting
Dimensions**

Table 2—Rod Dimensions

Bore	Rod Dia. MM	Thread		Rod Extensions and Pilot Dimensions										Add Stroke		
		Style 2 CC	Style 1 & 3 KK	A	+0.000 -0.002 B	C	D	LAF	NA	RD (Max.)	RT	VF	WF	Y	ZB	ZJ
7	3	2 3/4-12	2 1/4-12	3 1/2	3.749	1	2 5/8	5 3/4	2 7/8	5 7/16	7/8	5/16	2 1/4	3 3/4	12	10 3/4
	5	4 3/4-12	3 1/2-12	5	5.749	1	—	7 1/4	4 7/8	7 7/16	15/16	5/16	2 1/4	3 3/4	12	10 3/4
	3 1/2	3 1/4-12	2 1/2-12	3 1/2	4.249	1	3	5 3/4	3 3/8	5 15/16	15/16	5/16	2 1/4	3 3/4	12	10 3/4
	4	3 3/4-12	3-12	4	4.749	1	3 3/8	6 1/4	3 7/8	6 5/16	15/16	5/16	2 1/4	3 3/4	12	10 3/4
8	3 1/2	3 1/4-12	2 1/2-12	3 1/2	4.249	1	3	5 3/4	3 3/8	5 15/16	15/16	5/16	2 1/4	3 7/8	13 1/4	11 3/4
	5 1/2	5 1/4-12	4-12	5 1/2	6.249	1	—	7 3/4	5 3/8	7 15/16	15/16	5/16	2 1/4	3 7/8	13 1/4	11 3/4
	4	3 3/4-12	3-12	4	4.749	1	3 3/8	6 1/4	3 7/8	6 5/16	15/16	5/16	2 1/4	3 7/8	13 1/4	11 3/4
	5	4 3/4-12	3 1/2-12	5	5.749	1	—	7 1/4	4 7/8	7 7/16	15/16	5/16	2 1/4	3 7/8	13 1/4	11 3/4

Head Rectangular Flange Mount
Style REF2

Maximum Pressure Rating - PSI
 Push Application

Bore	Rod Dia				
	3	3 1/2	4	5	5 1/2
7	1000	800	400	400	-
8	-	800	700	400	400

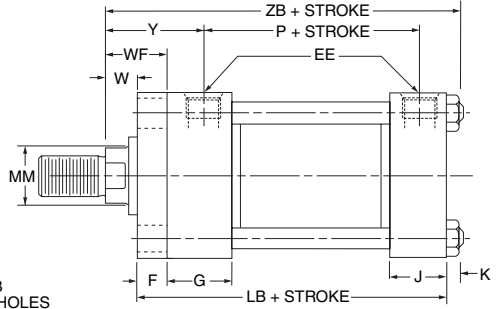
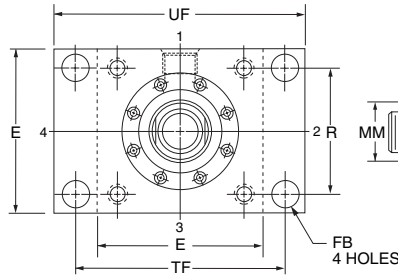
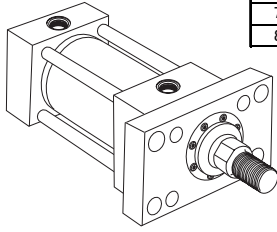

For pressures exceeding those shown use Style REF1 or Style ME5.

Head Square Flange Mount
Style REF1

Maximum Pressure Rating - PSI
 Push Application

Bore	Rod Dia				
	3	3 1/2	4	5	5 1/2
7	2500	2200	1500	1500	-
8	-	2000	2000	1400	1400

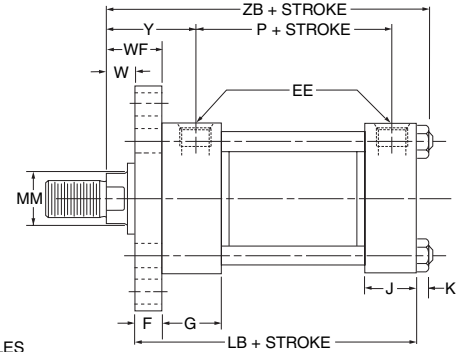
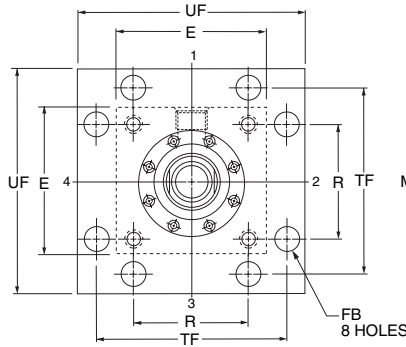
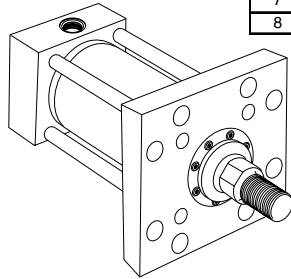

Head Rectangular Mount
Style ME5

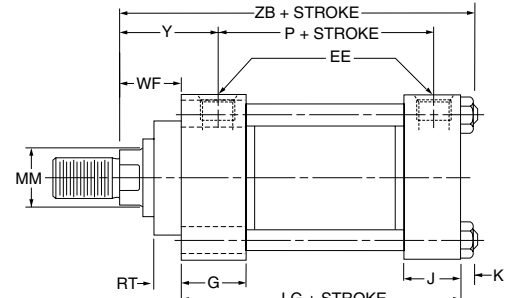
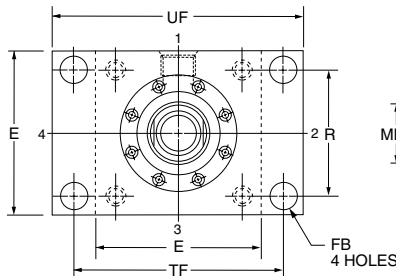
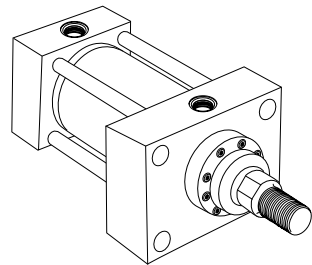

Rod End Dimensions — see Table 2

Thread Style 1
 Small Male

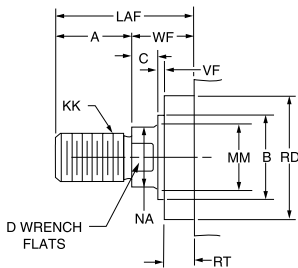

Thread Style 2
 Intermediate Male

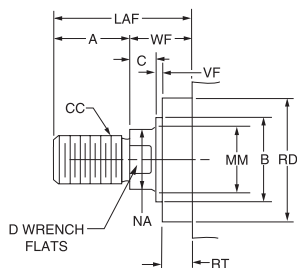

Thread Style 3
 Short Female

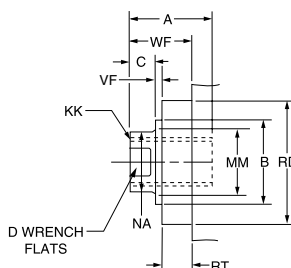

Style 6
 Stub End

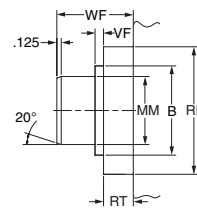

“Special” Thread Style 4

Special thread, extension, rod eye, blank, etc., are also available. To order, specify “Style 4” and give desired dimensions for KK, A and WF. If otherwise special, furnish dimensioned sketch.

Over 2" rod sizes or special rod ends are cut threads. Style 1 rod ends are recommended where the workpiece is secured against the rod shoulder. When the workpiece is not shouldered, style 2 rod ends are recommended over 2" piston rod diameters. Use style 3 for

applications where female rod end threads are required. If rod end is not specified, style 1 will be supplied. On 5" rods and above, (4) .515 dia. spanner wrench holes will be provided instead of wrench flats.

Table 1—Envelope and Mounting Dimensions

Bore	E	EE		F	FB	G	J	K	R	TF	UF	Add Stroke		
		NPTF⊖	SAE★									LB	LG	P
7	8½	1¼	20	1	1⅜	2¾	2¾	1¼	6.58	10 ⁵ / ₈	12 ⁵ / ₈	9½	8½	5½
8	9½	1½	24	1	1 ⁵ / ₁₆	3	3	1½	7.50	11 ¹³ / ₁₆	14	10½	9½	6¼

★ SAE straight thread ports are standard and are indicated by port number.
⊖ NPTF ports are available at no extra charge.

Table 2—Rod Dimensions

Bore	Rod Dia. MM	Thread		Rod Extensions and Pilot Dimensions											Add Stroke	
		Style 2 CC	Style 1 & 3 KK	A	+0.000 -0.002 B	C	D	LAF	NA	RD (Max.)	RT	VF	W	WF		Y
7	3	2¾-12	2¼-12	3½	3.749	1	2 ⁵ / ₈	5¾	2 ⁷ / ₈	5 ⁷ / ₁₆	7/8	5/16	1¼	2¼	3¾	12
	5	4¾-12	3½-12	5	5.749	1	—	7¼	4 ⁷ / ₈	7 ⁷ / ₁₆	1 ⁵ / ₁₆	5/16	1¼	2¼	3¾	12
	3½	3¼-12	2½-12	3½	4.249	1	3	5¾	3 ³ / ₈	5 ¹⁵ / ₁₆	1 ⁵ / ₁₆	5/16	1¼	2¼	3¾	12
	4	3¾-12	3-12	4	4.749	1	3 ³ / ₈	6¼	3 ⁷ / ₈	6 ⁵ / ₁₆	1 ⁵ / ₁₆	5/16	1¼	2¼	3¾	12
8	3½	3¼-12	2½-12	3½	4.249	1	3	5¾	3 ³ / ₈	5 ¹⁵ / ₁₆	1 ⁵ / ₁₆	5/16	1¼	2¼	3 ⁷ / ₈	13¼
	5½	5¼-12	4-12	5½	6.249	1	—	7¾	5 ³ / ₈	7 ¹⁵ / ₁₆	1 ⁵ / ₁₆	5/16	1¼	2¼	3 ⁷ / ₈	13¼
	4	3¾-12	3-12	4	4.749	1	3 ³ / ₈	6¼	3 ⁷ / ₈	6 ⁵ / ₁₆	1 ⁵ / ₁₆	5/16	1¼	2¼	3 ⁷ / ₈	13¼
	5	4¾-12	3½-12	5	5.749	1	—	7¼	4 ⁷ / ₈	7 ⁷ / ₁₆	1 ⁵ / ₁₆	5/16	1¼	2¼	3 ⁷ / ₈	13¼

**Table 3 —
Envelope and
Mounting
Dimensions**

**Cap Rectangular
 Flange Mount
 Style BEF2**

Maximum Pressure Rating - PSI
 Pull Application

Bore	Rod Dia				
	3	3 1/2	4	5	5 1/2
7	2000	2000	2500	3000	-
8	-	1700	1700	2200	2500

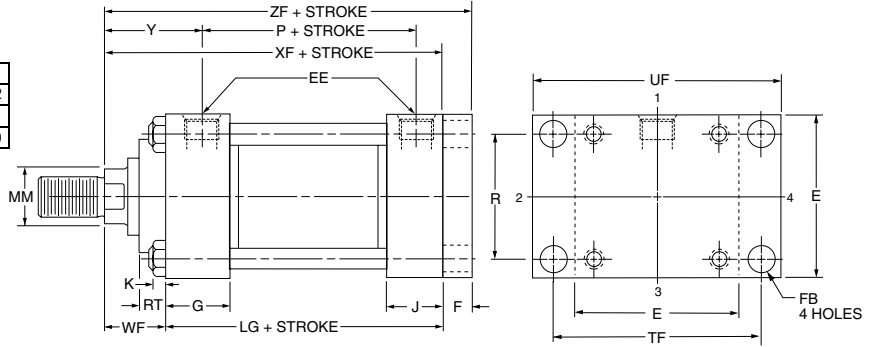
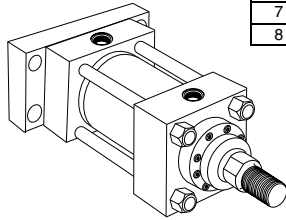

For pressures exceeding those shown use Style BEF1 or Style ME6.

**Cap Square Flange Mount
 Style BEF1**

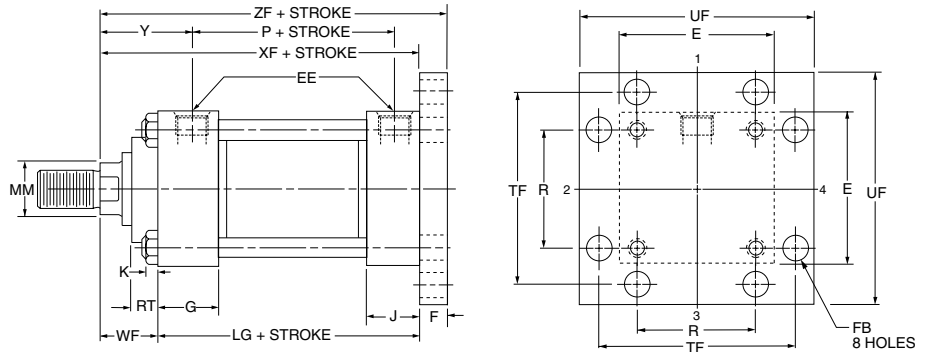
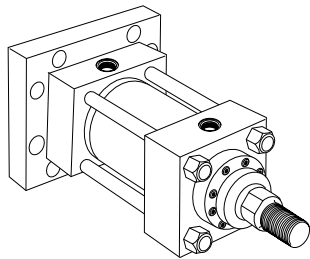

**Cap Rectangular Mount
 Style ME6**

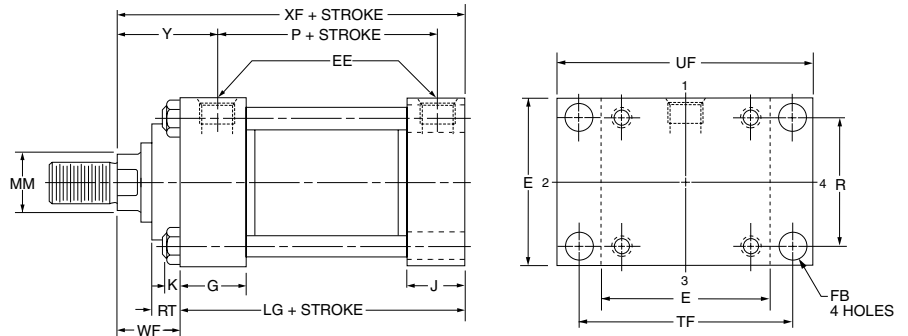
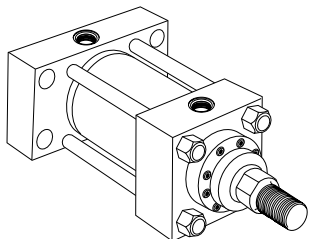

Rod End Dimensions — see Table 2

Thread Style 1
 Small Male

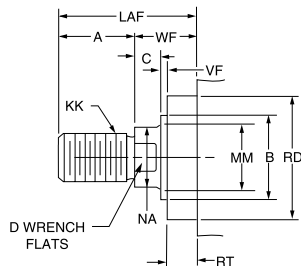

Thread Style 2
 Intermediate Male

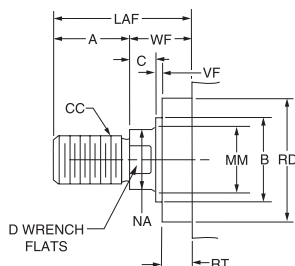

Thread Style 3
 Short Female

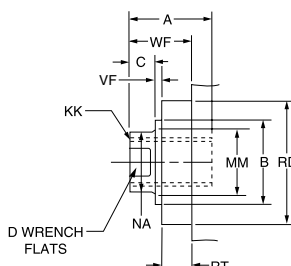

Style 6
 Stub End

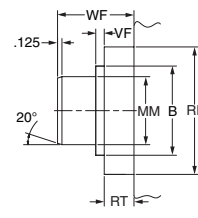

**“Special” Thread
 Style 4**

Special thread, extension, rod eye, blank, etc., are also available.

To order, specify “Style 4” and give desired dimensions for KK, A and WF. If otherwise special, furnish dimensioned sketch.

Over 2" rod sizes or special rod ends are cut threads. Style 1 rod ends are recommended where the workpiece is secured against the rod shoulder. When the workpiece is not shouldered, style 2 rod ends are recommended over 2" piston rod diameters. Use style 3 for

applications where female rod end threads are required. If rod end is not specified, style 1 will be supplied. On 5" rods and above, (4) .515 dia. spanner wrench holes will be provided instead of wrench flats.

Table 1—Envelope and Mounting Dimensions

Bore	E	EE		F	FB	G	J	K	R	TF	UF	Add Stroke	
		NPTF \ominus	SAE \star									LG	P
7	8 $\frac{1}{2}$	1 $\frac{1}{4}$	20	1	1 $\frac{3}{16}$	2 $\frac{3}{4}$	2 $\frac{3}{4}$	1 $\frac{1}{4}$	6.58	10 $\frac{5}{8}$	12 $\frac{5}{8}$	8 $\frac{1}{2}$	5 $\frac{1}{2}$
8	9 $\frac{1}{2}$	1 $\frac{1}{2}$	24	1	1 $\frac{5}{16}$	3	3	1 $\frac{1}{2}$	7.50	11 $\frac{13}{16}$	14	9 $\frac{1}{2}$	6 $\frac{1}{4}$

\star SAE straight thread ports are standard and are indicated by port number.
 \ominus NPTF ports are available at no extra charge.

Table 2—Rod Dimensions

Bore	Rod Dia. MM	Thread		Rod Extensions and Pilot Dimensions										Add Stroke		
		Style 2 CC	Style 1 & 3 KK	A	+0.000 -0.002 B	C	D	LAF	NA	RD (Max.)	RT	VF	WF	Y	XF	ZF
7	3	2 $\frac{3}{4}$ -12	2 $\frac{1}{4}$ -12	3 $\frac{1}{2}$	3.749	1	2 $\frac{5}{8}$	5 $\frac{3}{4}$	2 $\frac{7}{8}$	5 $\frac{7}{16}$	7 $\frac{7}{8}$	5 $\frac{1}{16}$	2 $\frac{1}{4}$	3 $\frac{3}{4}$	10 $\frac{3}{4}$	11 $\frac{3}{4}$
	5	4 $\frac{3}{4}$ -12	3 $\frac{1}{2}$ -12	5	5.749	1	—	7 $\frac{1}{4}$	4 $\frac{7}{8}$	7 $\frac{7}{16}$	15 $\frac{1}{16}$	5 $\frac{1}{16}$	2 $\frac{1}{4}$	3 $\frac{3}{4}$	10 $\frac{3}{4}$	11 $\frac{3}{4}$
	3 $\frac{1}{2}$	3 $\frac{1}{4}$ -12	2 $\frac{1}{2}$ -12	3 $\frac{1}{2}$	4.249	1	3	5 $\frac{3}{4}$	3 $\frac{3}{8}$	5 $\frac{15}{16}$	15 $\frac{1}{16}$	5 $\frac{1}{16}$	2 $\frac{1}{4}$	3 $\frac{3}{4}$	10 $\frac{3}{4}$	11 $\frac{3}{4}$
	4	3 $\frac{3}{4}$ -12	3-12	4	4.749	1	3 $\frac{3}{8}$	6 $\frac{1}{4}$	3 $\frac{7}{8}$	6 $\frac{5}{16}$	15 $\frac{1}{16}$	5 $\frac{1}{16}$	2 $\frac{1}{4}$	3 $\frac{3}{4}$	10 $\frac{3}{4}$	11 $\frac{3}{4}$
8	3 $\frac{1}{2}$	3 $\frac{1}{4}$ -12	2 $\frac{1}{2}$ -12	3 $\frac{1}{2}$	4.249	1	3	5 $\frac{3}{4}$	3 $\frac{3}{8}$	5 $\frac{15}{16}$	15 $\frac{1}{16}$	5 $\frac{1}{16}$	2 $\frac{1}{4}$	3 $\frac{7}{8}$	11 $\frac{3}{4}$	12 $\frac{3}{4}$
	5 $\frac{1}{2}$	5 $\frac{1}{4}$ -12	4-12	5 $\frac{1}{2}$	6.249	1	—	7 $\frac{3}{4}$	5 $\frac{3}{8}$	7 $\frac{15}{16}$	15 $\frac{1}{16}$	5 $\frac{1}{16}$	2 $\frac{1}{4}$	3 $\frac{7}{8}$	11 $\frac{3}{4}$	12 $\frac{3}{4}$
	4	3 $\frac{3}{4}$ -12	3-12	4	4.749	1	3 $\frac{3}{8}$	6 $\frac{1}{4}$	3 $\frac{7}{8}$	6 $\frac{5}{16}$	15 $\frac{1}{16}$	5 $\frac{1}{16}$	2 $\frac{1}{4}$	3 $\frac{7}{8}$	11 $\frac{3}{4}$	12 $\frac{3}{4}$
	5	4 $\frac{3}{4}$ -12	3 $\frac{1}{2}$ -12	5	5.749	1	—	7 $\frac{1}{4}$	4 $\frac{7}{8}$	7 $\frac{7}{16}$	15 $\frac{1}{16}$	5 $\frac{1}{16}$	2 $\frac{1}{4}$	3 $\frac{7}{8}$	11 $\frac{3}{4}$	12 $\frac{3}{4}$

**Table 3—
Envelope and
Mounting
Dimensions**

Side Lug Mount
Style SL

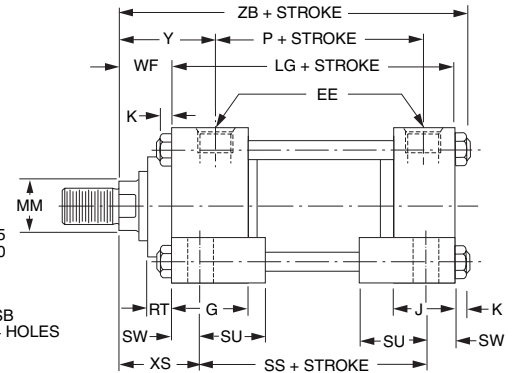
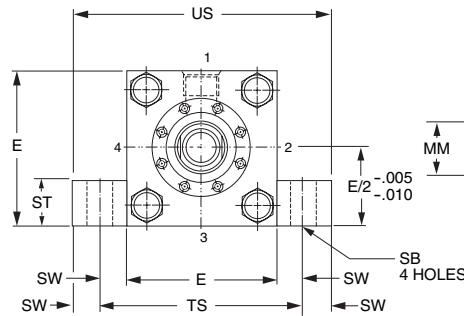
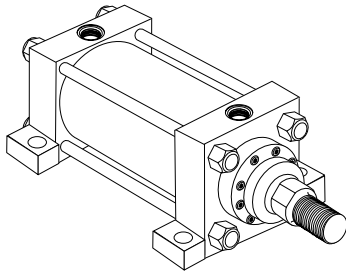

Style SL cylinders have mounting lugs welded to the head and cap, and are considered to be a fixed mount that does not absorb force on its centerline. The plane of the mounting surface is not through the centerline of the cylinder, and for this reason **Style SL** cylinders produce a turning moment as the cylinder applies force to the load. This turning moment tends to rotate the cylinder about its mounting

bolts. If the cylinder is not well secured to the machine member on which it is mounted or the load is not well-guided, this turning moment results in side load applied to rod gland and piston bearings. **To avoid this problem, Style SL cylinders should be specified with a stroke length at least equal to the bore size.**

Side Tap Mount
Style FS

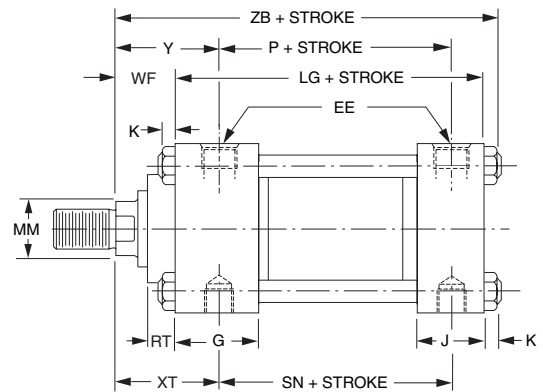
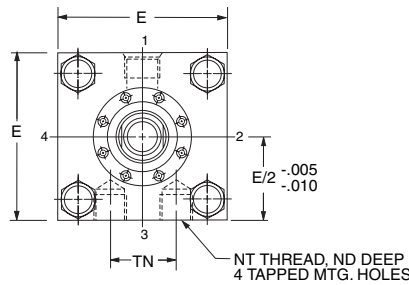
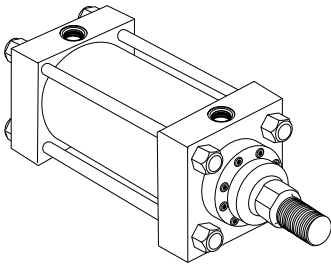

Style FS cylinders have side tapped holes for flush mounting, and are considered to be a fixed mount that does not absorb force on its centerline. The plane of the mounting surface is not through the centerline of the cylinder, and for this reason **Style FS** cylinders produce a turning moment as the cylinder applies force to the load. This turning moment tends to rotate the cylinder about its mounting

bolts. If the cylinder is not well secured to the machine member on which it is mounted or the load is not well-guided, this turning moment results in side load applied to rod gland and piston bearings. **To avoid this problem, Style FS cylinders should be specified with a stroke length at least equal to the bore size.**

Rod End Dimensions — see Table 2

Thread Style 1
 Small Male

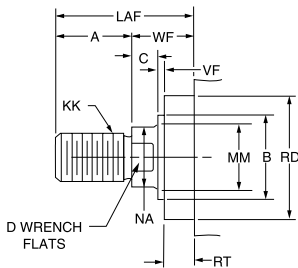

Thread Style 2
 Intermediate Male

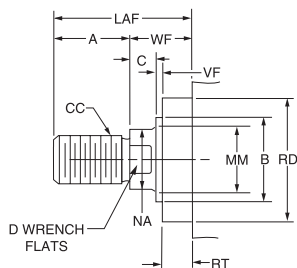

Thread Style 3
 Short Female

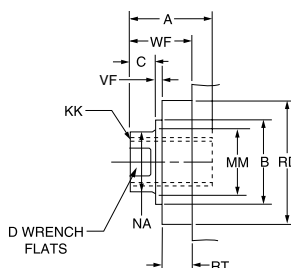

Style 6
 Stub End

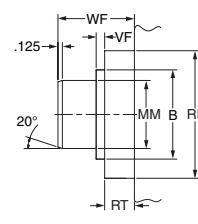

“Special” Thread Style 4

Special thread, extension, rod eye, blank, etc., are also available. To order, specify “Style 4” and give desired dimensions for KK, A and WF. If otherwise special, furnish dimensioned sketch.

Over 2" rod sizes or special rod ends are cut threads. Style 1 rod ends are recommended where the workpiece is secured against the rod shoulder. When the workpiece is not shouldered, style 2 rod ends are recommended over 2" piston rod diameters. Use style 3 for

applications where female rod end threads are required. If rod end is not specified, style 1 will be supplied. On 5" rods and above, (4) .515 dia. spanner wrench holes will be provided instead of wrench flats.

Table 1—Envelope and Mounting Dimensions

Bore	E	EE		G	J	K	NT	SB	ST	SU	SW	TN	TS	US	Add Stroke			
		NPTF [⊖]	SAE★												LG	P	SN	SS
7	8 1/2	1 1/4	20	2 3/4	2 3/4	1 1/4	1 1/2-6	1 9/16	1 3/4	2 7/8	1 3/8	3 3/4	11 1/4	14	8 1/2	5 1/2	5 7/8	5 3/4
8	9 1/2	1 1/2	24	3	3	1 1/2	1 1/2-6	1 9/16	1 3/4	2 7/8	1 3/8	4 1/4	12 1/4	15	9 1/2	6 1/4	6 5/8	6 3/4

★ SAE straight thread ports are standard and are indicated by port number.

⊖ NPTF ports are available at no extra charge.

Table 2—Rod Dimensions

Bore	Rod Dia. MM	Thread		Rod Extensions and Pilot Dimensions										ND	XS	XT	Y	ZB	Add Stroke
		Style 2 CC	Style 1 & 3 KK	A	+0.002 B	C	D	LAF	NA	RD (Max.)	RT	VF	WF						
7	3	2 3/4-12	2 1/4-12	3 1/2	3.749	1	2 5/8	5 3/4	2 7/8	5 7/16	7/8	5/16	2 1/4	1 1/8	3 5/8	3 13/16	3 3/4	12	
	5	4 3/4-12	3 1/2-12	5	5.749	1	—	7 1/4	4 7/8	7 7/16	15/16	5/16	2 1/4	1 1/8	3 5/8	3 13/16	3 3/4	12	
	3 1/2	3 1/4-12	2 1/2-12	3 1/2	4.249	1	3	5 3/4	3 3/8	5 15/16	15/16	5/16	2 1/4	1 1/8	3 5/8	3 13/16	3 3/4	12	
	4	3 3/4-12	3-12	4	4.749	1	3 3/8	6 1/4	3 7/8	6 5/16	15/16	5/16	2 1/4	1 1/8	3 5/8	3 13/16	3 3/4	12	
8	3 1/2	3 1/4-12	2 1/2-12	3 1/2	4.249	1	3	5 3/4	3 3/8	5 15/16	15/16	5/16	2 1/4	1 1/2	3 5/8	3 15/16	3 7/8	13 1/4	
	5 1/2	5 1/4-12	4-12	5 1/2	6.249	1	—	7 3/4	5 3/8	7 15/16	15/16	5/16	2 1/4	1 5/16	3 5/8	3 15/16	3 7/8	13 1/4	
	4	3 3/4-12	3-12	4	4.749	1	3 3/8	6 1/4	3 7/8	6 5/16	15/16	5/16	2 1/4	1 1/2	3 5/8	3 15/16	3 7/8	13 1/4	
	5	4 3/4-12	3 1/2-12	5	5.749	1	—	7 1/4	4 7/8	7 7/16	15/16	5/16	2 1/4	1 1/2	3 5/8	3 15/16	3 7/8	13 1/4	

**Table 3 —
Envelope and
Mounting
Dimensions**

Cap Fixed Clevis Mount
Style PB2

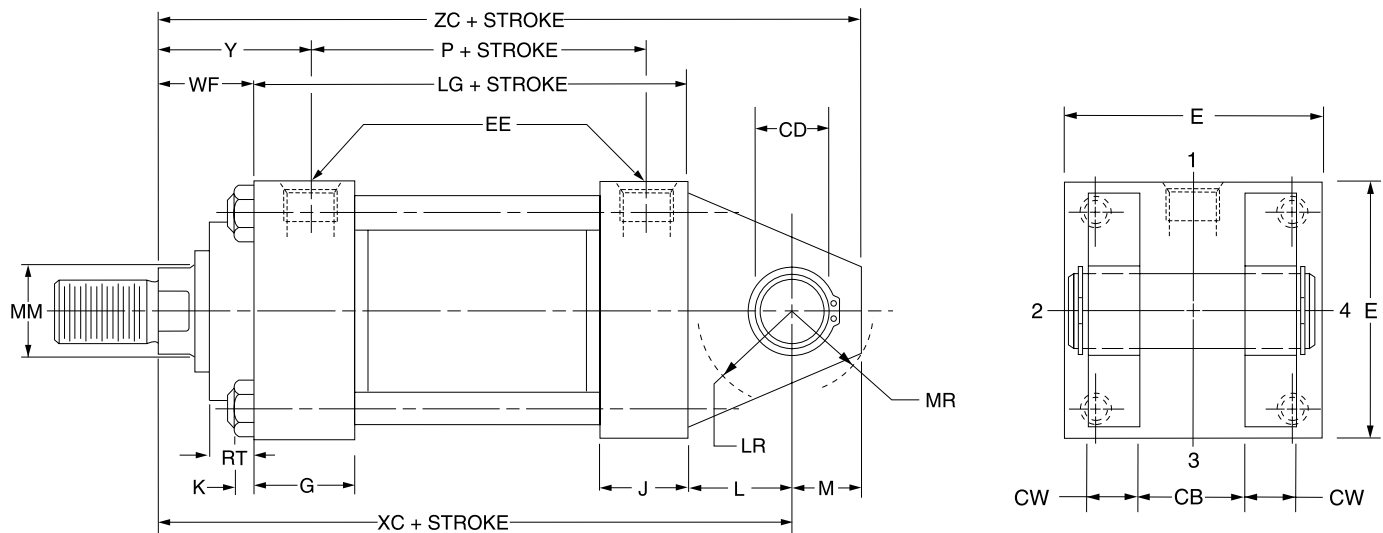
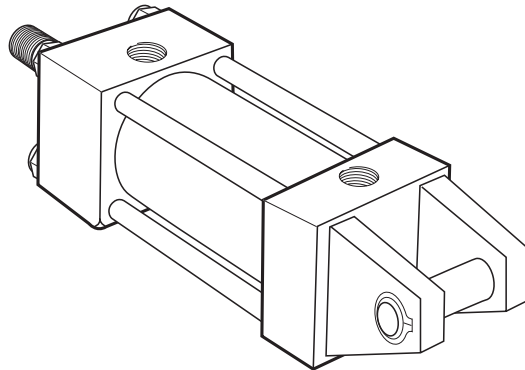

Rod End Dimensions — see Table 2

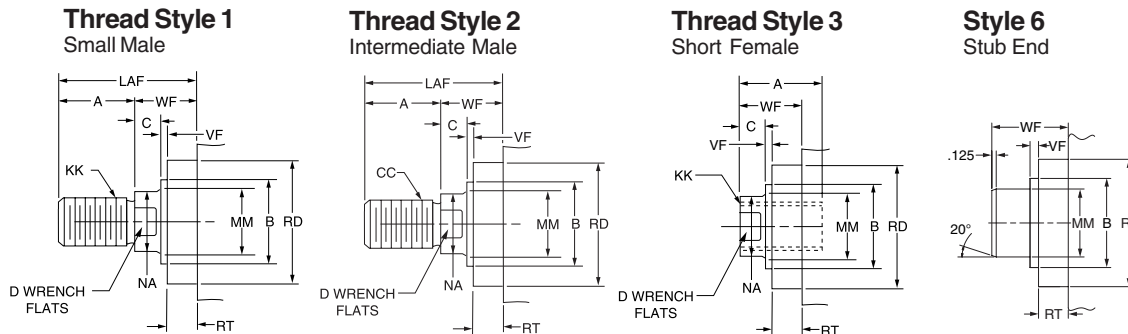

“Special” Thread Style 4

Special thread, extension, rod eye, blank, etc., are also available.

To order, specify “Style 4” and give desired dimensions for KK, A and WF. If otherwise special, furnish dimensioned sketch.

Over 2" rod sizes or special rod ends are cut threads. Style 1 rod ends are recommended where the workpiece is secured against the rod shoulder. When the workpiece is not shouldered, style 2 rod ends are recommended over 2" piston rod diameters. Use style 3 for

applications where female rod end threads are required. If rod end is not specified, style 1 will be supplied. On 5" rods and above, (4) .515 dia. spanner wrench holes will be provided instead of wrench flats.

Table 1—Envelope and Mounting Dimensions

Bore	CB	+.000 -.002 CD†	CW	E	EE		G	J	K	L	LR	M	MR	R	Add Stroke	
					NPTF⊖	SAE★									LG	P
7	3	2.501	1½	8½	1¼	20	2¾	2¾	1¼	3	2¾	2½	27/8	6.58	8½	5½
8	3	3.001	1½	9½	1½	24	3	3	1½	3¼	3¼	2¾	3½	7.50	9½	6¼

★ SAE straight thread ports are standard and are indicated by port number.

⊖ NPTF ports are available at no extra charge.

† Dimension CD is pin diameter.

Table 2—Rod Dimensions

Bore	Rod Dia. MM	Thread		Rod Extensions and Pilot Dimensions										Add Stroke		
		Style 2 CC	Style 1 & 3 KK	A	+.000 -.002 B	C	D	LAF	NA	RD (Max.)	RT	VF	WF	Y	XC	ZC
7	3	2¾-12	2¼-12	3½	3.749	1	25/8	5¾	27/8	57/16	7/8	5/16	2¼	3¾	13¾	16¼
	5	4¾-12	3½-12	5	5.749	1	—	7¼	47/8	77/16	15/16	5/16	2¼	3¾	13¾	16¼
	3½	3¼-12	2½-12	3½	4.249	1	3	5¾	3¾	515/16	15/16	5/16	2¼	3¾	13¾	16¼
	4	3¾-12	3-12	4	4.749	1	3¾	6¼	37/8	65/16	15/16	5/16	2¼	3¾	13¾	16¼
8	3½	3¼-12	2½-12	3½	4.249	1	3	5¾	3¾	515/16	15/16	5/16	2¼	37/8	15	17¾
	5½	5¼-12	4-12	5½	6.249	1	—	7¾	5¾	715/16	15/16	5/16	2¼	37/8	15	17¾
	4	3¾-12	3-12	4	4.749	1	3¾	6¼	37/8	65/16	15/16	5/16	2¼	37/8	15	17¾
	5	4¾-12	3½-12	5	5.749	1	—	7¼	47/8	77/16	15/16	5/16	2¼	37/8	15	17¾

**Table 3—
Envelope and
Mounting
Dimensions**

**Head Trunnion Mount
Style TM1**

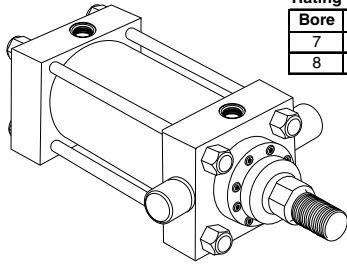

Maximum Pressure Rating - PSI	
Bore	PSI
7	1100
8	1100

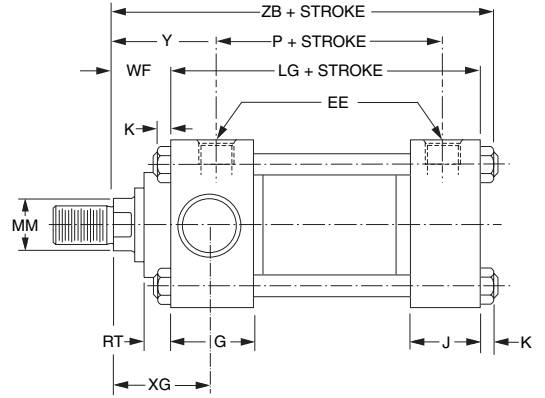
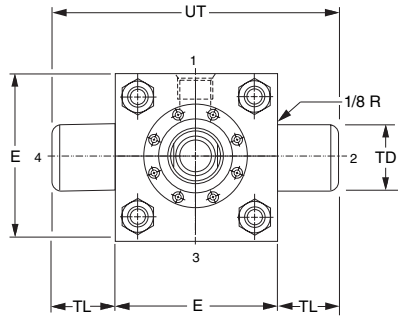

**Cap Trunnion Mount
Style TM2**

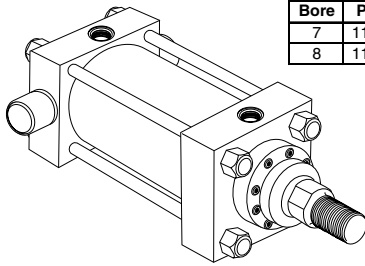

Maximum Pressure Rating - PSI	
Bore	PSI
7	1100
8	1100

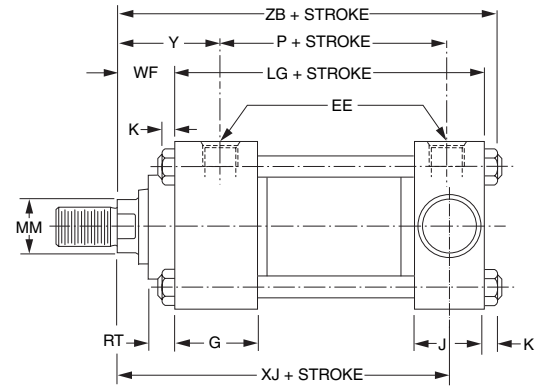
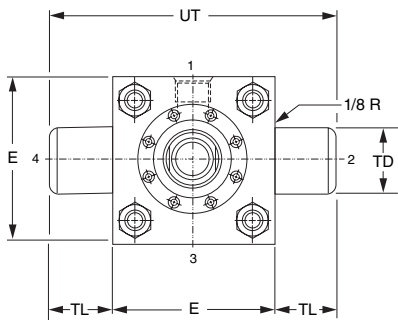

**Intermediate Trunnion Mount
Style TM3**

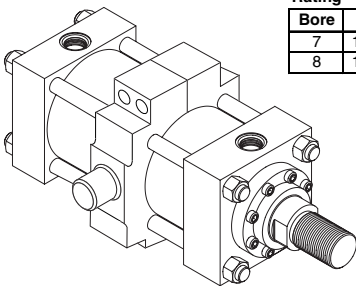

Maximum Pressure Rating - PSI	
Bore	PSI
7	1100
8	1100

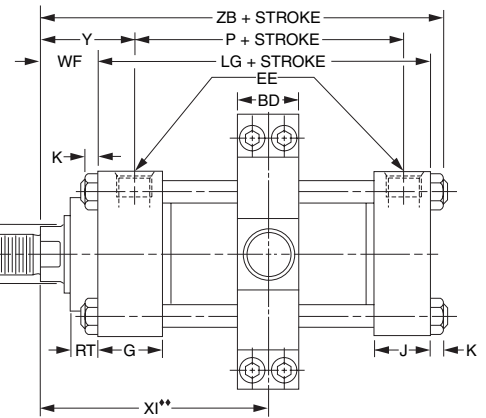
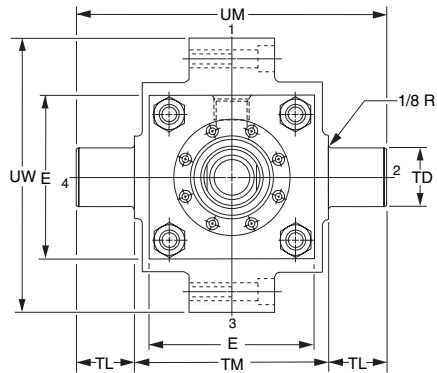

◆◆ Dimension XI to be specified by customer.

Rod End Dimensions — see Table 2

**Thread Style 1
Small Male**

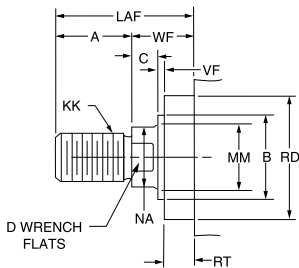

**Thread Style 2
Intermediate Male**

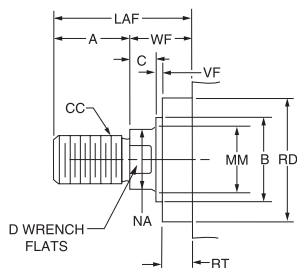

**Thread Style 3
Short Female**

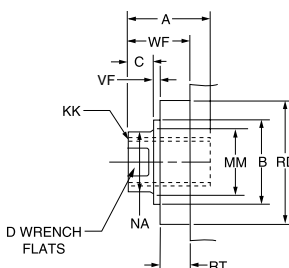

**Style 6
Stub End**

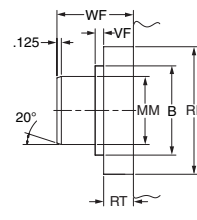

**“Special” Thread
Style 4**

Special thread, extension, rod eye, blank, etc., are also available. To order, specify “Style 4” and give desired dimensions for KK, A and WF. If otherwise special, furnish dimensioned sketch.

Over 2" rod sizes or special rod ends are cut threads. Style 1 rod ends are recommended where the workpiece is secured against the rod shoulder. When the workpiece is not shouldered, style 2 rod ends are recommended over 2" piston rod diameters. Use style 3 for

applications where female rod end threads are required. If rod end is not specified, style 1 will be supplied. On 5" rods and above, (4) .515 dia. spanner wrench holes will be provided instead of wrench flats.

Table 1—Envelope and Mounting Dimensions

Bore	BD	E	EE		G	J	K	+.000 -.002 TD	TL	TM	UM	UT	UW	Add Stroke	
			NPTF⊖	SAE★										LG	P
7	3	8 1/2	1 1/4	20	2 3/4	2 3/4	1 1/4	2.500	2 1/2	9 3/4	14 3/4	13 1/2	11 1/2	8 1/2	5 1/2
8	3 1/2	9 1/2	1 1/2	24	3	3	1 1/2	3.000	3	11	17	15 1/2	13 3/8	9 1/2	6 1/4

★ SAE straight thread ports are standard and are indicated by port number.
⊖ NPTF ports are available at no extra charge.

Table 2—Rod Dimensions

Bore	Rod Dia. MM	Thread		Rod Extensions and Pilot Dimensions										Add Stroke				
		Style 2 CC	Style 1 & 3 KK	A	+.000 -.002 B	C	D	LAF	NA	RD (Max.)	RT	VF	WF	XG	Min. XI♦♦	Y	XJ	ZB
7	3	2 3/4-12	2 1/4-12	3 1/2	3.749	1	2 5/8	5 3/4	2 7/8	5 7/16	7/8	5/16	2 1/4	3 5/8	6 9/16	3 3/4	9 3/8	12
	5	4 3/4-12	3 1/2-12	5	5.749	1	—	7 1/4	4 7/8	7 7/16	1 5/16	5/16	2 1/4	3 5/8	6 9/16	3 3/4	9 3/8	12
	3 1/2	3 1/4-12	2 1/2-12	3 1/2	4.249	1	3	5 3/4	3 3/8	5 15/16	1 5/16	5/16	2 1/4	3 5/8	6 9/16	3 3/4	9 3/8	12
	4	3 3/4-12	3-12	4	4.749	1	3 3/8	6 1/4	3 7/8	6 5/16	1 5/16	5/16	2 1/4	3 5/8	6 9/16	3 3/4	9 3/8	12
8	3 1/2	3 1/4-12	2 1/2-12	3 1/2	4.249	1	3	5 3/4	3 3/8	5 15/16	1 5/16	5/16	2 1/4	3 3/4	7 1/16	3 7/8	10 1/4	13 1/4
	5 1/2	5 1/4-12	4-12	5 1/2	6.249	1	—	7 3/4	5 3/8	7 15/16	1 5/16	5/16	2 1/4	3 3/4	7 1/16	3 7/8	10 1/4	13 1/4
	4	3 3/4-12	3-12	4	4.749	1	3 3/8	6 1/4	3 7/8	6 5/16	1 5/16	5/16	2 1/4	3 3/4	7 1/16	3 7/8	10 1/4	13 1/4
	5	4 3/4-12	3 1/2-12	5	5.749	1	—	7 1/4	4 7/8	7 7/16	1 5/16	5/16	2 1/4	3 3/4	7 1/16	3 7/8	10 1/4	13 1/4

♦♦ Dimension XI to be specified by customer.

**Table 3 —
Envelope and
Mounting Dimensions**

Bore	Rod Dia. MM	Thread	Style 2 CC	Style 1 & 3 KK	A	+.000 -.002 B	C	D	LAF	NA	RD (Max.)	RT	VF	WF	XG	Min. XI♦♦	Y	Add Stroke	
																		XJ	ZB
7	3	2 3/4-12	2 1/4-12	3 1/2	3.749	1	2 5/8	5 3/4	2 7/8	5 7/16	7/8	5/16	2 1/4	3 5/8	6 9/16	3 3/4	9 3/8	12	
7	5	4 3/4-12	3 1/2-12	5	5.749	1	—	7 1/4	4 7/8	7 7/16	1 5/16	5/16	2 1/4	3 5/8	6 9/16	3 3/4	9 3/8	12	
7	3 1/2	3 1/4-12	2 1/2-12	3 1/2	4.249	1	3	5 3/4	3 3/8	5 15/16	1 5/16	5/16	2 1/4	3 5/8	6 9/16	3 3/4	9 3/8	12	
7	4	3 3/4-12	3-12	4	4.749	1	3 3/8	6 1/4	3 7/8	6 5/16	1 5/16	5/16	2 1/4	3 5/8	6 9/16	3 3/4	9 3/8	12	
8	3 1/2	3 1/4-12	2 1/2-12	3 1/2	4.249	1	3	5 3/4	3 3/8	5 15/16	1 5/16	5/16	2 1/4	3 3/4	7 1/16	3 7/8	10 1/4	13 1/4	
8	5 1/2	5 1/4-12	4-12	5 1/2	6.249	1	—	7 3/4	5 3/8	7 15/16	1 5/16	5/16	2 1/4	3 3/4	7 1/16	3 7/8	10 1/4	13 1/4	
8	4	3 3/4-12	3-12	4	4.749	1	3 3/8	6 1/4	3 7/8	6 5/16	1 5/16	5/16	2 1/4	3 3/4	7 1/16	3 7/8	10 1/4	13 1/4	
8	5	4 3/4-12	3 1/2-12	5	5.749	1	—	7 1/4	4 7/8	7 7/16	1 5/16	5/16	2 1/4	3 3/4	7 1/16	3 7/8	10 1/4	13 1/4	

How to Use Double Rod Cylinder Dimension Drawings

To determine dimensions for a double rod cylinder, first refer to the desired single rod mounting style cylinder shown on preceding pages of this catalog. After selecting necessary dimensions from that drawing return to this page, supplement the single rod dimensions with those shown on drawing and dimension table. Note that double rod cylinders have a head (Dim. G) at both ends and that dimension LD replaces LG. The double rod dimensions differ from, or are in addition to, those for single rod cylinders shown on preceding pages and provide the information needed to completely dimension a double rod cylinder.

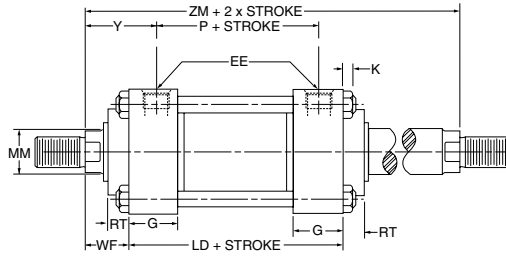

On a double rod cylinder where the two rod ends are different, be sure to clearly state which rod end is to be assembled at which end. Port position 1 is standard. If other than standard, specify pos. 2, 3 or 4 when viewed from one end only.

Bore	Rod Dia. MM	Add Stroke			Add 2X Stroke
		LD	Style FS SN	Style SL SS	ZM
1 1/2	5/8	47/8	27/8	41/8	67/8
2	1	47/8	27/8	37/8	75/8
2 1/2	1	5	3	35/8	73/4
3 1/4	1 3/8	5 3/4	3 1/2	43/8	9
4	1 3/4	6	3 3/4	41/4	9 3/4
5	2	6 1/2	4 1/4	43/4	10 1/2
6	2 1/2	7 3/8	47/8	5 1/8	11 7/8
7	3	8 1/2	5 3/8	5 3/4	13
8	3 1/2	9 1/2	6 1/8	6 3/4	14

All dimensions are in inches and apply to smallest rod sizes only. For alternate rod sizes, determine all envelope dimensions (within LD dim.) as described above and then use appropriate rod end dimensions for proper rod size from single rod cylinder.

Bolted & Full Plate Retainer Held Gland

Bore	Rod Dia.	NM2, BEF1, BEF2, ME6, SL, FS, TM1, TM2, PB2, TM3, SA	NM1, NM3, REF1, REF2	ME5
1 1/2	5/8	B	R	B
	1	R	R	B
2	1	B	R	B
	1 3/8	R	R	B
2 1/2	1	B	B	B
	1 3/8	B	B	B
	1 3/4	B	R	B
3 1/4	1 3/8	B	B	B
	1 3/4	B	B	B
4	2	B	B	B
	1 3/4	B	B	B
	2 1/2	B	B	B
5	2	B	B	B
	2 1/2	B	B	B
	3	B	B	B
	3 1/2	B	R	B
6	2 1/2	B	B	B
	3	B	B	B
	3 1/2	B	B	B
7	4	B	B	B
	3	B	B	B
	3 1/2	B	B	B
8	5	B	B	B
	4	B	B	B
	5 1/2	B	B	B
	3 1/2	B	B	B

The chart at the left specifies the gland retainer construction – Bolted Retainer or Full Face Retainer – that will be supplied based on the bore, rod diameter and mounting combination selected in the cylinder model number.

Rod Bearing Construction
B = Bolted Gland
R = Retainer Held Gland

NOTES

Series H Large Bore High Pressure Hydraulic Cylinders

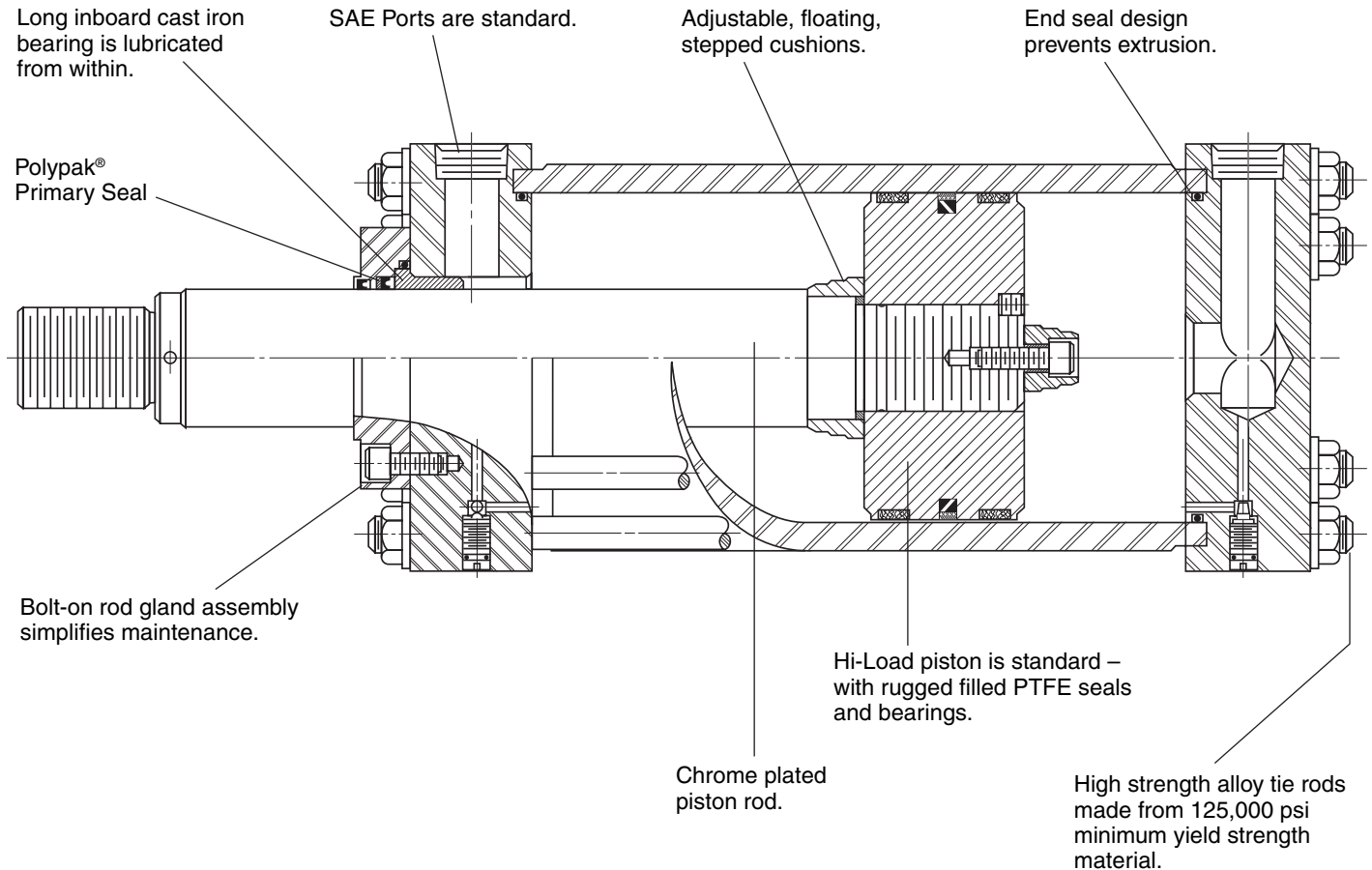

Standard Specifications

- Heavy Duty Service
- Standard Construction – Square Head – Tie Rod Design
- Nominal Pressure – 3000 PSI*
- Standard Fluid – Hydraulic Oil
- Standard Temperature – -10°F. to +165°F.**
- Bore Sizes – 10" through 20" (Larger sizes available)

In line with our policy of continuing product improvement, specifications in this catalog are subject to change.

- Piston Rod Diameter – 4½" through 10"
- Mounting Styles – Twelve standard styles at various application ratings
- Strokes – Available in any practical stroke length
- Cushions – Optional at either end or both ends of stroke
- Rod Ends – Two Standard Choices – Specials to Order

*If hydraulic operating pressure exceeds 3000 PSI, send application data for engineering evaluation and recommendation. See [page 58](#) for actual design factors.

** See [page 57](#) for higher temperature service.

Series H
Large Bore
High Pressure Hydraulic Cylinders

Available Mounting Styles

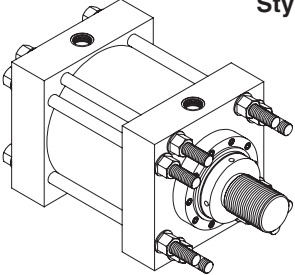
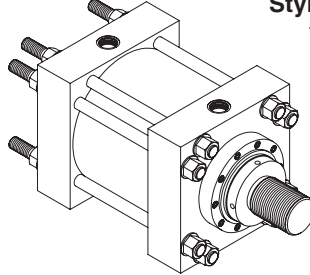
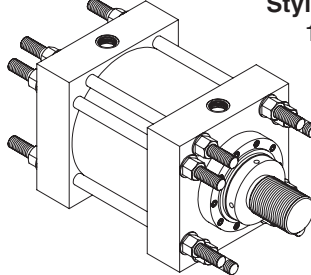
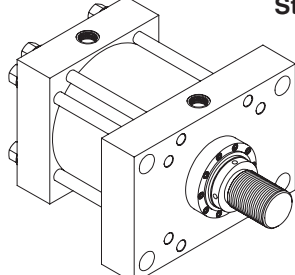
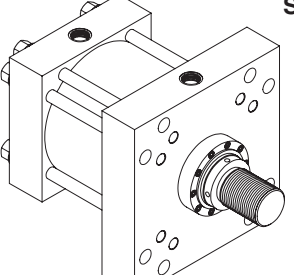
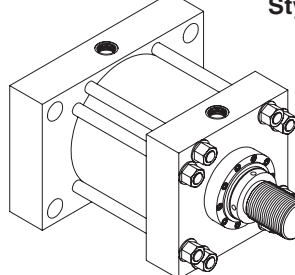
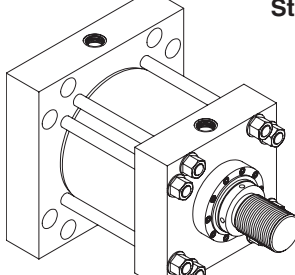
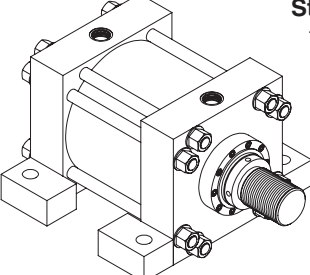
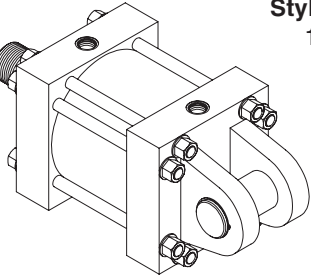
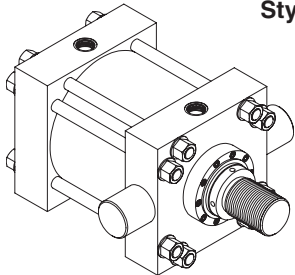
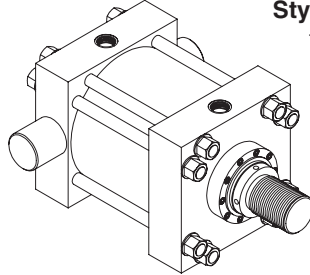
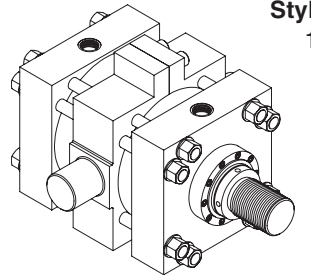
<p>Tie Rods Extended Head End</p>  <p>Style NM3 10"-14"</p> <p>(NFPA MX3)</p>	<p>Tie Rods Extended Cap End</p>  <p>Style NM2 10"-14"</p> <p>(NFPA MX2)</p>	<p>Tie Rods Extended Both Ends</p>  <p>Style NM1 10"-14"</p> <p>(NFPA MX1)</p>
<p>Head Rectangular</p>  <p>Style ME5 10"-20"</p> <p>(NFPA ME5)</p>	<p>Head Square Flange</p>  <p>Style IH3 10"-20"</p> <p>(NFPA MF5)</p>	<p>Cap Rectangular</p>  <p>Style ME6 10"-20"</p> <p>(NFPA ME6)</p>
<p>Cap Square Flange</p>  <p>Style IH4 10"-20"</p> <p>(NFPA MF6)</p>	<p>Side Lug</p>  <p>Style SL 10"-14"</p> <p>(NFPA MS2)</p>	<p>Cap Fixed Clevis</p>  <p>Style PB2 10"-20"</p> <p>(NFPA MP1)</p>
<p>Head Trunnion</p>  <p>Style TM1 10"-14"</p> <p>(NFPA MT1)</p>	<p>Cap Trunnion</p>  <p>Style TM2 10"-14"</p> <p>(NFPA MT2)</p>	<p>Intermediate Fixed Trunnion</p>  <p>Style TM3 10"-20"</p> <p>(NFPA MT4)</p>

Tie Rods Extended Head End
Style NM3
(NFPA Style MX3)

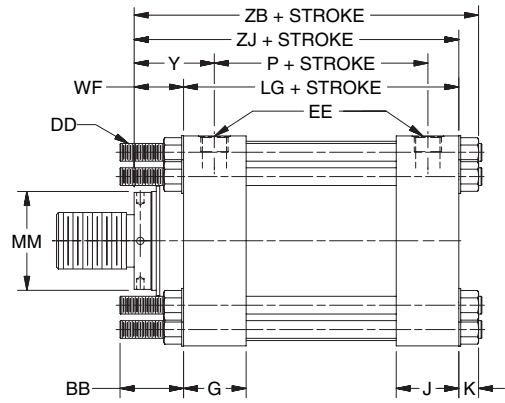
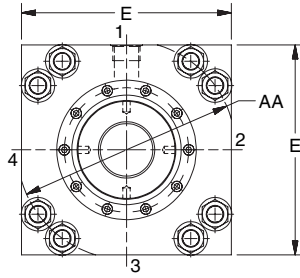
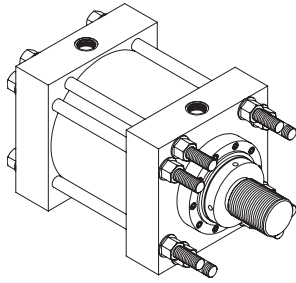

Tie Rods Extended Cap End
Style NM2
(NFPA Style MX2)

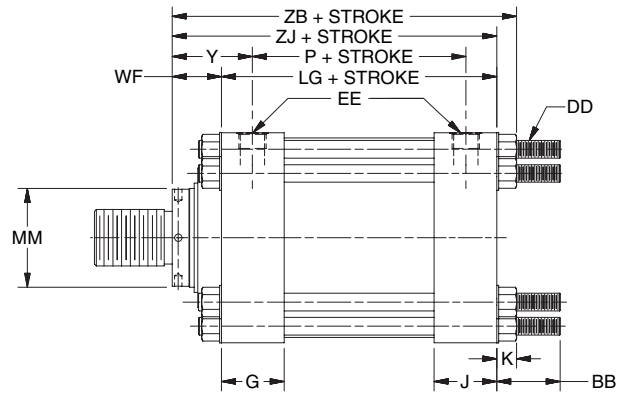
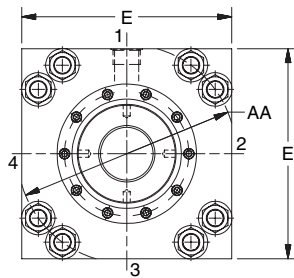
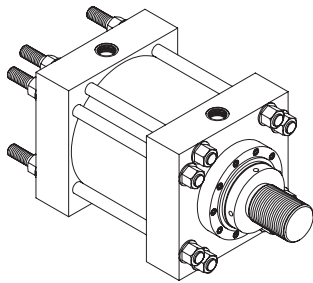

Tie Rods Extended Both Ends
Style NM1
(NFPA Style MX1)

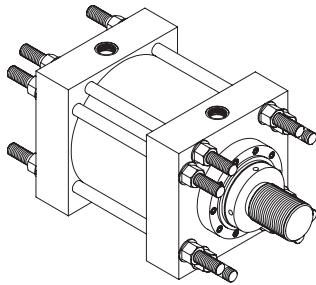

Basic Mounting (NM0) — Not shown is no tie rod extended and can be supplied upon request.

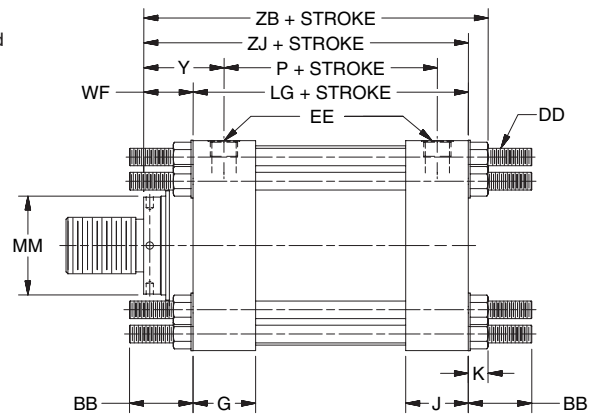
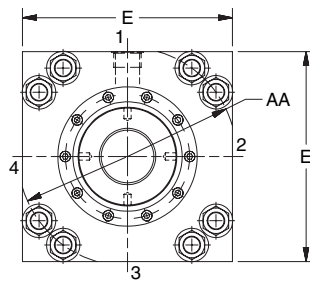

Rod End Dimensions — see Table 2

Thread Style 1
(NFPA Style SM)
Small Male

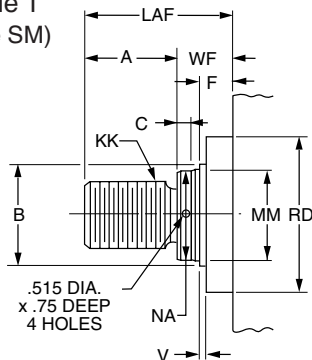

Thread Style 3
(NFPA Style SF)
Small Female

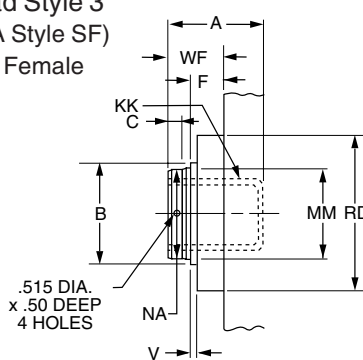

Special Thread Style 4

Special thread, extension, rod eye, blank, etc., are also available.

To order, specify "Style 4" and give desired dimensions for KK, A and WF. If otherwise special, furnish dimensional sketch.

If rod end is not specified, Style 1 will be furnished.

Use Style 3 for applications where female rod ends are required.

Table 1—Envelope and Mounting Dimensions

Bore	AA	BB	DD	E	EE* NPTF	EEf▲ S.A.E. FLANGE PORT	EE** S.A.E. STRAIGHT THREAD	G	J	K	RA	RB	RC	RR	Add Stroke	
															LG	P
10	13.00	4 1/8	1 1/8-12	12 5/8	2	2	24	3 11/16	3 11/16	1 9/32	5.291	3.775	–	2 1/8	12 1/8	8 1/2
12	15.50	4 1/2	1 1/4-12	14 7/8	2 1/2	2 1/2	24	4 7/16	4 7/16	1 13/32	6.270	4.555	–	2 3/8	14 1/2	10 1/8
14	17.38	4 1/2	1 1/4-12	17 1/8	2 1/2	2 1/2	24	4 7/8	4 7/8	1 13/32	7.485	6.143	4.409	2 1/4	15 5/8	10 7/8

* NPTF ports are available at no extra charge.

▲ Optional SAE flange ports may be specified – flange to be supplied by customer. See Table 4 for flange port pattern dimensions.

** SAE straight thread ports are standard and are indicated by port number.

Table 2—Rod Dimensions

Bore	Rod Dia. MM	Thread KK	Rod Extensions and Pilot Dimensions										Add Stroke		
			A	+0.000 -.005 B	C	F	LAF	NA	RD	V	WF	Y	ZB	ZJ	
10	4 1/2	3 1/4-12	4 1/2	5.249	1	1 15/16	7 7/16	4 3/8	8 1/4	1/4	2 15/16	4 3/4	16 11/32	15 1/16	
	7	5-12	7	7.999	1	1 15/16	10 1/2	6 7/8	10 1/2	3/8	3 1/2	5 5/16	16 29/32	15 5/8	
	5	3 1/2-12	5	5.749	1	1 15/16	8 3/16	4 7/8	8 7/8	1/4	3 3/16	5	16 19/32	15 5/16	
	5 1/2	4-12	5 1/2	6.249	1	1 15/16	8 11/16	5 3/8	9 3/8	1/4	3 3/16	5	16 19/32	15 5/16	
12	5 1/2	4-12	5 1/2	6.249	1	1 15/16	8 11/16	5 3/8	9 3/8	1/4	3 3/16	5 3/8	19 3/32	17 11/16	
	8	5 3/4-12	8	8.999	1	1 15/16	12	7 7/8	12 1/2	3/8	4	6 3/16	19 29/32	18 1/2	
	7	5-12	7	7.999	1	1 15/16	10 1/2	6 7/8	10 1/2	3/8	3 1/2	5 11/16	19 13/32	18	
14	7	5-12	7	7.999	1	1 15/16	10 1/2	6 7/8	10 1/2	3/8	3 1/2	5 7/8	20 17/32	19 1/8	
	10	7 1/4-12	10	10.999	1	1 15/16	14 1/2	9 7/8	14 1/2	3/8	4 1/2	6 7/8	21 17/32	20 1/8	
	8	5 3/4-12	8	8.999	1	1 15/16	12	7 7/8	12 1/2	3/8	4	6 3/8	21 1/32	19 5/8	

Table 3 — Envelope and Mounting Dimensions

Table 4—Optional SAE Flange Port Pattern

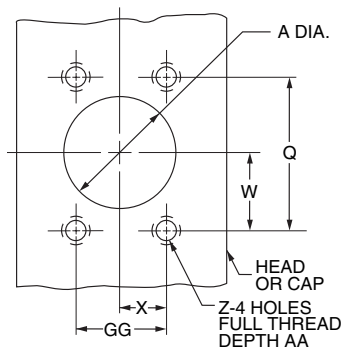

Nom. Flange Size	S.A.E. Flange Dash Size	A	Q	GG	W	X	Z-THD UNC-2B	AA Min.
1 1/2	-24	1.50	2.750	1.406	1.38	0.70	1/2-13	1.06
2	-32	2.00	3.062	1.688	1.53	0.84	1/2-13	1.06
2 1/2	-40	2.50	3.500	2.000	1.75	1.00	1/2-13	1.19
3	-48	3.00	4.188	2.438	2.09	1.22	5/8-11	1.19

Table 5—Tie Rod Information see Table 1 for dimensions

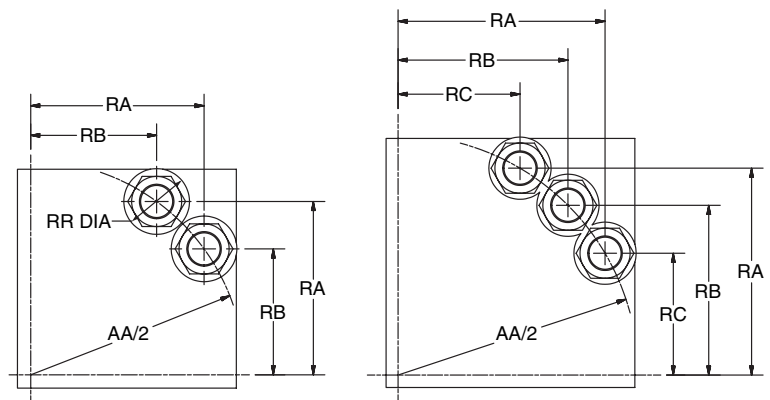

10", 12" Bores, 8 Tie Rods

14" Bores, 12 Tie Rods

Head Rectangular Mounting
Style ME5 (10"-14" Bore)
(NFPA Style ME5)

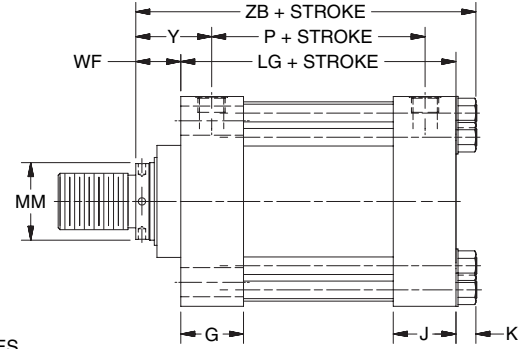
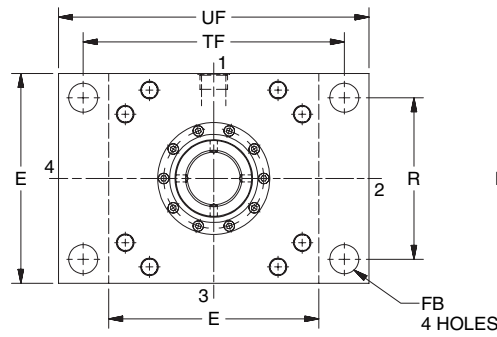
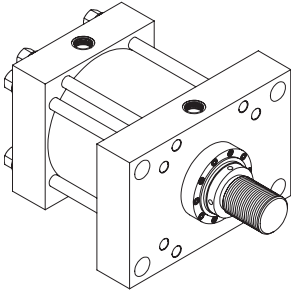

Head Rectangular Mounting
Style ME5 (16"-20" Bore)
(NFPA Style ME5)

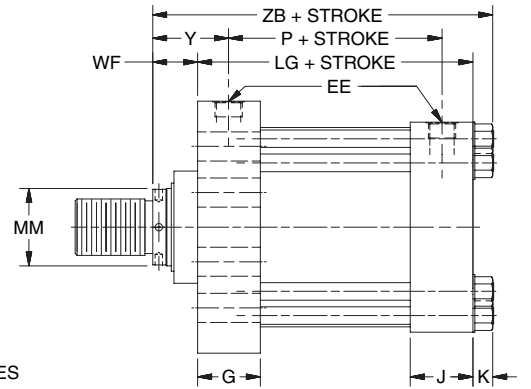
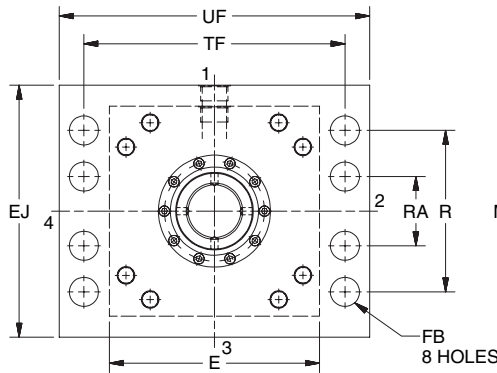
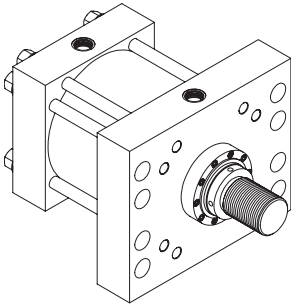

Head Square Flange Mounting
Style IH3
(NFPA Style MF5)

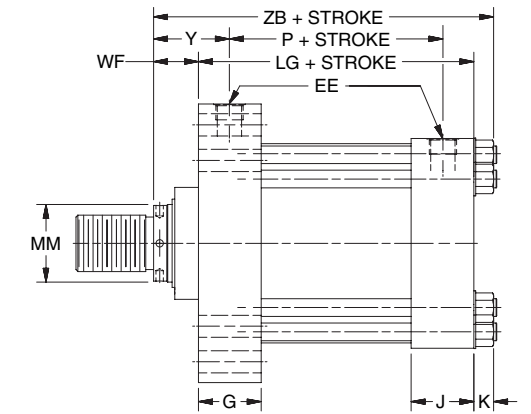
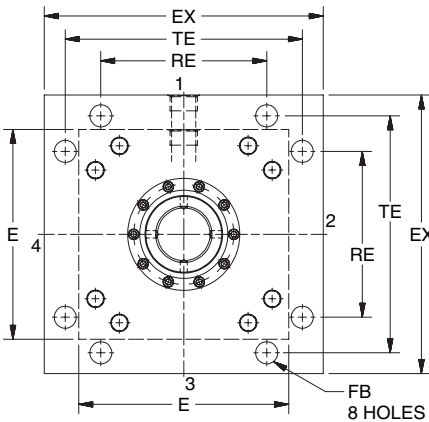
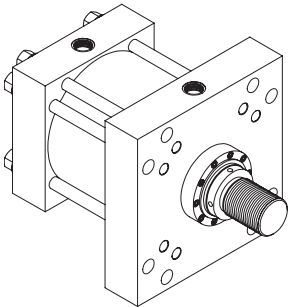

Rod End Dimensions — see Table 2

Thread Style 1
(NFPA Style SM)
Small Male

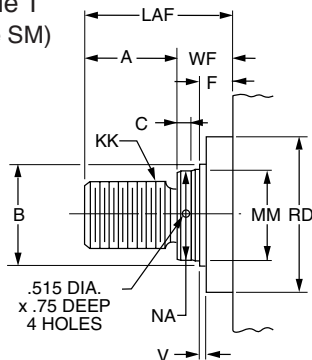

Thread Style 3
(NFPA Style SF)
Small Female

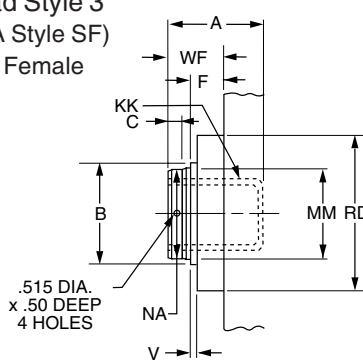

Special Thread Style 4

Special thread, extension, rod eye, blank, etc., are also available.

To order, specify "Style 4" and give desired dimensions for KK, A and WF. If otherwise special, furnish dimensional sketch.

If rod end is not specified, Style 1 will be furnished.

Use Style 3 for applications where female rod ends are required.

Table 1—Envelope and Mounting Dimensions

Bore	E	EB	EE* NPTF	EEf▲ S.A.E. FLANGE PORT	EE** S.A.E. STRAIGHT THREAD	EX	FB	G	J	K	R	RE	TE	TF	UF	Add Stroke	
																LG	P
10	12 ⁵ / ₈	1 ⁵ / ₁₆	2	2	24	16 ⁵ / ₈	11 ³ / ₁₆	31 ¹ / ₁₆	31 ¹ / ₁₆	1 ⁹ / ₃₂	9.62	9.89	14.13	15 ⁷ / ₈	19	12 ¹ / ₈	8 ¹ / ₂
12	14 ⁷ / ₈	1 ⁹ / ₁₆	2 ¹ / ₂	2 ¹ / ₂	24	19 ³ / ₄	2 ¹ / ₁₆	4 ⁷ / ₁₆	4 ⁷ / ₁₆	11 ³ / ₃₂	11.45	11.75	16.79	18 ¹ / ₂	22	14 ¹ / ₂	10 ¹ / ₈
14	17 ¹ / ₈	1 ¹³ / ₁₆	2 ¹ / ₂	2 ¹ / ₂	24	21 ³ / ₄	2 ⁵ / ₁₆	4 ⁷ / ₈	4 ⁷ / ₈	11 ³ / ₃₂	13.26	12.90	18.43	21	25	15 ⁵ / ₈	10 ⁷ / ₈

Table 1A—Envelope and Mounting Dimensions

Bore	E	EB	EE (SAE)	EE (FLANGE)	EJ	EX	FB	G	J	K	R	RA	RE	TE	TF	UF	Add Stroke	
																	LG	P
16	19	1 ¹³ / ₁₆	24	3	20	24 ¹ / ₂	1 ¹³ / ₁₆	5 ⁷ / ₈	5 ⁷ / ₈	1 ²⁹ / ₃₂	15 ¹ / ₂	8	15.28	21.03	21	24 ¹ / ₂	18 ¹ / ₈	12 ¹ / ₈
18	22	2 ¹ / ₁₆	24	3	23	26 ¹ / ₂	2 ¹ / ₁₆	6 ⁷ / ₈	6 ⁷ / ₈	1 ²⁹ / ₃₂	18	7 ¹ / ₄	16.45	22.65	24 ¹ / ₄	28 ¹ / ₄	21 ¹ / ₈	15 ¹ / ₈
20	24	2 ¹ / ₁₆	24	3	25	29	2 ¹ / ₁₆	7 ⁷ / ₈	7 ⁷ / ₈	1 ²⁹ / ₃₂	20	8	18.07	24.87	26 ¹ / ₂	30 ¹ / ₂	23 ⁵ / ₈	17 ⁵ / ₈

* NPTF ports are available at no extra charge.

▲ Optional SAE flange ports may be specified – flange to be supplied by customer. See Table 4 for flange port pattern dimensions.

** SAE straight thread ports are standard and are indicated by port number.

Table 2—Rod Dimensions

Bore	Rod Dia. MM	Thread KK	Rod Extensions and Pilot Dimensions										Add Stroke	
			A	+0.000 -0.005 B	C	F	LAF	NA	RD	V	WF	Y	ZB	
10	4 ¹ / ₂	3 ¹ / ₄ -12	4 ¹ / ₂	5.249	1	1 ¹⁵ / ₁₆	7 ⁷ / ₁₆	4 ³ / ₈	8 ¹ / ₄	1 ¹ / ₄	2 ¹⁵ / ₁₆	4 ³ / ₄	16 ¹¹ / ₃₂	
	7	5-12	7	7.999	1	1 ¹⁵ / ₁₆	10 ¹ / ₂	6 ⁷ / ₈	10 ¹ / ₂	3 ¹ / ₈	3 ¹ / ₂	5 ⁵ / ₁₆	16 ²⁹ / ₃₂	
	5	3 ¹ / ₂ -12	5	5.749	1	1 ¹⁵ / ₁₆	8 ³ / ₁₆	4 ⁷ / ₈	8 ⁷ / ₈	1 ¹ / ₄	3 ³ / ₁₆	5	16 ¹⁹ / ₃₂	
	5 ¹ / ₂	4-12	5 ¹ / ₂	6.249	1	1 ¹⁵ / ₁₆	8 ¹¹ / ₁₆	5 ³ / ₈	9 ³ / ₈	1 ¹ / ₄	3 ³ / ₁₆	5	16 ¹⁹ / ₃₂	
12	5 ¹ / ₂	4-12	5 ¹ / ₂	6.249	1	1 ¹⁵ / ₁₆	8 ¹¹ / ₁₆	5 ³ / ₈	9 ³ / ₈	1 ¹ / ₄	3 ³ / ₁₆	5 ³ / ₈	19 ³ / ₃₂	
	8	5 ³ / ₄ -12	8	8.999	1	1 ¹⁵ / ₁₆	12	7 ⁷ / ₈	12 ¹ / ₂	3 ¹ / ₈	4	6 ³ / ₁₆	19 ²⁹ / ₃₂	
14	7	5-12	7	7.999	1	1 ¹⁵ / ₁₆	10 ¹ / ₂	6 ⁷ / ₈	10 ¹ / ₂	3 ¹ / ₈	3 ¹ / ₂	5 ⁷ / ₈	20 ¹⁷ / ₃₂	
	10	7 ¹ / ₄ -12	10	10.999	1	1 ¹⁵ / ₁₆	14 ¹ / ₂	9 ⁷ / ₈	14 ¹ / ₂	3 ¹ / ₈	4 ¹ / ₂	6 ⁷ / ₈	21 ¹⁷ / ₃₂	
	8	5 ³ / ₄ -12	8	8.999	1	1 ¹⁵ / ₁₆	12	7 ⁷ / ₈	12 ¹ / ₂	3 ¹ / ₈	4	6 ³ / ₈	21 ¹ / ₃₂	
16	8	5 ³ / ₄ -12	8	8.999	1	1 ¹⁵ / ₁₆	12	7 ⁷ / ₈	12 ¹ / ₂	3 ¹ / ₈	4	7	24 ¹ / ₃₂	
	9	6 ¹ / ₂ -12	9	9.999	1	1 ¹⁵ / ₁₆	13 ¹ / ₄	8 ⁷ / ₈	13 ¹ / ₂	3 ¹ / ₈	4 ¹ / ₄	7 ¹ / ₄	24 ⁹ / ₃₂	
18	10	7 ¹ / ₄ -12	10	10.999	1	1 ¹⁵ / ₁₆	14 ¹ / ₂	9 ⁷ / ₈	14 ¹ / ₂	3 ¹ / ₈	4 ¹ / ₂	7 ¹ / ₂	24 ¹⁷ / ₃₂	
	9	6 ¹ / ₂ -12	9	9.999	1	1 ¹⁵ / ₁₆	13 ¹ / ₄	8 ⁷ / ₈	13 ¹ / ₂	3 ¹ / ₈	4 ¹ / ₄	7 ¹ / ₄	27 ⁹ / ₃₂	
20	10	7 ¹ / ₄ -12	10	10.999	1	1 ¹⁵ / ₁₆	14 ¹ / ₂	9 ⁷ / ₈	14 ¹ / ₂	3 ¹ / ₈	4 ¹ / ₂	7 ¹ / ₂	27 ¹⁷ / ₃₂	

Table 3—Envelope and Mounting Dimensions

Table 4—Optional SAE Flange Port Pattern

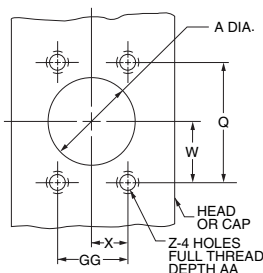

Nom. Flange Size	S.A.E. Flange Dash Size	A	Q	GG	W	X	Z-THD UNC-2B	AA Min.
1 ¹ / ₂	-24	1.50	2.750	1.406	1.38	0.70	1/2-13	1.06
2	-32	2.00	3.062	1.688	1.53	0.84	1/2-13	1.06
2 ¹ / ₂	-40	2.50	3.500	2.000	1.75	1.00	1/2-13	1.19
3	-48	3.00	4.188	2.438	2.09	1.22	5/8-11	1.19

Table 5—Tie Rod Information

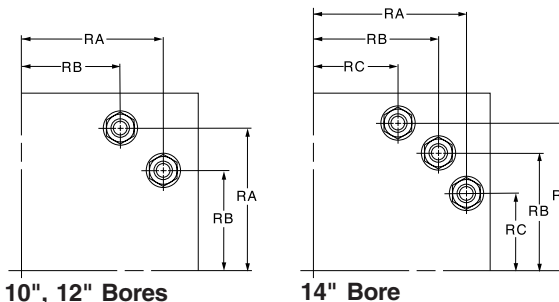

Bore	10	12	14	16	18	20
Tie Rod Thread	1 ¹ / ₈ -12	1 ¹ / ₄ -12	1 ¹ / ₄ -12	*	*	*
RA	5.291	6.270	7.485	*	*	*
RB	3.775	4.555	6.143	*	*	*
RC	—	—	4.409	*	*	*

*Consult factory for dimensions

Cap Rectangular Mountings

Style ME6 (10"-14" Bore)
(NFPA Style ME6)

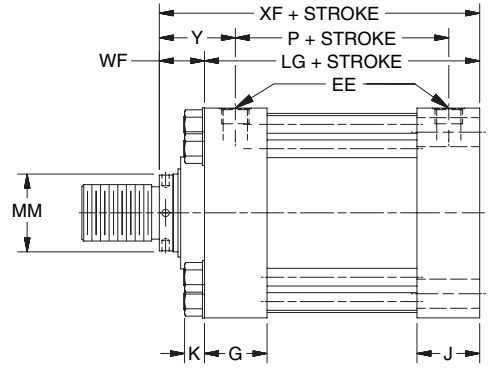
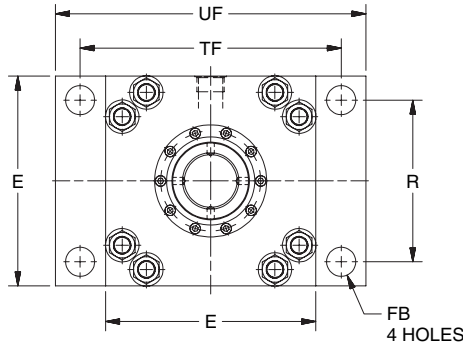
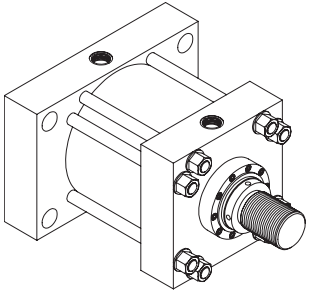

Cap Rectangular Mountings

Style ME6 (16"-20" Bore)
(NFPA Style ME6)

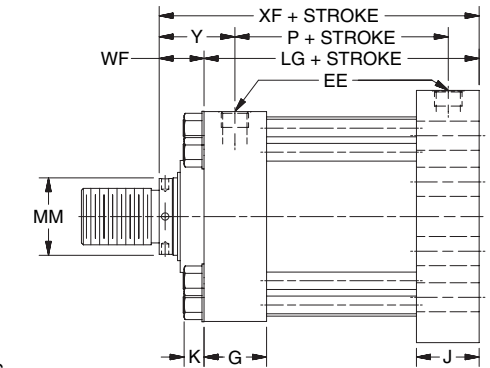
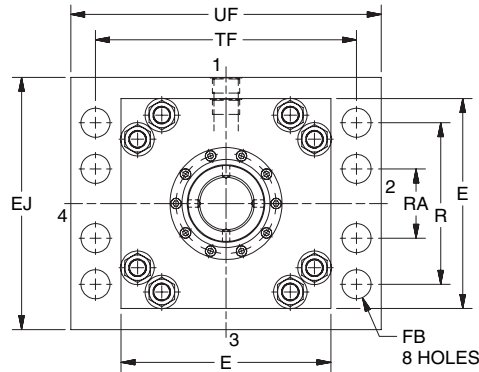
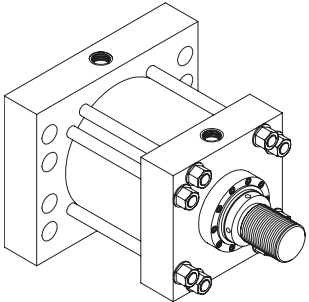

Cap Square Flange Mounting

Style IH4
(NFPA Style MF6)

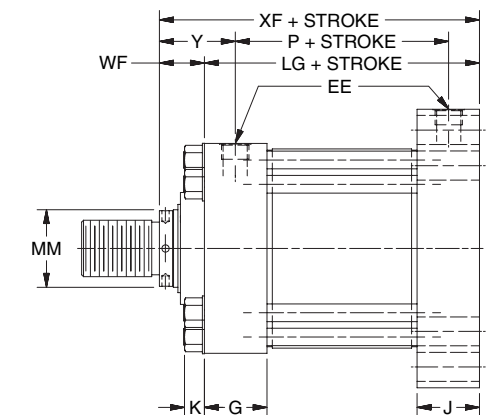
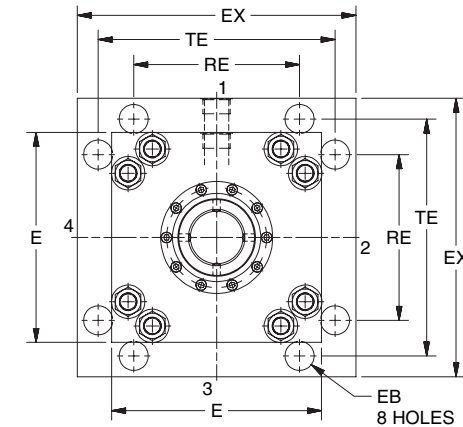
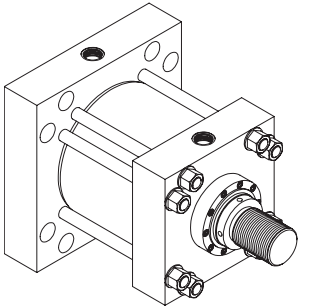

Side Lugs Mounting

Style SL
10"-14" Bore only
(NFPA Style MS2)

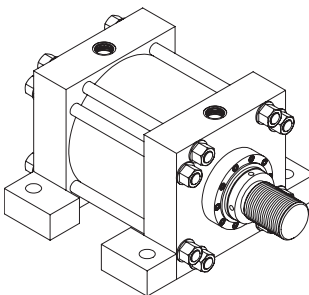

Note: Stroke lengths on lug mounted cylinders should not be shorter than the cylinder bore diameter. Consult factory for recommendations on shorter stroke lengths.

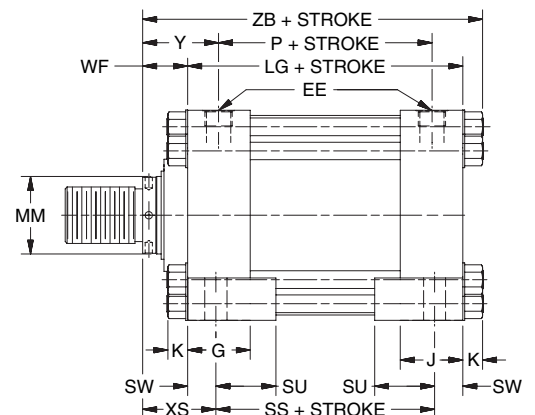
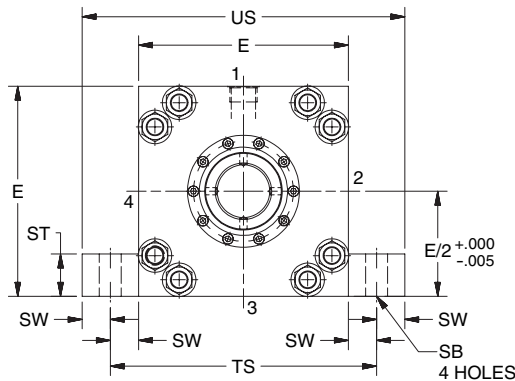

Rod End Dimensions — see Table 2

Thread Style 1
(NFA Style SM)
Small Male

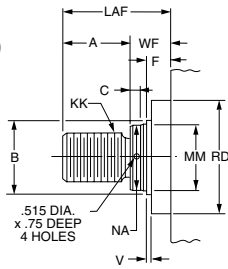

If rod end is not specified, Style 1 will be furnished.

Thread Style 3
(NFA Style SF)
Small Female

Use Style 3 for applications where female rod ends are required.

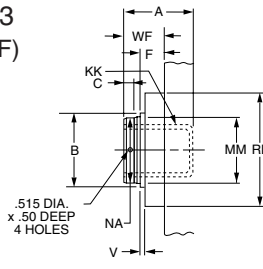

Special Thread Style 4

Special thread, extension, rod eye, blank, etc., are also available.

To order, specify "Style 4" and give desired dimensions for KK, A and WF. If otherwise special, furnish dimensional sketch.

Table 1—Envelope and Mounting Dimensions

Bore	E	EB	EE* NPTF	EE† S.A.E. FLANGE PORT	EE** S.A.E. STRAIGHT THREAD	EX	FB	G	J	K	R	RE	SB	ST	SU	SW	TE	TF	TS	UF	US	Add Stroke		
																						LG	P	SS
10	12 ⁵ / ₈	15 ¹ / ₁₆	2	2	24	16 ⁵ / ₈	11 ³ / ₁₆	3 ¹ / ₁₆	3 ¹ / ₁₆	19 ¹ / ₃₂	9.62	9.89	19 ¹ / ₁₆	2 ¹ / ₄	3 ¹ / ₂	1 ⁵ / ₈	14.13	15 ⁷ / ₈	15 ⁷ / ₈	19	19 ¹ / ₈	12 ¹ / ₈	8 ¹ / ₂	8 ⁷ / ₈
12	14 ⁷ / ₈	19 ¹ / ₁₆	2 ¹ / ₂	2 ¹ / ₂	24	19 ³ / ₄	2 ¹ / ₁₆	4 ⁷ / ₁₆	4 ⁷ / ₁₆	11 ³ / ₃₂	11.45	11.75	19 ¹ / ₁₆	3	4 ¹ / ₄	2	16.79	18 ¹ / ₂	18 ⁷ / ₈	22	22 ⁷ / ₈	14 ¹ / ₂	10 ¹ / ₈	10 ¹ / ₂
14	17 ¹ / ₈	11 ³ / ₁₆	2 ¹ / ₂	2 ¹ / ₂	24	21 ³ / ₄	2 ⁵ / ₁₆	4 ⁷ / ₈	4 ⁷ / ₈	11 ³ / ₃₂	13.26	12.90	2 ⁵ / ₁₆	4	4 ³ / ₄	2 ¹ / ₄	18.43	21	21 ⁵ / ₈	25	26 ¹ / ₈	15 ⁵ / ₈	10 ⁷ / ₈	11 ¹ / ₈

Table 1A—Envelope and Mounting Dimensions

Bore	E	EB	EE (SAE)	EE (FLANGE)	EJ	EX	FB	G	J	K	R	RA	RE	TE	TF	UF	Add Stroke	
																	LG	P
16	19	11 ³ / ₁₆	24	3	20	24 ¹ / ₂	11 ³ / ₁₆	5 ⁷ / ₈	5 ⁷ / ₈	1 ²⁹ / ₃₂	15 ¹ / ₂	8	15.28	21.03	21	24 ¹ / ₂	18 ¹ / ₈	12 ¹ / ₈
18	22	2 ¹ / ₁₆	24	3	23	26 ¹ / ₂	2 ¹ / ₁₆	6 ⁷ / ₈	6 ⁷ / ₈	1 ²⁹ / ₃₂	18	7 ¹ / ₄	16.45	22.65	24 ¹ / ₄	28 ¹ / ₄	21 ¹ / ₈	15 ¹ / ₈
20	24	2 ¹ / ₁₆	24	3	25	29	2 ¹ / ₁₆	7 ⁷ / ₈	7 ⁷ / ₈	1 ²⁹ / ₃₂	20	8	18.07	24.87	26 ¹ / ₂	30 ¹ / ₂	23 ⁵ / ₈	17 ⁵ / ₈

* NPTF ports are available at no extra charge.
 † Optional SAE flange ports may be specified – flange to be supplied by customer. See Table 4 for flange port pattern dimensions.
 ** SAE straight thread ports are standard and are indicated by port number.

Table 2—Rod Dimensions

Bore	Rod Dia. MM	Thread KK	Rod Extensions and Pilot Dimensions													Add Stroke	
			A	+0.000 -0.005 B	C	F	LAF	NA	RD	V	WF	Y	XS	XF	ZB		
10	4 ¹ / ₂	3 ¹ / ₄ -12	4 ¹ / ₂	5.249	1	1 ¹⁵ / ₁₆	7 ⁷ / ₁₆	4 ³ / ₈	8 ¹ / ₄	1 ¹ / ₄	2 ¹⁵ / ₁₆	4 ³ / ₄	4 ⁹ / ₁₆	15 ¹ / ₁₆	16 ¹¹ / ₃₂		
	7	5-12	7	7.999	1	1 ¹⁵ / ₁₆	10 ¹ / ₂	6 ⁷ / ₈	10 ¹ / ₂	3 ³ / ₈	3 ¹ / ₂	5 ⁵ / ₁₆	5 ¹ / ₈	15 ⁵ / ₈	16 ²⁹ / ₃₂		
	5	3 ¹ / ₂ -12	5	5.749	1	1 ¹⁵ / ₁₆	8 ³ / ₁₆	4 ⁷ / ₈	8 ⁷ / ₈	1 ¹ / ₄	3 ³ / ₁₆	5	4 ¹³ / ₁₆	15 ⁵ / ₁₆	16 ¹⁹ / ₃₂		
	5 ¹ / ₂	4-12	5 ¹ / ₂	6.249	1	1 ¹⁵ / ₁₆	8 ¹¹ / ₁₆	5 ³ / ₈	9 ³ / ₈	1 ¹ / ₄	3 ³ / ₁₆	5	4 ¹³ / ₁₆	15 ⁵ / ₁₆	16 ¹⁹ / ₃₂		
12	5 ¹ / ₂	4-12	5 ¹ / ₂	6.249	1	1 ¹⁵ / ₁₆	8 ¹¹ / ₁₆	5 ³ / ₈	9 ³ / ₈	1 ¹ / ₄	3 ³ / ₁₆	5 ³ / ₈	5 ³ / ₁₆	17 ¹¹ / ₁₆	19 ³ / ₃₂		
	8	5 ³ / ₄ -12	8	8.999	1	1 ¹⁵ / ₁₆	12	7 ⁷ / ₈	12 ¹ / ₂	3 ³ / ₈	4	6 ³ / ₁₆	6	18 ¹ / ₂	19 ²⁹ / ₃₂		
	7	5-12	7	7.999	1	1 ¹⁵ / ₁₆	10 ¹ / ₂	6 ⁷ / ₈	10 ¹ / ₂	3 ³ / ₈	3 ¹ / ₂	5 ¹¹ / ₁₆	5 ¹ / ₂	18	19 ¹³ / ₃₂		
14	7	5-12	7	7.999	1	1 ¹⁵ / ₁₆	10 ¹ / ₂	6 ⁷ / ₈	10 ¹ / ₂	3 ³ / ₈	3 ¹ / ₂	5 ⁷ / ₈	5 ³ / ₄	19 ¹ / ₈	20 ¹⁷ / ₃₂		
	10	7 ¹ / ₄ -12	10	10.999	1	1 ¹⁵ / ₁₆	14 ¹ / ₂	9 ⁷ / ₈	14 ¹ / ₂	3 ³ / ₈	4 ¹ / ₂	6 ⁷ / ₈	6 ³ / ₄	20 ¹ / ₈	21 ¹⁷ / ₃₂		
16	8	5 ³ / ₄ -12	8	8.999	1	1 ¹⁵ / ₁₆	12	7 ⁷ / ₈	12 ¹ / ₂	3 ³ / ₈	4	6 ³ / ₈	6 ¹ / ₄	19 ⁵ / ₈	21 ¹ / ₃₂		
	9	6 ¹ / ₂ -12	9	9.999	1	1 ¹⁵ / ₁₆	13 ¹ / ₄	8 ⁷ / ₈	13 ¹ / ₂	3 ³ / ₈	4 ¹ / ₄	7 ¹ / ₄	*	22 ¹ / ₈	*		
	10	7 ¹ / ₄ -12	10	10.999	1	1 ¹⁵ / ₁₆	14 ¹ / ₂	9 ⁷ / ₈	14 ¹ / ₂	3 ³ / ₈	4 ¹ / ₂	7 ¹ / ₂	*	22 ⁵ / ₈	*		
18	9	6 ¹ / ₂ -12	9	9.999	1	1 ¹⁵ / ₁₆	13 ¹ / ₄	8 ⁷ / ₈	13 ¹ / ₂	3 ³ / ₈	4 ¹ / ₄	7 ¹ / ₄	*	25 ³ / ₈	*		
	10	7 ¹ / ₄ -12	10	10.999	1	1 ¹⁵ / ₁₆	14 ¹ / ₂	9 ⁷ / ₈	14 ¹ / ₂	3 ³ / ₈	4 ¹ / ₂	7 ¹ / ₂	*	25 ⁵ / ₈	*		
20	10	7 ¹ / ₄ -12	10	10.999	1	1 ¹⁵ / ₁₆	14 ¹ / ₂	9 ⁷ / ₈	14 ¹ / ₂	3 ³ / ₈	4 ¹ / ₂	7 ¹ / ₂	*	28 ¹ / ₈	*		

*Consult Factory

Table 4—Optional SAE Flange Port Pattern

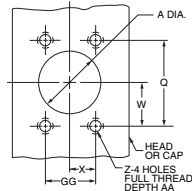

Nom. Flange Size	S.A.E. Flange Dash Size	A	Q	GG	W	X	Z-THD UNC-2B	AA Min.
1 ¹ / ₂	-24	1.50	2.750	1.406	1.38	0.70	1 ¹ / ₂ -13	1.06
2	-32	2.00	3.062	1.688	1.53	0.84	1 ¹ / ₂ -13	1.06
2 ¹ / ₂	-40	2.50	3.500	2.000	1.75	1.00	1 ¹ / ₂ -13	1.19
3	-48	3.00	4.188	2.438	2.09	1.22	5 ⁸ / ₁₁	1.19

Table 5—Tie Rod Information

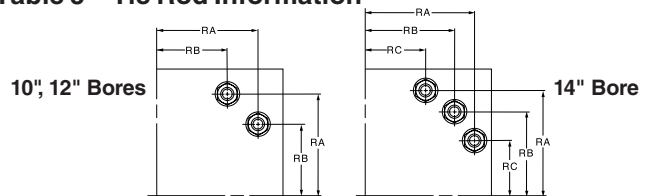

Bore	10	12	14	16	18	20
Tie Rod Thread	1 ¹ / ₈ -12	1 ¹ / ₄ -12	1 ¹ / ₄ -12	*	*	*
RA	5.291	6.270	7.485	*	*	*
RB	3.775	4.555	6.143	*	*	*
RC	—	—	4.409	*	*	*

*Consult factory for dimensions

Cap Fixed Clevis Mountings
Style PB2
(NFPA Style MP1)

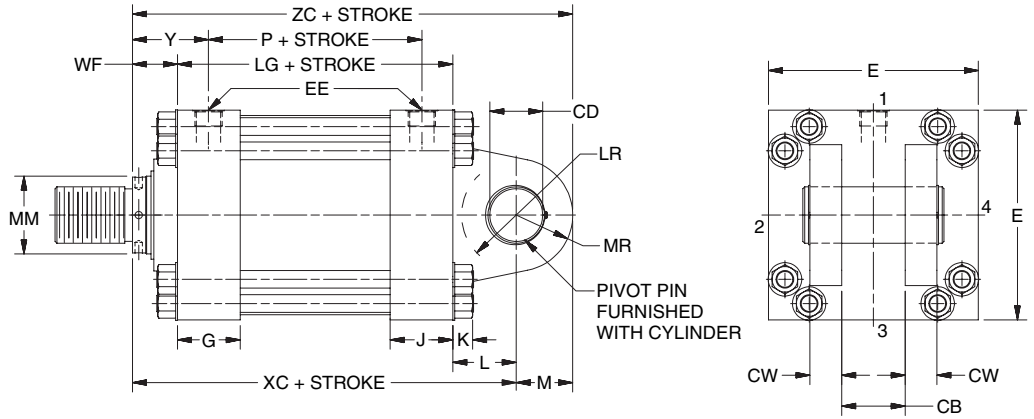
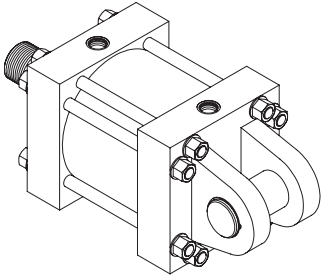

Head Trunnion Mounting
Style TM1
10"-14" Bore only
(NFPA Style MT1)

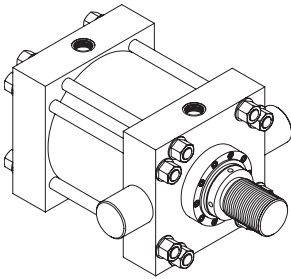

For Style TM1 Mount
Maximum
Pressure
Rating - PSI

Bore	PSI
10	1600
12	1500
14	1400

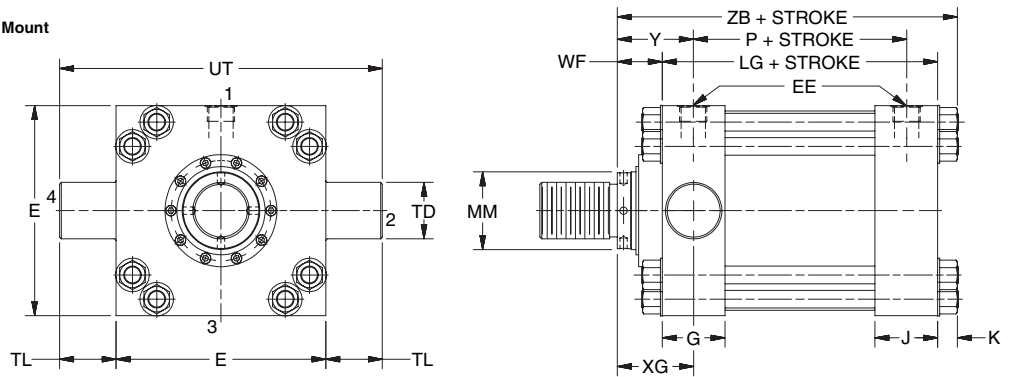

Cap Trunnion Mounting
Style TM2
10"-14" Bore only
(NFPA Style MT2)

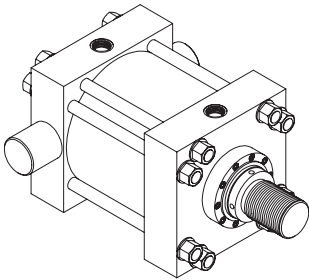

For Style TM2 Mount
Maximum
Pressure
Rating - PSI

Bore	PSI
10	1600
12	1500
14	1400

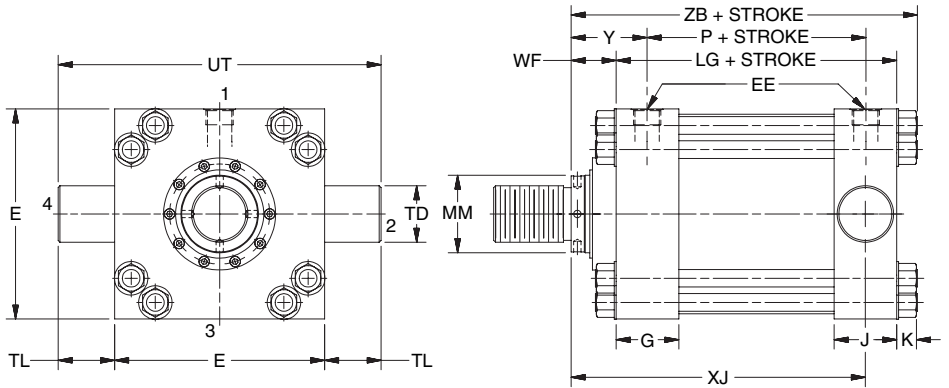

Intermediate Fixed Trunnion Mounting
Style TM3
(10"-14" Bore Only)
(NFPA Style MT4)

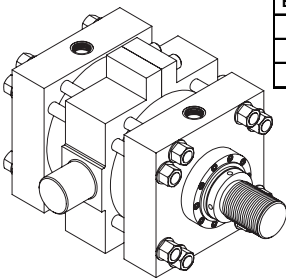

For Style TM3 Mount
Maximum
Pressure
Rating - PSI

Bore	PSI
10	1600
12	1500
14	1400

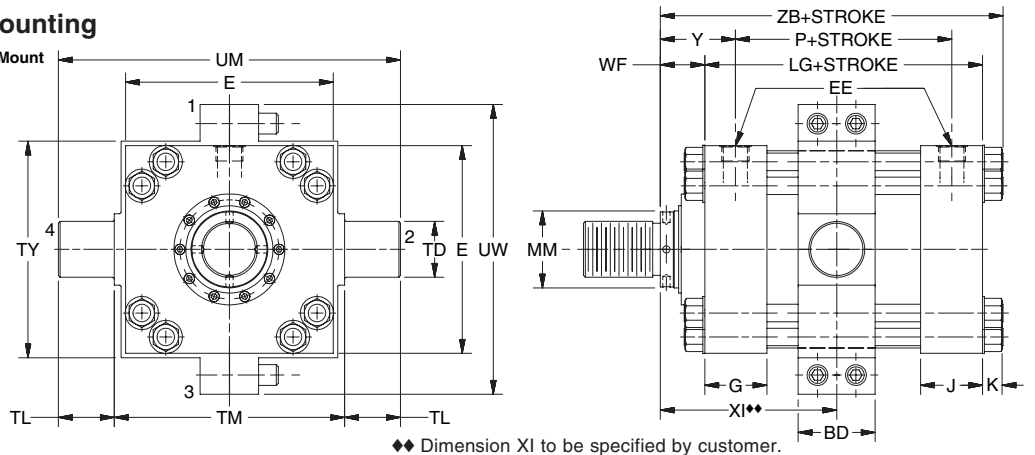

◆◆ Dimension XI to be specified by customer.

Rod End Dimensions — see Table 2

Thread Style 1
(NFWA Style SM)
Small Male

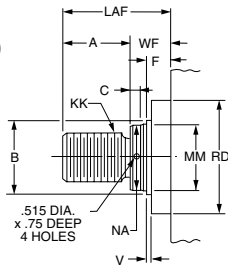

If rod end is not specified, Style 1 will be furnished.

Thread Style 3
(NFWA Style SF)
Small Female

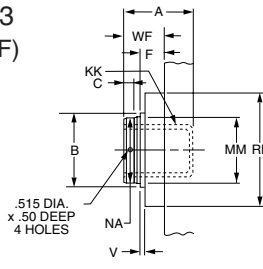

Use Style 3 for applications where female rod ends are required.

Special Thread Style 4

Special thread, extension, rod eye, blank, etc., are also available.

To order, specify "Style 4" and give desired dimensions for KK, A and WF. If otherwise special, furnish dimensional sketch.

Table 1—Envelope and Mounting Dimensions

Bore	BD	CB	+0.001 -0.003 CD	CW	E	EE* NPTF	EE† S.A.E. FLANGE PORT	EE** S.A.E. STRAIGHT THREAD	G	J	K	L	LR	M	MR	+0.000 -0.001 TD	TL	TM	TY	UM	UT	UW	LG	P	Add Stroke
10	4 1/2	4	3.500	2	12 5/8	2	2	24	3 11/16	3 11/16	1 9/32	4	3 3/8	3 1/2	3 1/2	3.500	3 1/2	14	13	21	19 5/8	17 1/2	12 1/8	8 1/2	
12	5 1/2	4 1/2	4.000	2 1/4	14 7/8	2 1/2	2 1/2	24	4 7/16	4 7/16	1 11/32	4 1/2	3 7/8	4	4	4.000	4	16 1/2	15 1/2	24 1/2	22 7/8	20 3/4	14 1/2	10 1/8	
14	5 1/2	6	5.000	3	17 1/8	2 1/2	2 1/2	24	4 7/8	4 7/8	1 11/32	5 3/4	4 3/16	5	5	4.500	4 1/2	19 1/2	19 1/4	28 1/2	26 1/8	24 3/4	15 5/8	10 7/8	

Table 1A—Envelope and Mounting Dimensions (Style PB2 only)

Bore	E	EE (SAE)	EE (FLANGE)	CB	CD	CW	G	J	K	L	LR	M	MD	MR	Add Stroke	
															LG	P
16	19	24	3	7	6	3 1/2	5 7/8	5 7/8	1 29/32	7	6 1/4	6	16	6	18 1/8	12 1/8
18	22	24	3	8	6 1/2	4	6 7/8	6 7/8	1 29/32	7 5/8	6 3/4	6 1/2	18	6 1/2	21 1/8	15 1/8
20	24	24	3	9	7 1/2	4 1/2	7 7/8	7 7/8	1 29/32	8 3/4	7 3/4	7 1/2	20	7 1/2	23 5/8	17 5/8

* NPTF ports are available at no extra charge.

† Optional SAE flange ports may be specified – flange to be supplied by customer. See Table 4 for flange port pattern dimensions.

** SAE straight thread ports are standard and are indicated by port number. Dimension CD is pin diameter.

Table 2—Rod Dimensions

Bore	Rod Dia. MM	Thread KK	Rod Extensions and Pilot Dimensions										Add Stroke					
			A	+0.000 -0.005 B	C	F	LAF	NA	RD	V	WF	XG	Min. XI*	Y	XC	XJ	ZB	ZC
10	4 1/2	3 1/4-12	4 1/2	5.249	1	1 15/16	7 7/16	4 3/8	8 1/4	1 1/4	2 15/16	4 3/4	9 1/16	4 3/4	19 1/16	13 3/8	16 11/32	22 9/16
	7	5-12	7	7.999	1	1 15/16	10 1/2	6 7/8	10 1/2	3/8	3 1/2	5 5/16	9 5/8	5 5/16	19 5/8	13 15/16	16 29/32	23 1/8
	5	3 1/2-12	5	5.749	1	1 15/16	8 3/16	4 7/8	8 7/8	1/4	3 3/16	5	9 5/16	5	19 5/16	13 5/8	16 19/32	22 13/16
12	5 1/2	4-12	5 1/2	6.249	1	1 15/16	8 11/16	5 3/8	9 3/8	1/4	3 3/16	5	9 5/16	5	19 5/16	13 5/8	16 19/32	22 13/16
	8	5 3/4-12	8	8.999	1	1 15/16	12	7 7/8	12 1/2	3/8	4	6 3/16	11 1/2	6 3/16	23	16 5/16	19 29/32	27
	7	5-12	7	7.999	1	1 15/16	10 1/2	6 7/8	10 1/2	3/8	3 1/2	5 1/16	10 15/16	5 1/16	22 1/2	15 13/16	19 13/32	26 1/2
14	7	5-12	7	7.999	1	1 15/16	10 1/2	6 7/8	10 1/2	3/8	3 1/2	5 15/16	11 7/16	5 7/8	24 7/8	16 11/16	20 17/32	29 7/8
	10	7 1/4-12	10	10.999	1	1 15/16	14 1/2	9 7/8	14 1/2	3/8	4 1/2	6 15/16	12 7/16	6 7/8	25 7/8	17 11/16	21 17/32	30 7/8
	8	5 3/4-12	8	8.999	1	1 15/16	12	7 7/8	12 1/2	3/8	4	6 7/16	11 15/16	6 3/8	25 3/8	17 3/8	21 1/32	30 3/8
16	8	5 3/4-12	8	8.999	1	1 15/16	12	7 7/8	12 1/2	3/8	4	**	**	7	29 1/8	**	**	35 1/8
	9	6 1/2-12	9	9.999	1	1 15/16	13 1/4	8 7/8	13 1/2	3/8	4 1/4	**	**	7 1/4	29 3/8	**	**	35 3/8
	10	7 1/4-12	10	10.999	1	1 15/16	14 1/2	9 7/8	14 1/2	3/8	4 1/2	**	**	7 1/2	29 5/8	**	**	35 5/8
18	9	6 1/2-12	9	9.999	1	1 15/16	13 1/4	8 7/8	13 1/2	3/8	4 1/4	**	**	7 1/4	33	**	**	39 1/2
	10	7 1/4-12	10	10.999	1	1 15/16	14 1/2	9 7/8	14 1/2	3/8	4 1/2	**	**	7 1/2	33 1/4	**	**	39 3/4
20	10	7 1/4-12	10	10.999	1	1 15/16	14 1/2	9 7/8	14 1/2	3/8	4 1/2	**	**	7 1/2	36 7/8	**	**	44 3/8

* Dimension XI to be specified by customer. **Consult Factory.

Table 4—Optional SAE Flange Port Pattern

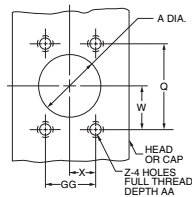

Nom. Flange Size	S.A.E. Flange Dash Size	A	Q	GG	W	X	Z-THD UNC-2B	AA Min.
1 1/2	-24	1.50	2.750	1.406	1.38	0.70	1/2-13	1.06
2	-32	2.00	3.062	1.688	1.53	0.84	1/2-13	1.06
2 1/2	-40	2.50	3.500	2.000	1.75	1.00	1/2-13	1.19
3	-48	3.00	4.188	2.438	2.09	1.22	5/8-11	1.19

Table 5—Tie Rod Information

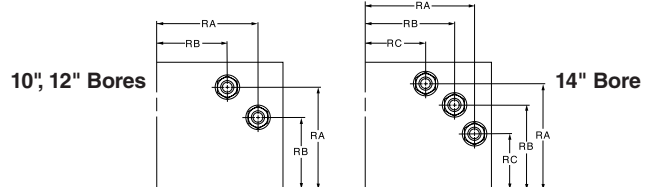

Bore	10	12	14	16	18	20
Tie Rod Thread	1 1/8-12	1 1/4-12	1 1/4-12	*	*	*
RA	5.291	6.270	7.485	*	*	*
RB	3.775	4.555	6.143	*	*	*
RC	—	—	4.409	*	*	*

*Consult factory for dimensions

How to Use Double Rod Cylinder Dimensioned Drawings

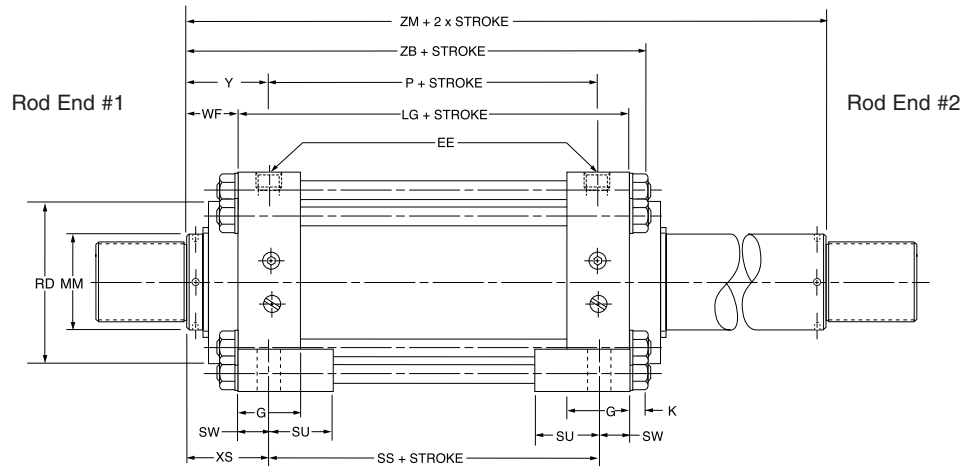
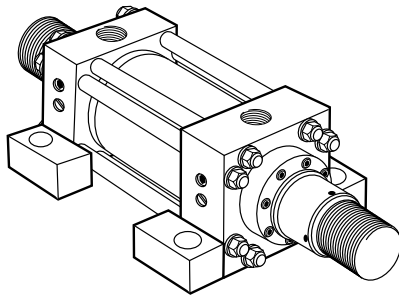

Mounting Styles for Single Rod Models	Dimension Shown on This Page Supplement Dimensions on Pages Listed Below
NM3	36, 37
NM2	36, 37
NM1	36, 37
ME5	38, 39
IH3	38, 39
SL	40, 41
TM1	42, 43
TM3‡	42, 43

* If only one end of these Double Rod Cylinders is to be cushioned, be sure to specify clearly which end this will be.

‡ Specify XI dimension from rod end #1.

To obtain dimensioning information on a double rod cylinder, first select the desired mounting style and refer to the corresponding single rod cylinder model shown on the preceding pages. (See table at left.) After you have determined all necessary dimensions from that drawing, turn back to this page and supplement those dimensions with additional ones from the drawing above and table at right. These added dimensions differ from, or are in addition to, those shown on the preceding pages and provide the additional information needed to completely dimension a double rod cylinder model.

On a double rod cylinder where the two rod ends are different, be sure to clearly state which rod end is to be assembled at which end. Port position 1 is standard. If other than standard, specify pos. 2, 3 or 4 when viewed from rod end #1 only. See port position information on page 60.

Bore	Rod Dia.	Add 2X Stroke
		ZM
10	4 1/2	18
	7	19 1/8
	5	18 1/2
	5 1/2	18 1/2
12	5 1/2	20 7/8
	8	22 1/2
14	7	21 1/2
	7	22 5/8
	10	24 5/8
16	8	23 5/8
	8	26 1/8
	9	26 5/8
18	10	27 1/8
	9	29 5/8
20	10	30 1/8
	10	32 5/8

Mounting Recommendations and Other Mountings

In addition to the standard mountings dimensioned on the preceding pages, the following information covers mounting ideas that may prove helpful in your applications. When needed, special heads, caps, and flanges can be provided. Sketches of your requirements, together with specifications relative to the application and forces involved should be submitted.

Mounting Bolts — High tensile socket head screws are recommended for all mounting styles. Use 1/16" smaller than hole size.

Flange Mountings — Cylinders can be properly centered by measuring from piston rod diameter. After mounting, the flange may be drilled for pins or dowels to prevent shifting.

Side Lug Mountings — Caution, cylinders which do not absorb force on their centerline (Group 3) tend to sway when under load. Short stroke, non-centerline mounted cylinders can subject mounting bolts to large tension forces which when combined with shear forces can overstress standard mounting bolts. Side lug mounted cylinders should always be prevented from shifting through use of shear keys so located as to resist the major load, whether push or pull.

Trunnion Mountings — Cylinders require lubricated pillow blocks with minimum bearing clearances. Pillow blocks should be carefully aligned and rigidly mounted so the trunnions will not be subjected to bending moments. The rod end connection should also be pivoted, with the customer's pin in the piston rod eye parallel to the trunnions.

Clevis Mountings — Cylinders should be pivoted at both ends, with the customer's pin in the piston rod eye parallel to the pivot pin supplied with the clevis.

Metallic Rod Wiper

When specified, metallic rod wipers can be supplied at extra cost, instead of the standard synthetic rubber wiperseal. Recommended in applications where atmospheric particles or splashing tend to cling to the extended piston rod and otherwise damage the synthetic rubber wiperseal. Installation of metallic rod wiper does not affect cylinder dimensions.

Linear Alignment Couplers are available in 19 standard thread sizes...

Cost Saving Features and Benefits Include...

- Maximum reliability for trouble-free operation, long life and lower operating costs
- Simplifying cylinder installation and reducing assembly costs
- Increased cylinder life by reducing wear on piston and rod bearings
- Increase rod bearing and rod seal life for lower maintenance costs

Alignment Coupler

See Table 1 for Part Numbers and Dimensions

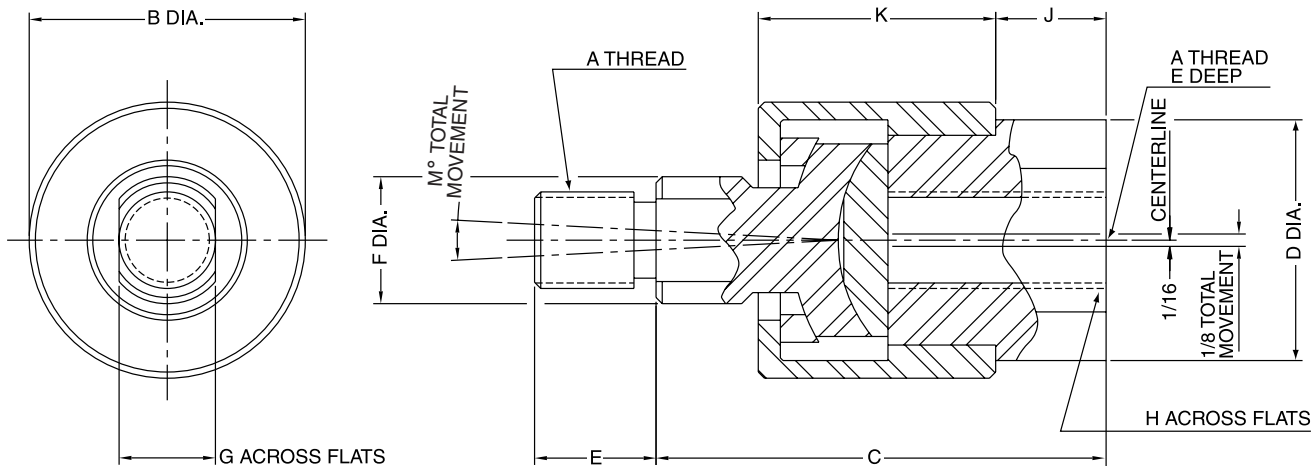

Table 1 — Part Numbers and Dimensions

Part No.	A	B	C	D	E	F	G	H	J	K	M	Max. Pull Load (lbs.)	Approx. Weight (lbs.)
RC-3-5	5/16-24	1 1/8	1 3/4	15/16	1/2	1/2	3/8	3/4	3/8	15/16	6°	1200	.35
RC-3-6	3/8-24	1 1/8	1 3/4	15/16	1/2	1/2	3/8	3/4	3/8	15/16	6°	2425	.35
RC-3-7	7/16-20	1 3/8	2	1 1/8	3/4	5/8	1/2	7/8	3/8	1 3/32	6°	3250	.55
RC-3-8	1/2-20	1 3/8	2	1 1/8	3/4	5/8	1/2	7/8	3/8	1 3/32	6°	4450	.55
RC-3-10	5/8-18	1 3/8	2	1 1/8	3/4	5/8	1/2	7/8	3/8	1 3/32	6°	6800	.55
RC-3-12	3/4-16	2	2 5/16	1 5/8	1 1/8	15/16	3/4	1 5/16	7/16	1 9/32	6°	9050	1.4
RC-3-14	7/8-14	2	2 5/16	1 5/8	1 1/8	15/16	3/4	1 5/16	7/16	1 9/32	6°	14450	1.4
RC-3-16	1-14	3 1/8	3	2 3/8	1 5/8	1 7/16	1 1/4	1 7/8	3/4	1 25/32	6°	19425	4.8
RC-3-20	1 1/4-12	3 1/8	3	2 3/8	1 5/8	1 7/16	1 1/4	1 7/8	3/4	1 25/32	6°	30500	4.8
RC-2-24	1 1/2-12	4	4 3/8	2 1/4	2 1/4	1 3/4	1 1/2	1 15/16	7/8	2 3/4	10°	45750	9.8
RC-2-28	1 3/4-12	4	4 3/8	2 1/4	2 1/4	1 3/4	1 1/2	1 15/16	7/8	2 3/4	10°	58350	9.8
RC-2-30	1 7/8-12	5	5 5/8	3	3	2 1/4	1 15/16	2 5/8	1 3/8	3 3/8	10°	67550	19.8
RC-2-32	2-12	5	5 5/8	3	3	2 1/4	1 15/16	2 5/8	1 3/8	3 3/8	10°	77450	19.8
RC-2-36	2 1/4-12	6 3/4	6 3/8	3 1/4	3 1/2	2 3/4	2 3/8	2 7/8	1 5/8	3 3/4	10°	99250	35.3
RC-2-40	2 1/2-12	7	6 1/2	4	3 1/2	3 1/4	2 7/8	3 3/8	1 5/8	3 7/8	10°	123750	45.3
RC-2-44	2 3/4-12	7	6 1/2	4	3 1/2	3 1/4	2 7/8	3 3/8	1 5/8	3 7/8	10°	150950	45.3
RC-2-48	3-12	7	6 1/2	4	3 1/2	3 1/4	2 7/8	3 3/8	1 5/8	3 7/8	10°	180850	45.3
RC-2-52	3 1/4-12	9 1/4	8 1/2	5 1/4	4 1/2	4	3 3/8	4 1/2	2	5 1/2	10°	213450	—
RC-2-68	4 1/4-12	12 7/8	11 1/4	7 3/4	4 1/2	5 1/2	4 7/8	7	1 1/2	8 3/4	10°	370850	—

How to Order Linear Alignment Couplers — When ordering a cylinder with a threaded male rod end, specify the coupler of equal thread size by part number as listed in Table 1, i.e.; Piston Rod “KK” dimension is 3/4" - 16", specify coupler part number RC-3-12.

Cylinder Accessories

Atlas offers a complete range of cylinder accessories to assure you of the greatest versatility in present and future cylinder applications.

Rod End Accessories

Accessories offered for the rod end of the cylinder include Rod Clevis, Eye Bracket, Female Rod Eye, Clevis Bracket, and Pivot Pin. To select the proper part number for any desired accessory, refer to the table below or on the [opposite page](#) and look in the row to the right of the rod thread in the first column. For economical accessory selection, it is recommended that rod end style 1 be specified on your cylinder order.

Accessory Load Capacity

The various accessories have been load rated for your convenience. The load Capacity in lbs. Is the recommended maximum load for that accessory based on a 4:1 design factor in tension. (Pivot Pin is rated in shear.) Before specifying, compare the actual load or the tension (pull) force at maximum operating pressure of the cylinder with the load capacity of the accessory you plan to use. If load or pull force of cylinder exceeds load capacity of accessory, consult factory.

Thread Size	Rod Clevis		Eye Bracket		Pivot Pin	
	Part Number	Load Capacity (Lbs.)	Part Number	Load Capacity (Lbs.)	Part Number	Shear Capacity (Lbs.)
7/16-20	JIC-40	2950	EB-195	3375	PP-368A	58900
1/2-20	JIC-41	4000	EB-195	3375	PP-368A	58900
3/4-16	JIC-42A	11200	EB-196	8400	PP-369A	13250
3/4-16	JIC-42	9300	EB-196	8400	PP-369A	13250
7/8-14	JIC-43A	18800	EB-197	13500	PP-370A	23560
7/8-14	JIC-43	12700	EB-197	13500	PP-370A	23560
1-14	JIC-44A	19500	EB-197	13500	PP-370A	23560
1-14	JIC-44	16875	EB-197	13500	PP-370A	23560
1 1/4-12	JIC-45A	33500	EB-198	24700	PP-371A	44550
1 1/4-12	JIC-45	26800	EB-198	24700	PP-371A	44550
1 1/2-12	JIC-46	39500	EB-199	39375	PP-372A	72150
1 3/4-12	JIC-47	54700	EB-200	45000	PP-215A	94250
1 7/8-12	JIC-48	56250	EB-200	45000	PP-215A	94250
2 1/4-12	JIC-49	84375	EB-201	67500	PP-374A	94250
2 1/2-12	JIC-50	84375	EB-202	67500	PP-375A	147250
2 3/4-12	JIC-51	84375	EB-202	67500	PP-216A	212050
3 1/4-12	JIC-52A	156700	EB-38	126000	PP-545A	288600
3 1/4-12	JIC-52	157500	EB-38	126000	PP-545A	288600
3 1/2-12	JIC-53A	193200	EB-39	162000	PP-547A	377000
3 1/2-12	JIC-53	202500	EB-39	162000	PP-547A	377000
4-12	JIC-54A	221200	EB-39	162000	PP-547A	377000
4-12	JIC-54	202500	EB-39	162000	PP-547A	377000

Rod Clevis Dimensions

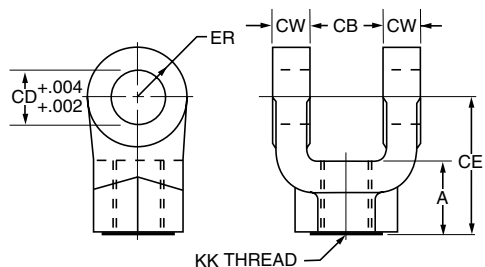

Pivot Pin Dimensions

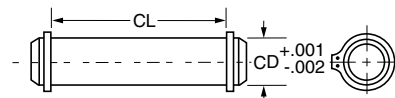

Part Number	A	CB	CD	CE	CW	ER	KK
JIC-40	3/4	3/4	1/2	1 1/2	1/2	1/2	7/16-20
JIC-41	3/4	3/4	1/2	1 1/2	1/2	1/2	1/2-20
JIC-42A	1 1/8	1 1/4	3/4	2 1/8	5/8	3/4	3/4-16
JIC-42	1 1/8	1 1/4	3/4	2 3/8	5/8	3/4	3/4-16
JIC-43A	1 5/8	1 1/2	1	2 15/16	3/4	1	7/8-14
JIC-43	1 5/8	1 1/2	1	3 1/8	3/4	1	7/8-14
JIC-44A	1 5/8	1 1/2	1	2 15/16	3/4	1	1-14
JIC-44	1 5/8	1 1/2	1	3 1/8	3/4	1	1-14
JIC-45A	1 7/8	2	1 3/8	3 3/4	1	1 3/8	1 1/4-12
JIC-45	2	2	1 3/8	4 1/8	1	1 3/8	1 1/4-12
JIC-46	2 1/4	2 1/2	1 3/4	4 1/2	1 1/4	1 3/4	1 1/2-12
JIC-47	3	2 1/2	2	5 1/2	1 1/4	2	1 3/4-12
JIC-48	3	2 1/2	2	5 1/2	1 1/4	2	1 7/8-12
JIC-49	3 1/2	3	2 1/2	6 1/2	1 1/2	2 1/2	2 1/4-12
JIC-50	3 1/2	3	3	6 3/4	1 1/2	2 3/4	2 1/2-12
JIC-51	3 1/2	3	3	6 3/4	1 1/2	2 3/4	2 3/4-12
JIC-52A	3 1/2	4	3 1/2	7 3/4	2	3 1/2	3 1/4-12
JIC-52	4 1/2	4	3 1/2	8 1/2	2	3 1/2	3 1/4-12
JIC-53A	4 ‡	4 1/2	4	8 13/16	2 1/4	4	3 1/2-12
JIC-53	5	4 1/2	4	9 13/16	2 1/4	4	3 1/2-12
JIC-54A	4 ‡	4 1/2	4	8 13/16	2 1/4	4	4-12
JIC-54	5 1/2	4 1/2	4	10	2 1/4	4	4-12

Part Number	CD	CL
PP-368A	1/2	1 7/8
PP-369A	3/4	2 5/8
PP-370A	1	3 1/8
PP-371A	1 3/8	4 1/8
PP-372A	1 3/4	5 3/16
PP-373A	2	5 3/16
PP-374A	2 1/2	6 3/16
PP-375A	3	6 1/4
PP-545A	3 1/2	8 1/4
PP-547A	4	9

1. Pivot Pins are furnished with Clevis Mounted Cylinders as standard.
2. Pivot Pins are furnished with (2) Retainer Rings.

‡Consult appropriate cylinder rod end dimensions for compatibility.
 Part numbers for Rod Clevis include pins and keepers.

Eye Bracket Dimensions

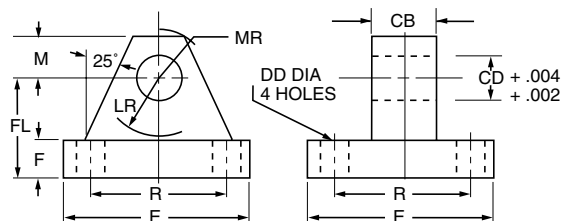

1. When used to mate with the Rod Clevis, select by thread size in table above.
2. When used to mount the Style PB2 Cylinder, select by bore size below.

Part Number	CB	CD	DD	E	F	FL	LR	M	MR	R	Bore
EB-195	3/4	1/2	13/32	2 1/2	3/8	1 1/8	3/4	1/2	9/16	1.63	1 1/2"
EB-196	1 1/4	3/4	17/32	3 1/2	5/8	1 7/8	1 1/4	3/4	7/8	2.55	2", 2 1/2"
EB-197	1 1/2	1	21/32	4 1/2	3/4	2 1/4	1 1/2	1	1 1/4	3.25	3 1/4"
EB-198	2	1 3/8	21/32	5	7/8	3	2 1/8	1 3/8	1 5/8	3.82	4"
EB-199	2 1/2	1 3/4	29/32	6 1/2	7/8	3 1/8	2 1/4	1 3/4	2 1/8	4.95	5"
EB-200	2 1/2	2	1 1/16	7 1/2	1	3 1/2	2 1/2	2	2 7/16	5.73	6"
EB-201	3	2 1/2	1 3/16	8 1/2	1	4	3	2 1/2	3	6.58	7"
EB-202	3	3	1 5/16	9 1/2	1	4 1/4	3 1/4	2 3/4	3 1/4	7.50	8"
EB-38	4	3 1/2	1 13/16	12 5/8	1 11/16	5 11/16	4	3 1/2	4 1/8	9.62	10"
EB-39	4 1/2	4	2 1/16	14 7/8	1 15/16	6 7/16	4 1/2	4	5 1/4	11.45	12"

Rod End Accessories

Accessories offered for the rod end of the cylinder include Rod Clevis, Eye Bracket, Female Rod Eye, Clevis Bracket, and Pivot Pin. To select the proper part number for any desired accessory, refer to the table below or on the [opposite page](#) and look in the row to the right of the rod thread in the first column. For economical accessory selection, it is recommended that rod end style 1 be specified on your cylinder order.

Accessory Load Capacity

The various accessories have been load rated for your convenience. The load Capacity in lbs. is the recommended maximum load for that accessory based on a 4:1 design factor in tension. (Pivot Pin is rated in shear.) Before specifying, compare the actual load or the tension (pull) force at the maximum operating pressure of the cylinder with the load capacity of the accessory you plan to use. If load or pull force of cylinder exceeds load capacity of accessory, consult factory.

Thread Size	Female Rod Eye		Clevis Bracket		Pivot Pin	
	Part Number	Load Capacity (Lbs.)	Part Number	Load Capacity (Lbs.)	Part Number	Shear Capacity (Lbs.)
7/16-20	REE-89	2950	CB-205	4500	PP-368A	5890
1/2-20	REE-90	3375	CB-205	4500	PP-368A	5890
3/4-16	REE-91	8400	CB-206	8400	PP-369A	13250
7/8-14	REE-92	12700	CB-207	13500	PP-370A	23560
1-14	REE-93	13500	CB-207	13500	PP-370A	23560
1 1/4-12	REE-94	24750	CB-208	24700	PP-371A	44550
1 1/2-12	REE-95	39375	CB-209	39375	PP-372A	72150
1 3/4-12	REE-96	45000	CB-210	54000	PP-215A	94250
1 7/8-12	REE-97	45000	CB-210	54000	PP-215A	94250
2 1/4-12	REE-98	67500	CB-211	67500	PP-374A	147250
2 1/2-12	REE-99	81000	CB-212	124000	PP-375A	212050
2 3/4-12	REE-100	94500	CB-213	124000	PP-216A	212050
3 1/4-12	REE-36	126000	CB-242	126000	PP-545A	288600
3 1/2-12	REE-37	126000	CB-242	126000	PP-545A	288600
4-12	REE-38	162000	CB-243	144000	PP-546A	288600
4 1/2-12	REE-39	180000	CB-244	144000	PP-547A*	377000

*This size supplied with cotter pins.

Female Rod Eye Dimensions

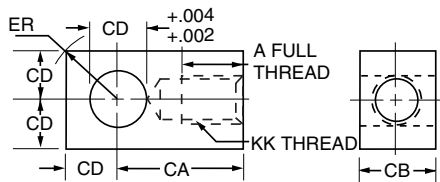

Pivot Pin Dimensions

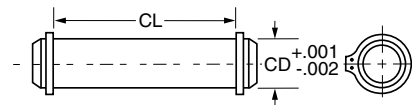

Part Number	A	CA	CB	CD	ER	KK
REE-89	3/4	1 1/2	3/4	1/2	23/32	7/16-20
REE-90	3/4	1 1/2	3/4	1/2	23/32	1/2-20
REE-91	1 1/8	2 1/16	1 1/4	3/4	1 1/16	3/4-16
REE-92	1 1/8	2 3/8	1 1/2	1	1 7/16	7/8-14
REE-93	1 5/8	2 13/16	1 1/2	1	1 7/16	1-14
REE-94	2	3 7/16	2	1 3/8	1 31/32	1 1/4-12
REE-95	2 1/4	4	2 1/2	1 3/4	2 1/2	1 1/2-12
REE-96	2 1/4	4 3/8	2 1/2	2	2 27/32	1 3/4-12
REE-97	3	5	2 1/2	2	2 27/32	1 7/8-12
REE-98	3 1/2	5 13/16	3	2 1/2	3 9/16	2 1/4-12
REE-99	3 1/2	6 1/8	3	3	4 1/4	2 1/2-12
REE-100	3 5/8	6 1/2	3 1/2	3	4 1/4	2 3/4-12
REE-36	4 1/2	7 5/8	4	3 1/2	4 31/32	3 1/4-12
REE-37	5	7 5/8	4	3 1/2	4 31/32	3 1/2-12
REE-38	5 1/2	9 1/8	4 1/2	4	5 11/16	4-12
REE-39	5 1/2	9 1/8	5	4	5 11/16	4 1/2-12

Part Number	CD	CL
PP-368A	1/2	1 7/8
PP-369A	3/4	2 5/8
PP-370A	1	3 1/8
PP-371A	1 3/8	4 1/8
PP-372A	1 3/4	5 3/16
PP-215A	2	5 11/16
PP-374A	2 1/2	6 3/16
PP-375A	3	6 1/4
PP-216A	3	6 3/4
PP-545A	3 1/2	8 1/4
PP-546A	4	8 5/8
PP-547A*	4	9

1. Pivot Pins are furnished with Clevis Mounted Cylinders as standard.
2. Pivot Pins are furnished with (2) Retainer Rings.

Clevis Bracket Dimensions

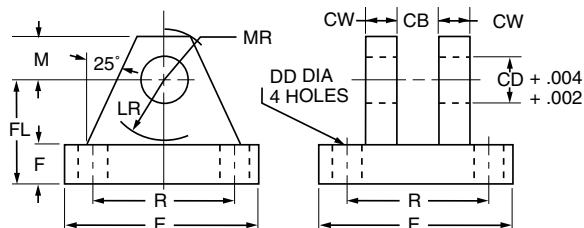

Part Number	CB	CD	CW	DD	E	F	FL	LR	M	MR	R
CB-205	3/4	1/2	1/2	13/32	3 1/2	1/2	1 1/2	3/4	1/2	5/8	2.55
CB-206	1 1/4	3/4	5/8	17/32	5	5/8	1 7/8	1 3/16	3/4	29/32	3.82
CB-207	1 1/2	1	3/4	21/32	6 1/2	3/4	2 1/4	1 1/2	1	1 1/4	4.95
CB-208	2	1 3/8	1	21/32	7 1/2	7/8	3	2	1 3/8	1 21/32	5.73
CB-209	2 1/2	1 3/4	1 1/4	29/32	9 1/2	7/8	3 5/8	2 3/4	1 3/4	2 7/32	7.50
CB-210	2 1/2	2	1 1/2	1 1/16	12 3/4	1	4 1/4	3 3/16	2 1/4	2 25/32	9.40
CB-211	3	2 1/2	1 1/2	1 3/16	12 3/4	1	4 1/2	3 1/2	2 1/2	3 1/8	9.40
CB-212	3	3	1 1/2	1 5/16	12 3/4	1	6	4 1/4	3	3 19/32	9.40
CB-213	3 1/2	3	1 1/2	1 5/16	12 3/4	1	6	4 1/4	3	3 19/32	9.40
CB-242	4	3 1/2	2	1 13/16	15 1/2	1 11/16	6 11/16	5	3 1/2	4 1/8	12.00
CB-243	4 1/2	4	2	2 1/16	17 1/2	1 15/16	7 11/16	5 3/4	4	4 7/8	13.75
CB-244	5	4	2	2 1/16	17 1/2	1 15/16	7 11/16	5 3/4	4	4 7/8	13.75

- This size supplied with cotter pins.
- Part numbers for clevis bracket include pins and keepers.

Spherical Bearings for Series H Cylinders

Spherical Bearing Mount That Maintains Alignment Through Push and Pull Strokes.

Benefits Are...

- Simplify installation of cylinder
- Reduce cylinder friction
- Eliminate side loading in hard to align applications
- Increase cylinder life by reducing wear on piston and rod bearings
- Save assembly time
- Maintain alignment through push and pull strokes
- Increase rod bearing and rod seal life
- Simplify machine design problems



Series H hydraulic cylinders are available with spherical bearing mounts at both ends or head and cap end only. The bearing at the cap end is housed in a single stud ear welded to the cap to form an integral structure. At the head end the bearing is mounted in a steel rod eye threaded to the piston rod. Grease fittings are provided for lubrication.

The spherical bearing mount provides swivel connections at both ends of the cylinder to reduce misalignment problems and to maintain alignment through push and pull strokes.

The bearing races are designed primarily for radial loads and moderate misalignment not to exceed angle "a" as shown in Table 1 on the [next page](#).

The accessories, rod eye, pivot pin and clevis brackets are all designed to take maximum loading of the cylinder.

Application and Design Data

The spherical bearing life is influenced by many factors, i.e., bearing pressure, load direction oscillating angle and lubrication. The maximum operating pressure ratings of the spherical bearing mountings are based on standard commercial bearing ratings. The 4:1 design factor rating is based on the tensile strength of the material.

The spherical bearings are dimensioned to ensure a satisfactory bearing life under normal operating conditions. The bearing races are made of through-hardened steel and are precision ground. They are phosphate treated and coated with dry film lubricant to minimize friction of contacting surfaces. In the case of a permanent unidirectional load to the bearing, or other unusual operating conditions, the use of a larger bearing may be required.

For longer bearing life, regular lubrication will protect the spherical plain bearing from premature wear and corrosion. Rust-inhibiting EP greases of lithium/lead base, preferably with molybdenum disulphide additives are particularly suited. The radial bearings have lubricating holes and grooves in the races permitting lubrication. The bearing housings at the cap and rod end are provided with grease fittings for lubrication.

Maximum angle of swivel in relation to the center line of the pivot pin is shown as angle **a** in the table below. It is recommended that this angle is not exceeded when mounting the cylinder.

Mounting Information

Head End Mounting

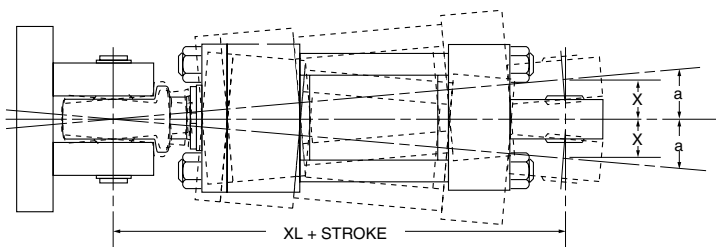

Recommended maximum swivel angle on each side of the cylinder centerline.

Table 1

Bore	Head End Mounted		Cap End Mounted	
	Angle a	Tan. of a	Angle a	Tan. of a
1½	2°	.035	2°	.035
2	2½°	.044	4½°	.079
2½	2½°	.044	4½°	.079
3¼	3°	.052	3°	.052
4	2½°	.044	3°	.052
5	3°	.052	3°	.052
6	3°	.052	3°	.052

Note: Dimension X is the maximum off center mounting of the cylinder. To determine dimension X for various stroke lengths multiply distance between pivot pin holes by tangent of angle **a**. For extended position use $X = XL + 2X$ stroke.

Cap End Mounting

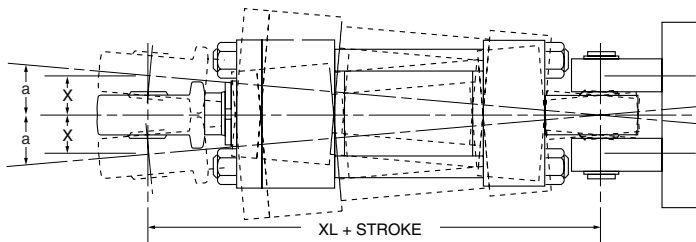

Cap Fixed Eye Mount
with Spherical Bearing
Style SA

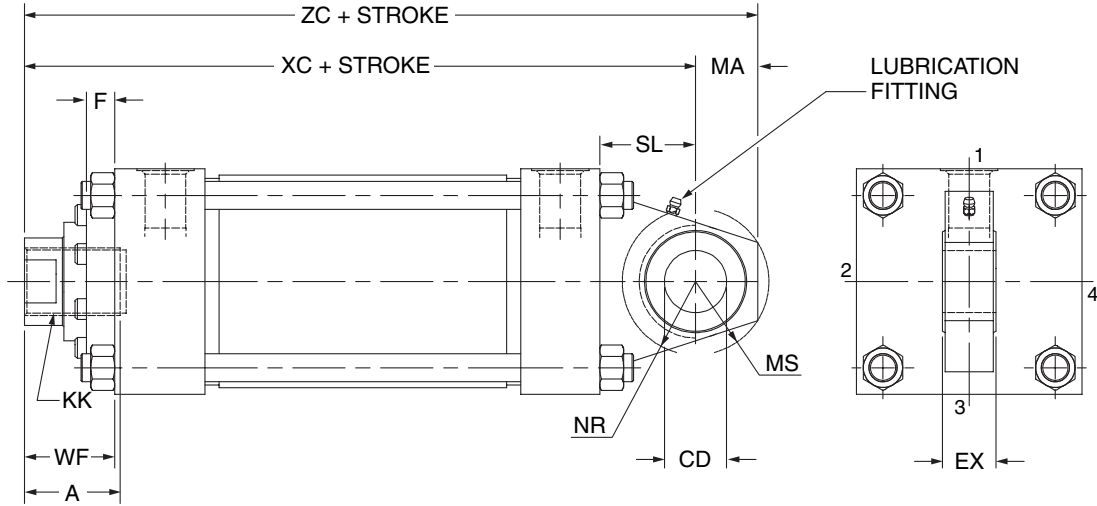

Table 1 — Dimensions

Bore	Rod Dia. MM	Thread Style 3 KK	A	WF	Add Stroke		CD*	EX	MA	MS	NR	SL	Max. Oper. PSI†
					XC	ZC							
1½	5/8	7/16-20	3/4	1	6¾	7½	.5000 ^{-0.0005}	7/16	¾	15/16	5/8	¾	1500
	1	¾-16	1½	1¾	6¾	7½							
2	1	¾-16	1½	1¾	7¼	8¼	.7500 ^{-0.0005}	21/32	1	1¾	1	1¼	2200
	1¾	1-14	1½	1½	7½	8½							
2½	1	¾-16	1½	1¾	7¾	8¾	.7500 ^{-0.0005}	21/32	1	1¾	1	1¼	1450
	1¾	1-14	1½	1½	7¾	8¾							
	1¾	1-14	1½	1½	7¾	8¾							
3¼	1¾	1-14	1½	1½	8½	9¾	1.0000 ^{-0.0005}	7/8	1¼	1 11/16	1¼	1½	1500
	2	1½-12	2¼	2	9	10¼							
	1¾	1¼-12	2	17/8	8¾	10½							
4	1¾	1¼-12	2	17/8	9¾	11½	1.3750 ^{-0.0005}	13/16	17/8	27/16	15/8	2½	1850
	2½	17/8-12	3	2¼	10½	12							
	2	1½-12	2¼	2	9¾	11¾							
5	2	1½-12	2¼	2	10½	13	1.7500 ^{-0.0005}	1 17/32	2½	27/8	2 1/16	2¼	2000
	3½	2½-12	3½	2¼	10¾	13¼							
	2½	17/8-12	3	2¼	10¾	13¼							
	3	2¼-12	3½	2¼	10¾	13¼							
6	2½	17/8-12	3	2¼	12½	14½	2.0000 ^{-0.0005}	1¾	2½	3 5/16	2¾	2½	1800
	4	3-12	4	2¼	12½	14½							
	3	2¼-12	3½	2¼	12½	14½							
	3½	2½-12	3½	2¼	12½	14½							

† Maximum operating pressure at 4:1 design factor is based on tensile strength of material. Pressure ratings are based on standard commercial bearing ratings.

* Dimension "CD" is hole diameter.

**To match pin diameter in rod eye and cap, when an oversize rod is required, specify rod end style '4', 'KK' thread and 'A' thread length for the standard rod diameter (first rod listed for the bore), and 'W' for the oversize rod. Order the rod eye and clevis bracket for the required bore size from the tables on the [spherical bearings accessory page](#).

Atlas offers a complete range of Cylinder Accessories to assure you of the greatest versatility in present or future cylinder applications. Accessories offered for the

respective cylinder include the Rod Eye, Pivot Pin and Clevis Bracket. To select the proper part number for any desired accessory refer to the charts below.

Spherical Rod Eye

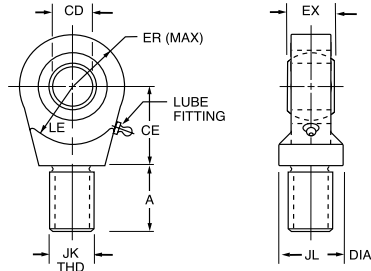

Order to fit Piston Rod Thread Size.

Bore Sizes	1 1/2	2 & 2 1/2	3 1/4	4	5	6
Part No.	SB-1	SB-2	SB-3	SB-4	SB-5	SB-6
CD	.5000-.0005	.7500-.0005	1.0000-.0005	1.3750-.0005	1.7500-.0005	2.0000-.0005
A	1 1/16	1	1 1/2	2	2 1/8	2 7/8
CE	7/8	1 1/4	1 7/8	2 1/8	2 1/2	2 3/4
EX	7/16	2 1/32	7/8	1 3/16	1 17/32	1 3/4
ER	7/8	1 1/4	1 3/8	1 13/16	2 3/16	2 5/8
LE	3/4	1 1/16	1 7/16	1 7/8	2 1/8	2 1/2
JK	7/16-20	3/4-16	1-14	1 1/4-12	1 1/2-12	1 7/8-12
JL	7/8	1 5/16	1 1/2	2	2 1/4	2 3/4
LOAD CAPACITY LBS.	2644	9441	16860	28562	43005	70193

Pivot Pin

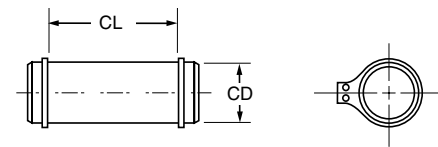

Pivot Pins are furnished with (2) Retainer Rings.

Bore Sizes	1 1/2	2 & 2 1/2	3 1/4	4	5	6
Part No.	PP-616	PP-624	PP-632	PP-644	PP-656	PP-654
CD	.4997-.0004	.7497-.0005	.9997-.0005	1.3746-.0006	1.7496-.0006	1.9996-.0007
CL	1 9/16	2 1/32	2 1/2	3 5/16	4 7/32	4 15/16
SHEAR CAPACITY LBS.	8600	19300	34300	65000	105200	137400

Clevis Bracket

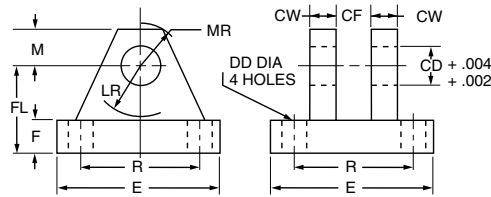

Order to fit Cap or Rod Eye.

Bore Sizes	1 1/2	2 & 2 1/2	3 1/4	4	5	6
Part No.	SAB-1	SAB-2	SAB-3	SAB-4	SAB-5	SAB-6
CD	1/2	3/4	1	1 3/8	1 3/4	2
CF	7/16	2 1/32	7/8	1 3/16	1 17/32	1 3/4
CW	1/2	5/8	3/4	1	1 1/4	1 1/2
DD	1 3/32	1 7/32	1 7/32	2 1/32	2 9/32	2 9/32
E	3	3 3/4	5 1/2	6 1/2	8 1/2	10 5/8
F	1/2	5/8	3/4	7/8	1 1/4	1 1/2
FL	1 1/2	2	2 1/2	3 1/2	4 1/2	5
LR	1 5/16	1 3/8	1 11/16	2 7/16	2 7/8	3 5/16
M	1/2	7/8	1	1 3/8	1 3/4	2
MR	5/8	1	1 3/16	1 5/8	2 1/16	2 3/8
R	2.05	2.76	4.10	4.95	6.58	7.92
LOAD CAPACITY LBS.	5770	9450	14300	20322	37800	50375

Part numbers for clevis bracket include pins and keepers.

Atlas "Style 5" Piston Rod End

Split Flange Coupling Rod End

- Simplifies alignment
- Reduces assembly time
- Allows full rated hydraulic pressure in push and pull directions
- Available in 5/8" through 10" piston rod diameters

Style 5 Rod End

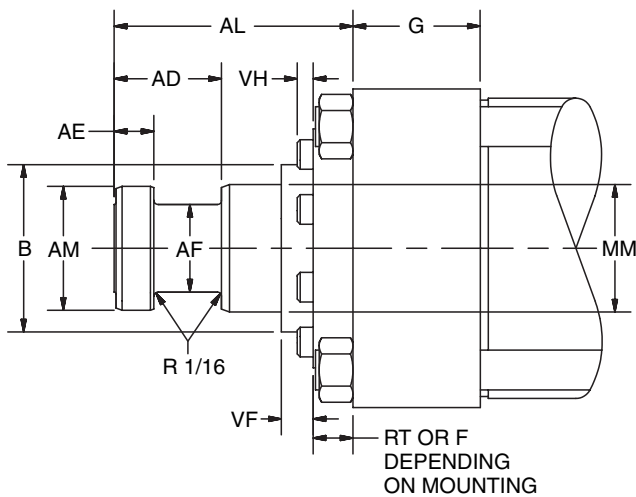

Dimensions Style 5 Rod End

MM Rod Dia.	AD	AE	AF	AM	AL
5/8	5/8	1/4	3/8	.57	1 3/4
1	15/16	3/8	11/16	.95	2 1/2
1 3/8	1 1/16	3/8	7/8	1.32	2 3/4
1 3/4	1 5/16	1/2	1 1/8	1.70	3 1/8
2	1 11/16	5/8	1 3/8	1.95	3 3/4
2 1/2	1 15/16	3/4	1 3/4	2.45	4 1/2
3	2 7/16	7/8	2 1/4	2.95	4 7/8
3 1/2	2 11/16	1	2 1/2	3.45	5 5/8
4	2 11/16	1	3	3.95	5 3/4
4 1/2	3 3/16	1 1/2	3 1/2	4.45	6 1/2
5	3 3/16	1 1/2	3 7/8	4.95	6 5/8 *
5 1/2	3 15/16	1 7/8	4 3/8	5.45	7 1/2 **
7	4 1/16	2	5 3/4	6.95	8 11/16
8	4 1/16	2	6 1/2	7.95	8 15/16
9	4 5/8	2 3/8	7 1/4	8.95	9 3/16
10	4 5/8	2 3/8	8	9.95	9 3/16

* AL = 7 5/16 for 5" diameter rod in 10" bore.

** AL = 8 7/16 for 5 1/2" diameter rod in 10" and 12" bores.

See previous catalog pages for B, F, G, RT, VF and VH per bore and rod diameter.

“Style 5” Piston Rod End

Split Couplers and Weld Plates

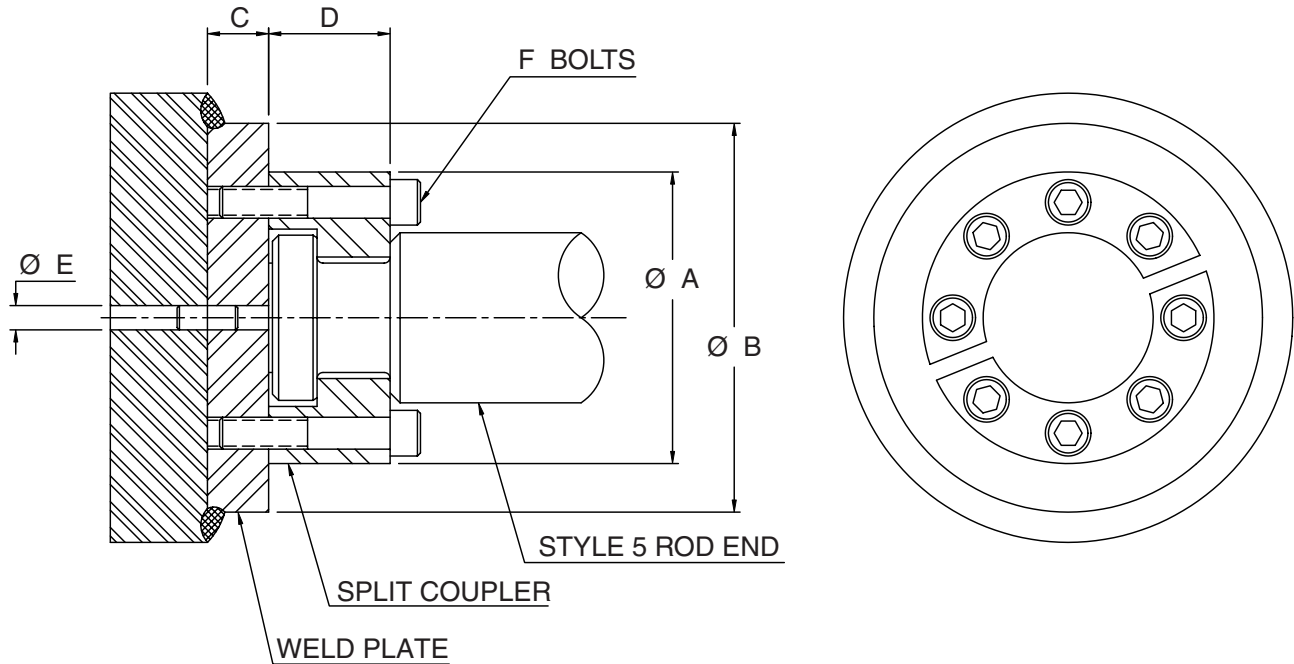

⚠ WARNING: Piston rod separation from the machine member can result in severe personal injury or even death to nearby personnel. The cylinder user must make sure the weld holding the weld plate to the machine is of sufficient quality and size to hold the intended load. The cylinder user must also make sure the bolts holding split coupler to the weld plate are of sufficient strength to hold the intended load and installed in such a way that they will not become loose during the machine’s operation.

Table 1 — Part Numbers and Dimensions

ROD DIA.	A	B	C	D	E	F	BOLT SIZE	SPLIT COUPLER PART NO.	WELD PLATE PART NO.
5/8	1.50	2.00	.50	.56	.250	4	#10-24 x .94 LG	SC-062	WP-062
1	2.00	2.50	.50	.88	.250	6	.250-20 x 1.25 LG	SC-100	WP-100
1 3/8	2.50	3.00	.63	1.00	.250	6	.312-18 x 1.0" LG	SC-138	WP-138
1 3/4	3.00	4.00	.63	1.25	.250	8	.312-18 x 1.75 LG	SC-175	WP-175
2	3.50	4.00	.75	1.63	.375	12	.375-16 x 2.25 LG	SC-200	WP-200
2 1/2	4.00	4.50	.75	1.88	.375	12	.375-16 x 2.50 LG	SC-250	WP-250
3	5.00	5.50	1.00	2.38	.375	12	.500-13 x 3.25 LG	SC-300	WP-300
3 1/2	5.88	7.00	1.00	2.63	.375	12	.625-11 x 3.50 LG	SC-350	WP-350
4	6.38	7.00	1.00	2.63	.375	12	.625-11 x 3.50 LG	SC-400	WP-400
4 1/2	6.88	8.00	1.00	3.13	.375	12	.625-11 x 4.00 LG	SC-450	WP-450
5	7.38	8.00	1.00	3.13	.375	12	.625-11 x 4.00 LG	SC-500	WP-500
5 1/2	8.25	9.00	1.25	3.88	.375	12	.750-10 x 5.00 LG	SC-550	WP-550
7	10.38	11.00	1.75	4.00	.500	12	1.00-8 x 5.50 LG	SC-700	WP-700
8	11.38	12.00	2.00	4.00	.500	16	1.00-8 x 5.50 LG	SC-800	WP-800
9	13.12	14.00	2.25	4.00	.500	12	1.25-7 x 6.00 LG	SC-900	WP-900
10	14.12	15.00	2.50	4.50	.500	16	1.25-7 x 6.50 LG	SC-1000	WP-1000

Note: Screws are not included with split coupler or weld plate.

Push and Pull Forces

Push Force and Displacement

Cyl. Bore Size (Inches)	Piston Area (Sq. In.)	Cylinder Push Stroke Force In Pounds At Various Pressures										Displacement Per Inch Of Stroke (Gallons)
		25	50	65	80	100	250	500	1000	2000	3000	
1½	1.767	44	88	115	142	177	443	885	1770	3540	5310	.00765
2	3.14	79	157	204	251	314	785	1570	3140	6280	9420	.0136
2½	4.91	123	245	319	393	491	1228	2455	4910	9820	14730	.0213
3¼	8.30	208	415	540	664	830	2075	4150	8300	16600	24900	.0359
4	12.57	314	628	817	1006	1257	3143	6285	12570	25140	37710	.0544
5	19.64	491	982	1277	1571	1964	4910	9820	19640	39280	58920	.0850
6	28.27	707	1414	1838	2262	2827	7068	14135	28270	56540	84810	.1224
7	38.49	962	1924	2502	3079	3849	9623	19245	38490	76980	115470	.1666
8	50.27	1257	2513	3268	4022	5027	12568	25135	50270	100540	150810	.2176
10	78.54	1964	3927	5105	6283	7854	19635	39270	78540	157080	235620	.3400
12	113.10	2828	5655	7352	9048	11310	28275	56550	113100	226200	339300	.4896
14	153.94	3849	7697	10006	12315	15394	38485	76970	153940	307880	461820	.6664
16	201.06	5027	10053	13069	16085	20106	50265	100530	201060	402120	603180	.8704
18	254.47	6362	12724	16541	20358	25447	63618	127235	254470	508940	763410	1.1016
20	314.16	7854	15708	20420	25133	31416	78540	157080	314160	628320	942480	1.3600

Deductions for Pull Force and Displacement

Piston Rod Dia. (Inches)	Piston Area (Sq. In.)	Piston Rod Diameter Force In Pounds At Various Pressures										Displacement Per Inch Of Stroke (Gallons)
		To determine Cylinder Pull Force or Displacement, deduct the following Force or Displacement corresponding to Rod Size, from selected Push Stroke Force or Displacement corresponding to Bore Size in table above.										
		25	50	65	80	100	250	500	1000	2000	3000	
5/8	.307	8	15	20	25	31	77	154	307	614	921	.0013
1	.785	20	39	51	65	79	196	392	785	1570	2355	.0034
1 3/8	1.49	37	75	97	119	149	373	745	1490	2980	4470	.0065
1 3/4	2.41	60	121	157	193	241	603	1205	2410	4820	7230	.0104
2	3.14	79	157	204	251	314	785	1570	3140	6280	9420	.0136
2 1/2	4.91	123	245	319	393	491	1228	2455	4910	9820	14730	.0213
3	7.07	177	354	460	566	707	1767	3535	7070	14140	21210	.0306
3 1/2	9.62	241	481	625	770	962	2405	4810	9620	19240	28860	.0416
4	12.57	314	628	817	1006	1257	3143	6285	12570	25140	37710	.0544
4 1/2	15.90	398	795	1034	1272	1590	3976	7952	15904	31808	47712	.0688
5	19.64	491	982	1277	1571	1964	4910	9820	19640	39280	58920	.0850
5 1/2	23.76	594	1188	1544	1901	2376	5940	11880	23760	47520	71280	.1028
7	38.49	962	1924	2502	3079	3849	9621	19243	38485	76970	115455	.1666
8	50.27	1257	2513	3267	4021	5027	12566	25133	50265	100530	150795	.2176
9	63.62	1590	3181	4135	5089	6362	15904	31809	63617	127234	190851	.2754
10	78.53	1964	3927	5105	6283	7854	19635	39270	78540	157080	235620	.3400

General Formula

The cylinder output forces are derived from the formula:

$$F = P \times A$$

Where F = Force in pounds.

P = Pressure at the cylinder in pounds per square inch, gauge.

A = Effective area of cylinder piston in square inches.

Operating Fluids and Temperature Range

Fluidpower cylinders are designed for use with pressurized air, hydraulic oil and fire resistant fluids, in some cases special seals are required.

Class 1 Seals

Class 1 seals are the standard seals provided in a cylinder assembly. They are intended for use with fluids such as: air, nitrogen, mineral base hydraulic oil or MIL-H-5606 within the temperature range of -10°F (-23°C) to +165°F (+74°C). The individual seals may be nitrile (Buna-N), enhanced polyurethane, polymyte, PTFE or filled PTFE.

Class 2 (Nitrile) Seals

Class 2 seals are intended for use with water base fluids within the temperature of -10°F (-23°C) to +165°F (+74°C) except for High Water Content Fluids (HWCF) in which case Class 6 seals should be used. Typical water base fluids compatible with Class 2 seals are: Water, Water-Glycol, Water-in Emulsion, Houghto-Safe 27, 620 5040, Mobil Pyrogard D, Shell Iruis 905, Ucon Hydrolube J-4. Class 2 seals are nitrile. Lipseal will have polymyte or PTFE back-up washer when required. O-rings will have nitrile back-up washers when required.

Class 3 Seals — Ethylene Propylene (E.P.R.) Seals

Class 3 seals are intended for use with some Phosphate Ester Fluids between the temperatures of -10°F (-23°C) to +130°F (+54°C). Typical fluids compatible with Class 3 seals are Skydrol 500 and 700. Class 3 seals are Ethylene Propylene. Lipseal will have a PTFE back-up washer when required. O-rings will have EPR back-up washers when required. Note: Class 3 seals are not compatible with mineral base hydraulic oil or greases. Even limited exposure to these fluids will cause severe swelling. PTFE back-up washer may not be suitable when used in a radiation environment.

Class 4 Seals — Nitrile Seals

Class 4 seals are intended for low temperature service with the same type of fluids as used with Class 1 seals within the temperature range of -50°F (-46°C) to +150°F (+66°C). Class 4 seals are nitrile seals. Lipseals will have leather, polymyte or PTFE back-up washers when required. O-rings will have nitrile back-up washers when required. Note: Certain fluids may react adversely with Class 4 seals compared to Class 1 seals.

Class 5 Seals — Fluorocarbon Seals

Class 5 seals are intended for elevated temperature service or for some Phosphate Ester Fluids such as Houghto-Safe 1010, 1055, 1120; Fryquel 150, 220, 300, 350; Mobil Pyrogard 42, 43, 53, and 55. Note: In addition, Class 5 seals can be used with fluids listed below under Class 1 or Class 2 service. However, they are not compatible with Phosphate Ester Fluids such as Skydrols. Class 5 seals can operate with a temperature range of -10°F (-23°C) to +250°F (+121°C). Fluorocarbon seals may be operated to +400°F (+204°C) with limited service life. For temperatures above +250°F (-121°C) the cylinder must be manufactured with non-studded piston rod thread and a pinned piston to rod connection. Class 5 seals are fluorocarbon seals. Lipseals will have PTFE back-up washers. O-rings will have fluorocarbon back-up when required.

Class 6 Seals

Class 6 seals are intended for High Water Content Fluids (HWCF) such as Houghton Hydrolubric 120B and Sonsol Lubrizol within the temperature range of +40°F (+4°C) to +120°F (+49°C). Class 6 seals are special nitrile compound dynamic seals. Lipseals will have PTFE and or polymyte back-up washers when required. O-rings will have nitrile back-up washers when required. Because of the viscosity of these fluids, cylinders specified with Class 6 seals, will also be modified to have lipseal piston seals and straight cushions.

Class 8 Seals – Spring Loaded PTFE Seals

Class 8 seals consist of PTFE piston lipseals, rod lipseal and wiper lipseal, each with an internal stainless steel spring to energize both the static and dynamic sealing lips. They are intended for high temperature applications, to 400° F (204° C), where longer seal life and improved high temperature sealing performance is required. Body and gland o-ring seals will be fluorocarbon. Fluid resistance is comparable to Class 5.

Hi-Load Seals

Hi-Load seals consist of one or two filled PTFE dynamic piston seals with an elastomer expander underneath. Hi-Load piston arrangement normally consists

of a wear ring on each end of the piston with the seals in the middle. These types of seals are virtually leak free seals under static conditions and can tolerate high pressure. The wear rings on the piston can also tolerate high side loads. The dynamic portion of the seal is bronze filled PTFE and compatible with all six classes of service. However, carbon filled PTFE will provide better seal life when used with Class 6 fluids. A nitrile expander will be provided unless Class 3 or 5 seals are specified. In those cases the expander will be of EPR or Fluorocarbon respectively. Note: It may be necessary to cycle the piston seals 40 or 50 times before achieving leakage free performance.

Lipseal Pistons

Lipseals with a back-up washers are standard in Series H cylinders and are often used for hydraulic applications when virtually zero static leakage is required. Lipseals will function properly in these applications when used in conjunction with moderate hydraulic pressures. A high load piston option is recommended when operating at high pressures and especially with large bore hydraulic cylinders.

Warning!

The piston rod stud and the piston rod to piston threaded connections are secured with an anaerobic adhesive which is temperature sensitive. Cylinders specified with fluorocarbon seals are assembled with anaerobic adhesive having a maximum temperature rating of +250°F (+121°C). Cylinders specified with all other seal compounds are assembled with anaerobic adhesive have a maximum operating temperature rating +165°F (+74°C). These temperature limitations are necessary to prevent the possible loosening of the threaded connections. Cylinders originally manufactured with Class 1 seals (Nitrile) that will be exposed to ambient temperatures above +165°F (+74°C) must be modified for higher temperature service. Contact the factory immediately and arrange for the piston to rod and the stud to piston rod connections to be properly reassembled to withstand the higher temperature service.

Low Friction Hydraulic Seals

Low Friction hydraulic seals are available as an option for both piston and piston rod seals for Series H cylinders. They are sometimes used when a cylinder is controlled by servo or proportional valve. The seal assembly itself is a two piece assembly consisting of a filled PTFE dynamic seal with an elastomer expander. A piston seal assembly consists of one seal assembly in the middle of the piston with a filled PTFE wear ring on each side of the piston. The piston rod seal assembly consists of two seal assemblies and an elastomer wiper seal. The filled PTFE seals are compatible with Class 1, 2, 3, 4 & 5 fluids and provide virtually leak free sealing. The expanders and rod wiper will be nitrile unless Class 3 or 5 seals are specified. In those cases the expanders and wiper will be EPR and fluorocarbon respectively. When specifying low friction seals specify if piston, piston rod seals or both are required. Note: It may be necessary to cycle these seals 40 or 50 times before achieving leakage free performance.

Cast Iron Piston Rings

Cast iron rings are optional piston seals for Series H cylinders. They offer the widest operating conditions by tolerating high operating pressures, wide temperature range and are compatible with most fluids. The only drawback of cast iron rings is that they allow a small amount of leakage. The leakage for a 4" bore cylinder, operating at 2000 psi, with mineral base hydraulic fluid will be less than 10in.³/min. Leakage will increase as pressure, bore size and viscosity of the operating hydraulic fluid increases. For these reasons cast iron rings are not recommended when using water or Class 6 fluids.

Water Service

Series H hydraulic cylinders can be modified for water operation and supplied with chrome-plated cylinder bore; electroless nickel-plated head, cap and piston; chrome-plated precipitation hardened stainless steel piston rod, chrome-plated cushion plungers. When high water base fluids are the operating medium, hydraulic cylinders are usually supplied with high water base rod wiper and seals. Water and high water base fluid operated cylinders are best used on short stroke applications or where high pressure is applied only to clamp the load.

Warranty

Atlas will warrant cylinders modified for water or high water content fluid service to be free of defects in materials or workmanship, but cannot accept responsibility to premature failure due to excessive wear due to lack of lubricity or where failure is caused by corrosion, electrolysis or mineral deposits within the cylinder.

Class No.	Typical Fluids	Temperature Range
1 Standard Nitrile Polyurethane	Air, Nitrogen Hydraulic Oil, Mil-H-5606 Oil	-10°F (-23°C) to +165°F (+74°C)
2 Optional Water base fluid seal	Water, Water-Glycol, HWCF — See Class 6 below. Water-in-Oil Emulsion Houghto-Safe, 271, 620, 5040 Mobil Pyrogard D, Shell Iruis 905 Ucon Hydrolube J-4	-10°F (-23°C) to +165°F (+74°C)
3 Special (EPR) (At extra cost) Note: Class 3 seals are not compatible with hydraulic oil.	Some Phosphate Ester Fluids Skydrol 500, 7000	-10°F (-23°C) to +130°F (+54°C)
4 Special (Nitrile) (At extra cost)	Low Temperature Air or Hydraulic Oil	-50°F (-46°C) to +150°F (+66°C)
5 Optional (At extra cost) (Fluorocarbon Seals) Note: Class 5 seals are not suitable for use with Skydrol fluid, but can be used with hydraulic oil if desired	High Temperature Houghto-Safe 1010, 1055, 1120 Fryquel 150, 220, 300, 550 Mobil Pyrogard 42,43,53,55	See above paragraph on Fluorocarbon seals for recommended temperature range.
6 Optional (HWCF) (At extra cost)	Houghton, Hydrolubric 120B Sonsol Lubrizol, for other HWCF — consult factory.	+40°F (+4°C) to +120°F (+49°C)
8 Optional (At extra cost) Spring Loaded PTFE	See Class 5 Seals	-15°F (-26°C) to 400°F (204°C)

Application Data

The proper application of a fluid power cylinder requires consideration of the operating pressure, the fluid medium, the mounting style, the length of stroke, the type of piston rod connection to the load, thrust or tension loading on the rod,

mounting attitude, the speed of stroke, and how the load in motion will be stopped. Information given here provides pressure rating data for Series H hydraulic cylinders.

Pressure Ratings

Standard operating fluid — clean, filtered hydraulic oil. Pressure ratings for heavy-duty hydraulic cylinders are shown in the table.

Series H hydraulic cylinders are recommended for pressures to 3000 psi for heavy-duty service with hydraulic oil. The 4:1 design factor ratings shown are based on tensile strength of material and are for standard rod diameter only. The rating is conservative for continuous severe applications. Design factors at other pressures can be calculated from this rating. In addition, mounting styles, stroke, etc., should be considered because of the limiting effect they may have on these ratings.

**Series H Hydraulic Cylinders
Maximum Pressure Ratings**

Bore Size (Inches)	Rod Diameter (Inches)	4:1* Design Factor (Tensile)(PSI)	Heavy-Duty Service (PSI)
1½	5/8	2530	3000
2	1	2950	3000
2½	1	2340	3000
3¼	1¾	2250	3000
4	1¾	2130	3000
5	2	2170	3000
6	2½	2270	3000
7	3	2030	3000
8	3½	2040	3000
10	4½	2720	3000
12	5½	2580	3000
14	7	2320	3000
16	8	2750	3000
18	9	2900	3000
20	10	2640	3000

* Applies to all mountings except Styles REF1, REF2, BEF2, TM1, TM2, TM3.

Cylinder Weights

To determine the net weight of a cylinder, first select the proper basic weight for zero stroke, then calculate the weight of the cylinder stroke and add the result to the basic weight. For extra rod extension use piston rod weights per inch shown in Table B. Weights of cylinders with intermediate

rods may be estimated from table below by taking the difference between the piston rod weights per inch and adding it to the standard rod diameter weight for the cylinder bore size involved.

Table A Cylinder Weights, in pounds

Bore Size	Rod Dia.	Single Rod Cylinders Basic Wt. Zero Stroke		Add Per Inch of Stroke	Double Rod Cylinders Basic Wt. Zero Stroke		Add Per Inch of Stroke
		FS, BEF2, BEF1, REF2, REF1, NM0, NM1, NM2, NM3	PB2, SL, TM1, TM2, TM3, CL, ME6, ME5		FS, REF2, REF1, NM0, NM3	SL, TM1, TM3, CL, ME5	
1 1/2"	5/8"	7.8	9.0	.5	9.1	10.7	.6
	1"	8.4	9.3	.6	9.7	10.8	.8
2"	1"	11.6	13.2	.8	14.6	16.8	1.0
	1 3/8"	13.5	17.1	1.0	19.4	20.6	1.4
2 1/2"	1"	17.0	19.5	1.1	21.0	24.5	1.3
	1 3/4"	22.5	25.5	1.5	27.0	30.0	2.2
3 1/4"	1 3/8"	32.0	41.0	1.8	43.0	52.0	2.2
	2"	37.0	46.0	2.2	48.0	57.0	3.1
4"	1 3/4"	48.0	53.0	2.5	59.0	63.0	3.2
	2 1/2"	52.0	58.0	3.2	92.0	97.0	4.6
5"	2"	76.0	82.0	3.4	96.0	102.0	4.8
	3 1/2"	88.0	86.0	5.2	117.0	123.0	7.9
6"	2 1/2"	125.0	133.0	5.2	153.0	159.0	6.6
	4"	133.0	140.0	7.3	182.0	190.0	10.9
7"	3"	233.0	242.0	6.7	320.0	339.0	8.7
	5"	240.0	253.0	10.3	341.0	360.0	15.9
8"	3 1/2"	262.0	276.0	9.0	323.0	331.0	11.7
	5 1/2"	300.0	309.0	13.0	390.0	411.0	19.7

Bore Size	Rod Dia.	Single Rod Cylinders Basic Wt. Zero Stroke				Add Per Inch of Stroke	Double Rod Cylinders Basic Wt. Zero Stroke	
		TM1, TM2	TM3, ME5, ME6	IH3, IH4	PB2, SL, CL		Add to All Mtg. Styles	Add Per Inch of Stroke
10"	4 1/2"	562	646	684	607	15	43	20
	7"	620	704	742	665	21	101	32
12"	5 1/2"	924	1057	1136	1000	22	64	29
	8"	1022	1155	1234	1097	29	162	43
14"	7"	1335	1520	1582	1485	28	101	39
	10"	1496	1681	1743	1646	39	262	61

Table B Piston Rod Weights, in pounds

Rod Dia.	Rod Wt. Per Inch	Rod Dia.	Rod Wt. Per Inch	Rod Dia.	Rod Wt. Per Inch	Rod Dia.	Rod Wt. Per Inch
5/8"	.09	2"	.89	4"	3.56	7"	10.89
1"	.22	2 1/2"	1.40	4 1/2"	4.51	8"	14.22
1 3/8"	.42	3"	2.00	5"	5.56	10"	22.23
1 3/4"	.68	3 1/2"	2.72	5 1/2"	6.72		

Ports

Series H cylinders can be supplied with SAE straight O-ring ports or NPTF pipe thread ports. If specified on your order, extra ports can be provided on the sides of heads or caps that are not occupied by mountings or cushion valve.

Standard port location is position 1 as shown on line drawings in product catalog and Figure 1 below. Cushion adjustment needle and check valves are at positions 2 and 4 (or 3), depending on mounting style. Heads or caps which do not have an integral mounting can be rotated and assembled with ports at 90° or 180° from standard position. Mounting styles on which head or cap can be rotated at no extra charge are shown in Table A below. To order, specify by position number. In such assemblies the cushion adjustment needle and check valve rotate accordingly since their relationship with port position does not change.

Figure 1

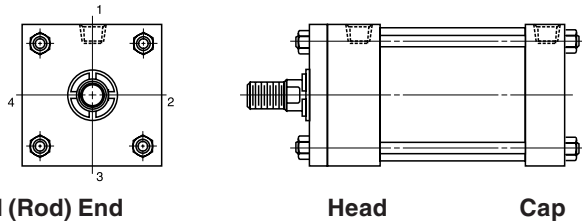

Head (Rod End)

Head

Cap

Table A

Mounting Style	Port Position Available	
	Head End	Cap End
NM1, NM2, NM3, REF2, BEF2, REF1, BEF1, TM3	1, 2, 3 or 4	1, 2, 3 or 4
ME6, TM2, PB2, SA	1,2, 3 or 4	1 or 3
ME5, TM1	1 or 3	1, 2, 3 or 4
SL, FS	1	1

Ports can be supplied at positions other than those shown in Table A at an extra charge. To order, specify port position as shown in Figure 1.

Straight Thread Ports

The SAE straight thread O-ring port is recommended for hydraulic applications. Atlas will furnish this port configuration at positions shown in Table A. This port can also be provided at positions other than those shown in Table A at an extra charge. SAE port size numbers are listed next to the NPTF pipe thread counterparts for each bore size in the respective product catalogs. Size number, tube O.D., and port thread size for SAE ports are listed in Table B.

Table D – Standard Port Sizes

Bore	S SAE	N NPTF	F SAE Code 61 Flange	I ISO 6149	BSPT BSPP	Metric
1 1/2	#8	1/2	N/A	M22 x 1.5	1/2	M22 x 1.5
2	#8	1/2	N/A	M22 x 1.5	1/2	M22 x 1.5
2 1/2	#8	1/2	1/2*	M22 x 1.5	1/2	M22 x 1.5
3 1/4	#12	3/4	3/4	M27 x 2	3/4	M27 x 2
4	#12	3/4	3/4	M27 x 2	3/4	M27 x 2
5	#12	3/4	3/4	M27 x 2	3/4	M27 x 2
6	#16	1	1	M33 x 2	1	M33 x 2

Table B

SAE Straight Thread O-Ring Ports

Size No.	Tube O.D. (In.)	Thread Size	Size No.	Tube O.D. (In.)	Thread Size
2	1/8	5/16 - 24	12	3/4	1 1/16 - 12
3	3/16	3/8 - 24	—	—	—
4	1/4	7/16 - 20	16	1	1 5/16 - 12
5	5/16	1/2 - 20	20	1 1/4	1 5/8 - 12
6	3/8	9/16 - 18	24	1 1/2	1 7/8 - 12
8	1/2	3/4 - 16	32	2	2 1/2 - 12
10	5/8	7/8 - 14	—	—	—

Note: For the pressure ratings of individual connectors, contact your connector supplier. Hydraulic cylinders applied with meter out or deceleration circuits are subject to intensified pressure at the cylinder piston rod end. The rod end pressure is approximately equal to:

$$\frac{\text{Effective Cap End Piston Area}}{\text{Effective Rod End Piston Area}} \times \text{Operating Pressure}$$

International Ports

Other port configurations to meet international requirements are available at extra cost. Atlas Series H cylinders can be supplied, on request, with British standard taper port (BSPT). Such port has a taper of 1 in 16 measured on the diameter (1/16" per inch). The thread form is Whitworth System, and size and number of threads per inch are as follows:

Table C

British Standard Pipe Threads

Nominal Pipe Size	No. Threads Per Inch	Pipe O.D.
1/8	28	.383
1/4	19	.518
3/8	19	.656
1/2	14	.825
3/4	14	1.041
1	11	1.309
1 1/4	11	1.650
1 1/2	11	1.882
2	11	2.347

British standard parallel internal threads are designated as BSPP and have the same thread form and number of threads per inch as the BSPT type and can be supplied, on request, at extra cost. Unless otherwise specified, the BSPP or BSPT port size supplied will be the same nominal pipe size as the NPTF port for a given bore size cylinder.

Metric ports can also be supplied to order at extra cost. See table below for standard port size for each bore.

Bore	S SAE	N NPTF	F SAE Code 61 Flange	I ISO 6149	BSPT BSPP	Metric
7	#20	1 1/4	1 1/4	M42 x 2	1 1/4	M42 x 2
8	#24	1 1/2	1 1/2	M48 x 2	1 1/2	M48 x 2
10	#24	1 1/2	2	M48 x 2	1 1/2	M48 x 2
12	#24	1 1/2	2 1/2	M48 x 2	1 1/2	M48 x 2
14	#24	1 1/2	1 1/2	M48 x 2	1 1/2	M48 x 2
16-20	#24	—	3	—	—	—

*Available with 1 inch rod diameter only.

Oversize Ports

Oversize NPTF or SAE straight thread ports can be provided, at an extra charge. For ports one size larger than standard, welded port bosses which protrude from the side of the head or cap are supplied. For dimensions, see drawings and tables below. Series H cylinders equipped with cushions at the cylinder cap end can sustain damage to the cushion check valve (cushion bushing) if excessive oil flow enters the cylinder from the cap end port. Cylinders which are equipped with cap end cushions and ordered with one size oversize ports having hydraulic fluid flow exceeding 25 ft./sec. in the line entering the cap end of the cylinder should be ordered with a "solid cushion" at cap end. All cylinders ordered with double oversize ports should always be ordered with a "solid cushion" at cap end.

Cylinders which are connected to a meter out flow control with flow entering the cap end of a cylinder provided by an accumulator may also experience damage to the cushion bushing due to high instantaneous fluid flows. This condition can be eliminated by using a meter in flow control or "solid cushions" at cap end.

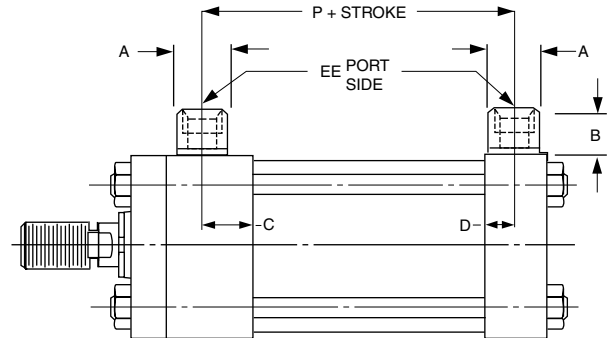

Oversize NPTF Port Boss Dimensions

Bore	EE (NPTF)	A (Dia.)	B	C	D	P
1 1/2	3/4	1 3/8	1	3/4	25/32	2 29/32
2	3/4	1 3/8	1	3/4	25/32	2 29/32
2 1/2	3/4	1 3/8	1	3/4	25/32	3 1/32
3 1/4	1	1 3/4	1 3/16	29/32	7/8	3 17/32
4	1	1 3/4	1 3/16	29/32	7/8	3 25/32
5	1	1 3/4	1 3/16	29/32	7/8	4 9/32
6	1 1/4	2 1/4	1 5/16	1 1/8	1 1/8	5 1/8
7	1 1/2	2 1/2	1 9/16	1 3/8	1 3/8	5 3/4
8	2	3	1 11/16	1 1/2	1 1/2	6 1/2

Oversize SAE Straight Thread Port Boss Dimensions

Bore	EE (SAE)	A (Dia.)	B	C	D	P
1 1/2	10*	-	-	-	-	2 7/8
2	10*	-	-	-	-	2 7/8
2 1/2	10*	-	-	-	-	3
3 1/4	16	1 3/4	1 3/16	7/8	7/8	3 7/16
4	16	1 3/4	1 3/16	7/8	7/8	3 11/16
5	16	1 3/4	1 3/16	7/8	7/8	4 3/16
6	20*	-	-	-	-	5 3/16
7	24*	-	-	-	-	5 1/2
8	N/A	-	-	-	-	6 1/4

* Port tapped directly into head and cap.

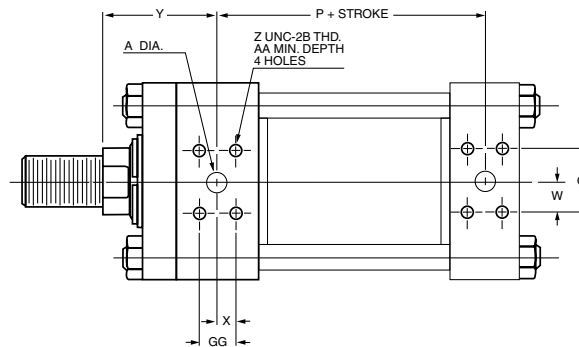

Flange Ports (Code 61, 3000 psi) SAE 4 Bolt Flange Ports

Bore Size	SAE Dash No.	Y	A	P	Q	W	X
2 1/2†*	8	2.39	.50	2.97	1.50	.75	.34
3 1/4†	12	2.80	.75	3.41	1.87	.94	.44
		3.17					
4†	12	3.05	.75	3.66	1.87	.94	.44
		3.42					
5†	12	3.17	.75	4.16	1.87	.94	.44
		3.42					
		3.42					
6	16	3.52	1.00	4.58	2.06	1.03	.52
7	20	3.70	1.25	5.59	2.31	1.16	.59
8	24	3.84	1.50	6.31	2.75	1.37	.70

Bore Size	SAE Dash No.	Z	AA	GG
2 1/2†	8	5/16 - 18	.81	.69
3 1/4†	12	3/8 - 16	.75	.87
4†	12	3/8 - 16	.75	.87
5†	12	3/8 - 16	.75	.87
6	16	3/8 - 16	.87	1.03
7	20	7/16 - 14	1.00	1.19
8	24	1/2 - 13	1.06	1.41

† 2 1/2", 3 1/4", 4" & 5" bores cap-flange port not available on Style BEF1.

Style BEF2 not available at position 2 or 4. Port flange overhangs cap on Style ME6.

* 2 1/2" bore head flange port available with 1" and 1 3/8" rod only.

Stroke Data

Atlas cylinders are available in any practical stroke length. The following information should prove helpful to you in selecting the proper stroke for your cylinder application.

Stroke Tolerances

Stroke length tolerances are required due to buildup of tolerances of piston, head, cap and cylinder tube. Standard production stroke tolerances run $+1/32"$ to $-1/64"$ up to 20" stroke, $+1/32"$ to $-.20"$ for 21" to 60" and $+1/32"$ to $-1/32"$ for greater than 60" stroke. For closer tolerances on stroke length, it is necessary to specify the required tolerance plus the operating pressure and temperature at which the cylinder will operate. Stroke tolerances smaller than .015" are not generally practical due to elasticity of cylinders. If machine design requires such close tolerances, use of a stroke adjuster (below) may achieve the desired result.

Tie Rod Supports

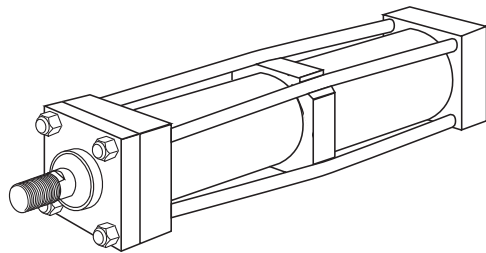

Rigidity of Envelope

The prestressed tie rod construction of cylinders has advantages in rigidity within the limits of the cylinder tube to resist buckling. For long stroke cylinders within practical limits. Tie rod supports (see table below) which move the tie rod centerlines radially outward (patent number 3011844) are used.

Standard tie rod supports are kept within the envelope dimensions of the head and cap, and generally do not interfere with mounting a long cylinder.

Number of Supports Required	Stroke (Inches)												
	Bore	36	48	60	72	84	96	108	120	132	144	156	168
1 1/2	—	—	1	1	1	2	2	2	3	3	3	3	4
2	—	—	—	1	1	1	1	2	2	2	2	2	3
2 1/2	—	—	—	—	—	—	1	1	1	1	1	2	2
3 1/4	—	—	—	—	—	—	—	—	1	1	1	1	1
4	—	—	—	—	—	—	—	—	—	—	1	1	1

Note: 5" through 8" bore sizes — no supports required.

Stroke Adjusters

Where absolute precision in stroke length is required, a screwed adjustable stop can be supplied. Several types are available – the illustration shows a design suitable for infrequent* adjustment at the uncushioned cap end of a cylinder. Please contact the factory, specifying details of the application and the adjustment required.

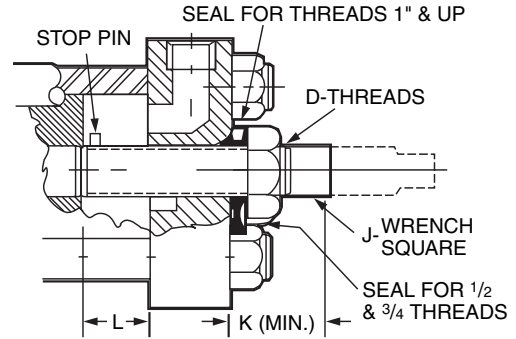

Bore Size	D	J	K	L (Max.)
1 1/2	1/2 - 20	5/16	15/16	5
2	3/4 - 16	7/16	1 1/4	8
2 1/2, 3 1/4	1 - 14	5/8	1 11/16	9
4	1 1/2 - 12	15/16	2 1/8	18
5	2 - 12	1 5/16	2 11/16	20
6	2 1/2 - 12	1 11/16	3 1/8	20
7	3 - 12	2	3 1/4	20
8	3 1/2 - 12	2 3/8	3 1/2	20

* Infrequent is defined by positioning the retract stroke in a couple of attempts at original machine set-up. The frequent stroke adjuster is recommended when adjustments may be required by the end user.

Stop Tubing

Stop tube is recommended to lengthen the distance between the rod bearing and piston to reduce bearing loads when the cylinder is fully extended. This is especially true of horizontally mounted and long stroke cylinders. Long stroke cylinders achieve additional stability through the use of a stop tube.

Drawing A

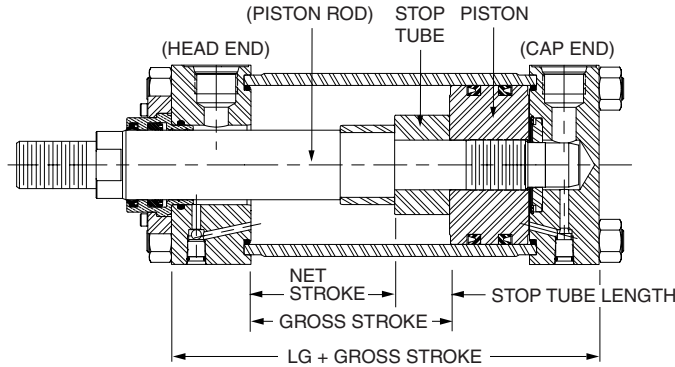

When specifying cylinders with long stroke and stop tube, be sure to call out the net stroke and the length of the stop tube. Machine design can be continued without delay by laying in a cylinder equivalent in length to the NET STROKE PLUS STOP TUBE LENGTH, which is referred to as GROSS STROKE.

Drawing B

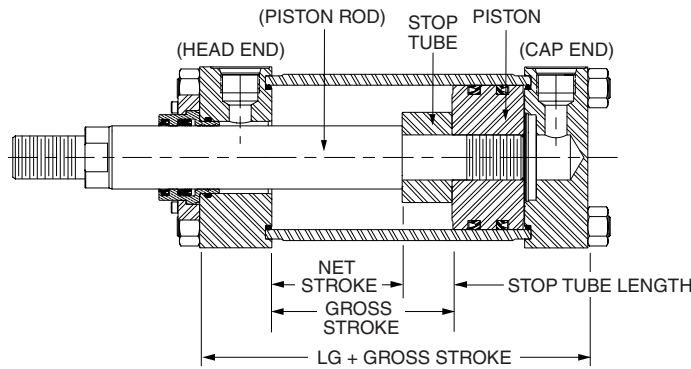

This design is supplied on all non-cushion cylinders.

Mounting Classes

Standard mountings for fluid power cylinders fall into three basic groups. The groups can be summarized as follows:

Group 1 Straight Line Force Transfer with fixed mounts which absorb force on cylinder centerline.

Group 2 Pivot Force Transfer. Pivot mountings permit a cylinder to change its alignment in one plane.

Group 3 Straight Line Force Transfer with fixed mounts which do not absorb force on cylinder centerline.

Because a cylinder's mounting directly affects the maximum pressure at which the cylinder can be used, the chart below should be helpful in selection of the proper mounting combination for your application. Stroke length, piston rod connection to load, extra piston rod length over standard, etc., should be considered for thrust loads. Alloy steel mounting bolts are recommended for all mounting styles, and thrust keys are recommended for Group 3.

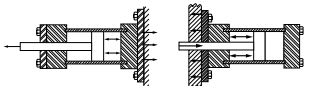
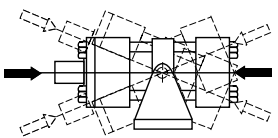
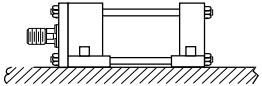
Group 1 FIXED MOUNTS which absorb force on cylinder centerline.	
<p>Heavy-Duty Service For Thrust Loads For Tension Loads</p>	 <p>Styles NM2, BEF1, ME6 Styles NM3, REF1, ME5</p>
<p>Medium-Duty Service For Thrust Loads For Tension Loads</p>	<p>Styles BEF1, BEF2 Styles REF1, REF2</p>
<p>Light-Duty Service For Thrust Loads For Tension Loads</p>	<p>Style BEF2 Style BEF1</p>
Group 2 PIVOT MOUNTS which absorb force on cylinder centerline.	
<p>Heavy-Duty Service For Thrust Loads For Tension Loads</p>	 <p>Styles TM1, TM3 Styles TM1, TM2, PB2, TM3</p>
<p>Medium-Duty Service For Thrust Loads For Tension Loads</p>	<p>Style PB2 Style PB2</p>
Group 3 FIXED MOUNTS which do not absorb force on the centerline.	
<p>Heavy-Duty Service For Thrust Loads For Tension Loads</p>	 <p>Style SL Style SL</p>
<p>Medium-Duty Service For Thrust Loads For Tension Loads</p>	<p>Style FS Style FS</p>

How to Use the Chart

The selection of a piston rod for thrust (push) conditions requires the following steps:

1. Determine the type of cylinder mounting style and rod end connection to be used. Then consult the chart below and find the "stroke factor" that corresponds to the conditions used.

2. Using this stroke factor, determine the "basic length" from the equation:

$$\text{Basic Length} = \frac{\text{Actual Stroke}}{\text{Stroke Factor}}$$

The graph is prepared for standard rod extensions beyond the face of the rod gland retainers. For rod extensions greater than standard, add the increase to the stroke in arriving at the "basic length."

3. Find the load imposed for the thrust application by multiplying the full bore area of the cylinder by the system pressure.
4. Enter the graph along the values of "basic length" and "thrust" as found above and note the point of intersection:
 - A) The correct piston rod size is read from the diagonally curved line labeled "Rod Diameter" next *above* the point of intersection.
 - B) The required length of stop tube is read from the right of the graph by following the shaded band in which the point of intersection lies.

- C) If required length of stop tube is in the region labeled "consult factory," submit the following information for an individual analysis:
 - 1) Cylinder mounting style.
 - 2) Rod end connection and method of guiding load.
 - 3) Bore, required stroke, length of rod extension (Dim. "LA") if greater than standard, and series of cylinder used.
 - 4) Mounting position of cylinder. (Note: If at an angle or vertical, specify direction of piston rod.)
 - 5) Operating pressure of cylinder if limited to less than standard pressure for cylinder selected.

Warning 

Piston rods are not normally designed to absorb bending moments or loads which are perpendicular to the axis of piston rod motion. These additional loads can cause the piston rod end to fail. If these types of additional loads are expected to be imposed on the piston rods, their magnitude should be made known to our Engineering Department so they may be properly addressed. Additionally, cylinder users should always make sure that the piston rod is securely attached to the machine member.

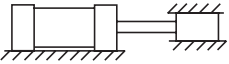
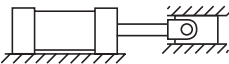
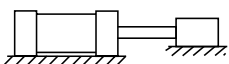
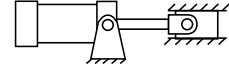
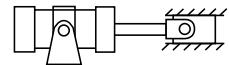
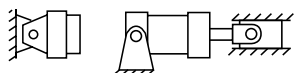
Recommended Mounting Styles for Maximum Stroke and Thrust Loads	Rod End Connection	Case	Stroke Factor
<p>Groups 1 or 3 Long stroke cylinders for thrust loads should be mounted using a heavy-duty mounting style at one end, firmly fixed and aligned to take the principal force. Additional mounting should be specified at the opposite end, which should be used for alignment and support. An intermediate support may also be desirable for long stroke cylinders mounted horizontally. See "Tie Rod Supports — Rigidity of Envelope" for a guide. Machine mounting pads can be adjustable for support mountings to achieve proper alignment.</p>	Fixed and Rigidly Guided	I 	.50
	Pivoted and Rigidly Guided	II 	.70
	Supported but not Rigidly Guided	III 	2.00
<p>Group 2 Style TM1 — Trunnion on Head</p>	Pivoted and Rigidly Guided	IV 	1.00
<p>Style TM3 — Intermediate Trunnion</p>	Pivoted and Rigidly Guided	V 	1.50
<p>Style TM2 — Trunnion on Cap or Style PB2 — Clevis on Cap</p>	Pivoted and Rigidly Guided	VI 	2.00

Piston Rod — Stroke Selection Chart

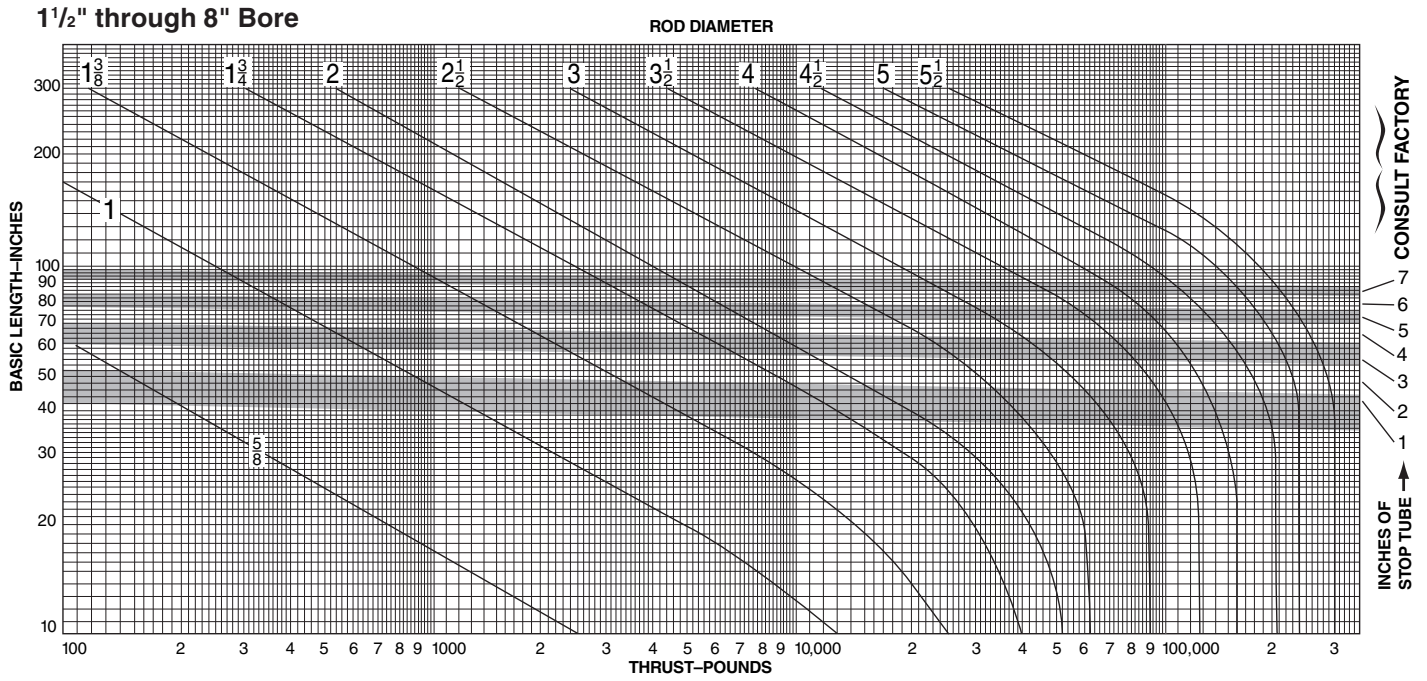

Piston Rod — Stroke Selection Chart

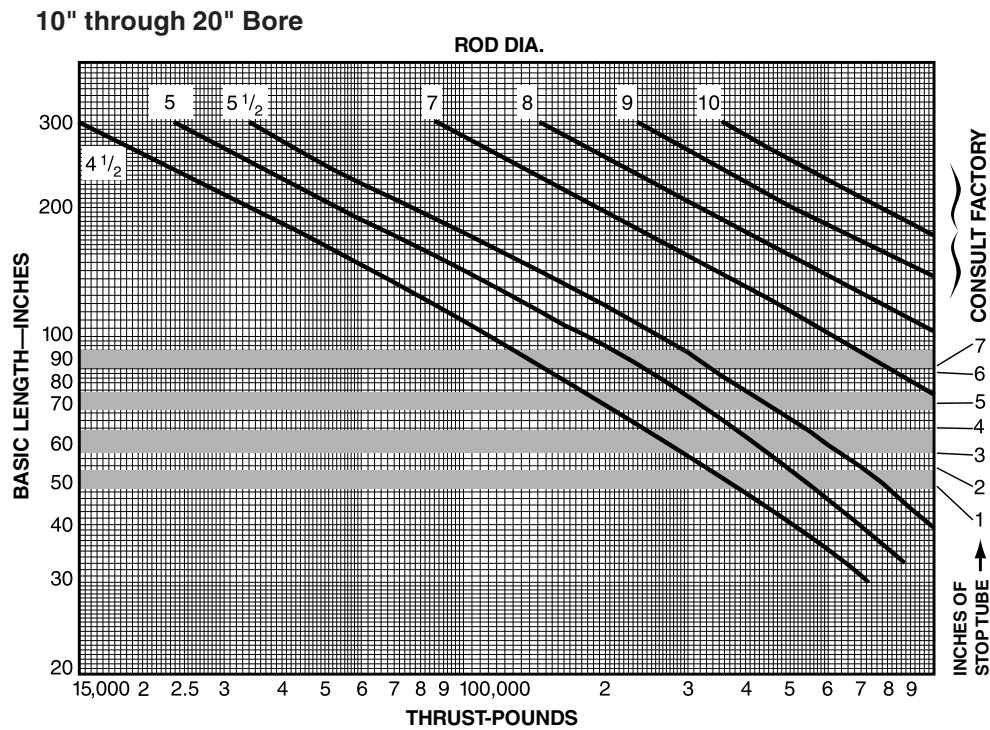

Rod Gland Drain

Rod gland drains permit capture of fluid that may accumulate between the primary rod seal and the wiperseal. A 1/8 NPTF port is provided in the gland retainer or cylinder head (see table below) for connection of plumbing that flows oil back to the reservoir. Use of translucent tubing as the drain to reservoir line can provide visual indication of a need for rod seal service when the cylinder gland is not easily visible within the equipment. Specify rod gland drain port option and the drain port location, position 1, 2, 3, or 4.

Drain Port Location

Bore	Rod Dia.	NM2, BEF1, BEF2, ME6, SL, FS, TM1, TM2, PB2, TM3, SA	NM1, NM3, REF1, REF2	ME5
1 1/2	5/8	Head	Head	Head
	1	Full Retainer	Full Retainer	Head
2	1	Bolted Retainer	Full Retainer	Head
	1 3/8	Full Retainer	Full Retainer	Head
2 1/2	1 - 1 3/8	Bolted Retainer	Head	Head
	1 3/4	Bolted Retainer	Full Retainer	Head
3 1/4	All	Bolted Retainer	Head	Head
4	All	Bolted Retainer	Head	Head
5	2 - 3	Bolted Retainer	Head	Head
	3 1/2	Bolted Retainer	Full Retainer	Head
6 - 8	All*	Bolted Retainer	Head	Head

* On 5 1/2" diameter piston rods, with drain in position 2 or 4, the port will be offset 18 degrees clockwise from the position specified.

Note: When a key retainer and rod gland drain are specified the port location will be the same as mounting styles NM1, NM3, etc.

The full square retainer, key retainer, or mounting flange thickness is increased on three bore and rod combinations. The piston rod is extended on NM1, NM3, REF1, and REF2 mounts to provide the standard 'W' dimension.

Bore	Rod Dia.	Retainer or Mounting Flange Thickness
1 1/2	1	5/8
2	1 3/8	3/4
2 1/2	1 3/4	7/8

Thrust Key Mountings

Thrust key mountings eliminate the need of using fitted bolts or external keys on side mounted cylinders. Cylinder Styles SL and FS can be provided with the gland retainer plate extended below the mounting side of the cylinder (see illustration below). This extended retainer plate can then be fitted into a keyway milled into the mounting surface of the machine member.

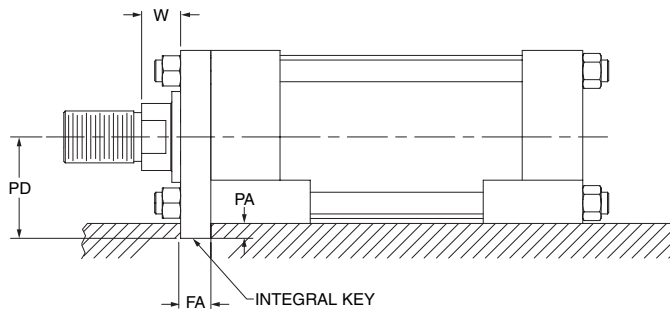

Bore	+0.000" -0.001" Dim. FA	Dim. PA	Dim. PD Styles SL, FS
1 1/2	.361	3/16	1 7/16
2	.611	5/16	1 13/16
2 1/2	.611	5/16	2 1/16
3 1/4	.736	3/8	2 5/8
4	.861	7/16	2 15/16
5	.861	7/16	3 1/16
6	.986	1/2	4 1/4
8	.986	1/2	5 1/4

End of Stroke Magnetic Principle Type Proximity Switch

Reliable: Proximity type sensor never contacts cylinder moving parts; eliminating wear and adjustments.

Positive Action: Multiple magnet design provides "snap action." Eliminates creep and false signals.

Versatile: Sealed stainless steel switch body can be used with any operating fluid and is impervious to most environmental conditions.

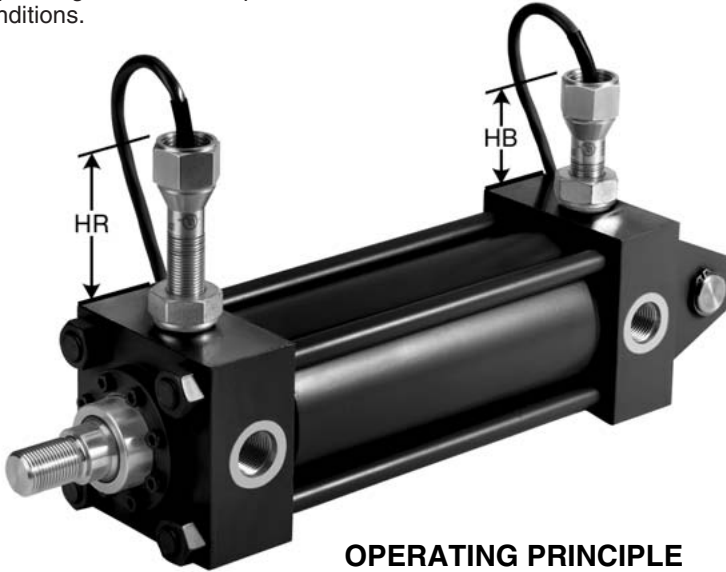

Switch Extension in Inches

Bore	Rod Dia.	HR	HB
1 1/2	5/8	3 7/16	3 1/4
	1	3 5/8	
2	1	3 7/16	3
	1 3/8	3 5/8	
2 1/2	1	3 1/4	2 3/4
	1 3/8	3 7/16	
	1 3/4	3 5/8	
3 1/4	1 3/8	2 15/16	2 1/2
	1 3/4	3 1/8	
	2	3 5/16	
4	1 3/4	2 7/8	2 7/16
	2	3 1/16	
	2 1/2	3 3/8	
5	2	2 1/4	3 1/4
	2 1/2	2 5/8	
	3	2 7/8	
	3 1/2	3 1/8	
6	2 1/2	2 1/8	2 15/16
	3	2 3/8	
	3 1/2	2 5/8	
	4	2 7/8	
7	3	3 3/8	2 5/8
	3 1/2	2 1/8	
	4	2 3/8	
	5	2 15/16	
8	3 1/2	3 1/8	2 1/4
	4	3 3/8	
	5	3 5/8	
	5 1/2	2 5/8	

OPERATING PRINCIPLE

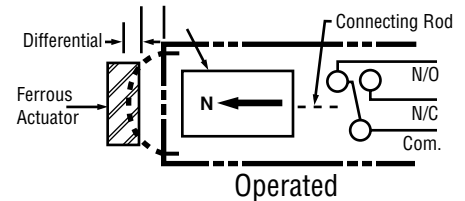
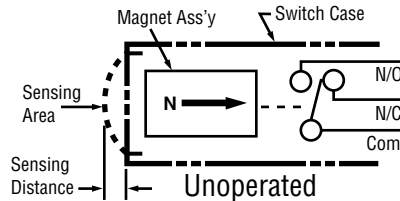

Switch Options

- Quick disconnect.
- Explosion proof.
- Sub sea, to 2000 feet depths.
- Extra-long leads.

As shown in the sketches above, these switches are magnetically operated. Dual magnets provide a dependable "snap action" for positive position sensing.

In the "unoperated" position, the magnet assembly is attracted in the direction of the arrow, causing a finely ground stainless steel connecting rod to hold the contacts open.

In the "operated" position a ferrous part (cushion or piston) enters the sensing area and attracts the magnet assembly which causes the rod to draw the contacts closed.

How to Order:

To order switches, enter an "S" in the Options field of the cylinder model code. Describe the modification in notes by specifying:

- Magnaswitch
- Installation in head, cap, or both ends of the cylinder
- Location in the head or cap (position #1, 2, 3, or 4) not occupied by a port or mounting

Specifications

Switch Type:
Magnetic Principle

Contacts:
Single Pole-Double Throw (SPDT)

Contact Rating*:
2 Amp at 110-240 VAC (UL & CSA)
100 MA at 12 VDC 50 MA at 24 VDC (CSA)

Note: Check current draw of solenoid valves.

Connection: 36" long, 3 wire, potted in cable. Can be wired Normally Open or Normally Closed. Leads are tagged (Com, N/O, N/C)

Pressure Rating: 3000 PSI
Non Shock

Temperature Range:
-20°F to +200°F (UL 104°F. Max.)

Sensing Gap:
.030 to .060 inch

Trip Point: Factory Set with Piston Bottomed out

Release Point: Approximately 1/4" Piston Travel

Min. Cyl. stroke 1/2" on 1 1/2" & 2" bore, 3/4" stroke on 2 1/2" and up.

*UL and CSA approved for industrial control, general purpose use. If Class I, Division 1 or 2 is required, please specify.

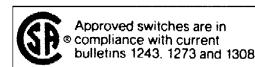

1 1/2" through 6" Bore Sizes

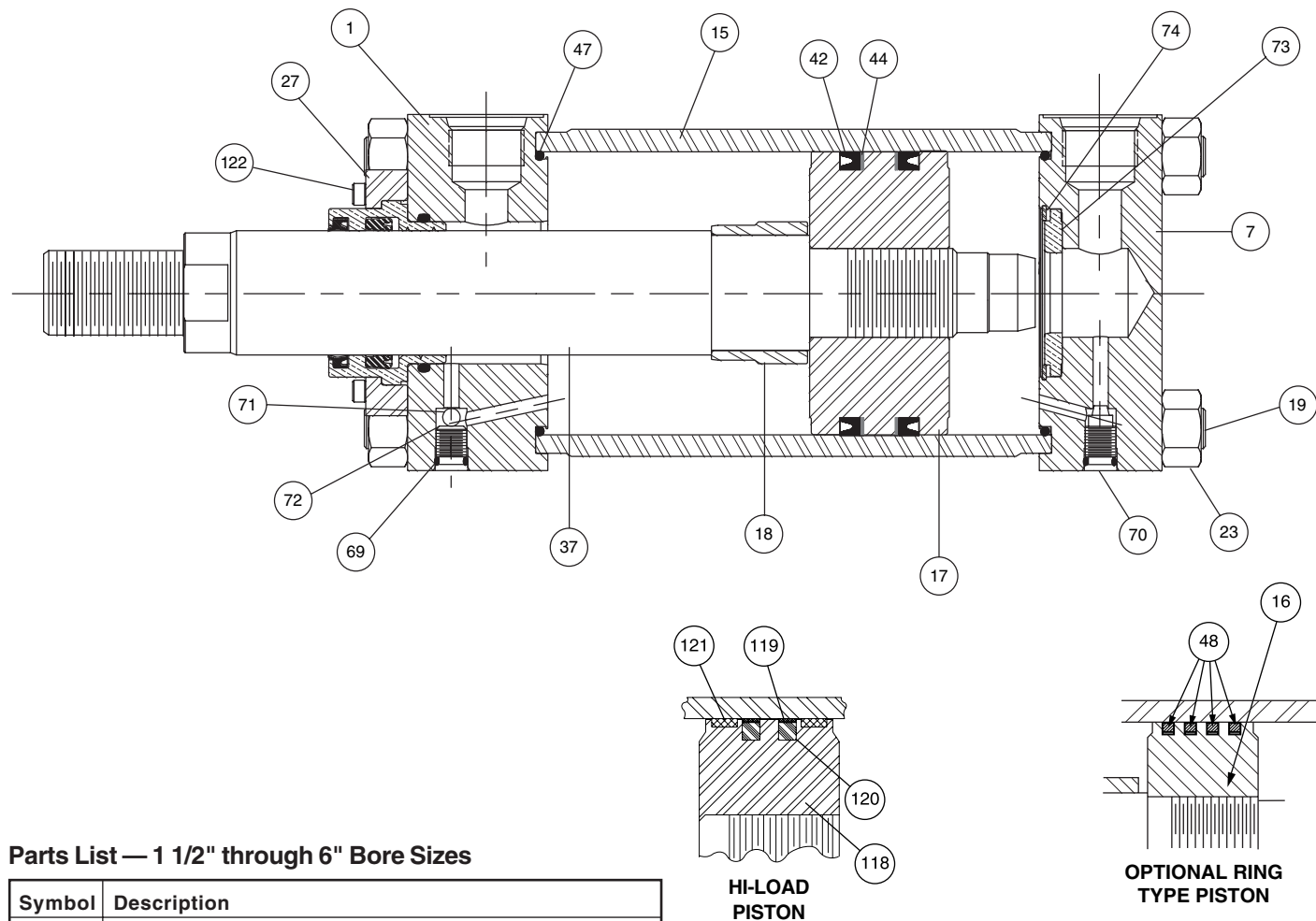

Parts List — 1 1/2" through 6" Bore Sizes

Symbol	Description
1	Head
7	Cap
15	Cylinder tube
16	Piston, ring type
17	Piston, lipseal type
18	Cushion plunger, rod head cushion
19	Tie rod
23	Tie rod nut
27	Retainer
37	Piston rod, single rod type
42	Lipseal, piston
44	Back-up washer, piston
47	O-ring, cylinder tube to head and cap seal
48	Piston ring, iron
69	O-ring, cushion adjustment and check valve plug screw
70	Needle, cushion adjustment valve
71	Ball, cushion check valve
72	Plug screw, cushion check valve
73	Bushing, float check, cushion on cap end
74	Retaining ring, float check cushion bushing
118	Piston, Hi-Load type
119	Outer Ring
120	Inner Ring
121	Wear Ring
122	Retainer bolt

Piston and Rod Assemblies

Factory assembled piston and rod assemblies (that include seals for piston type specified) are recommended.

1 1/2" through 6" Bore Sizes

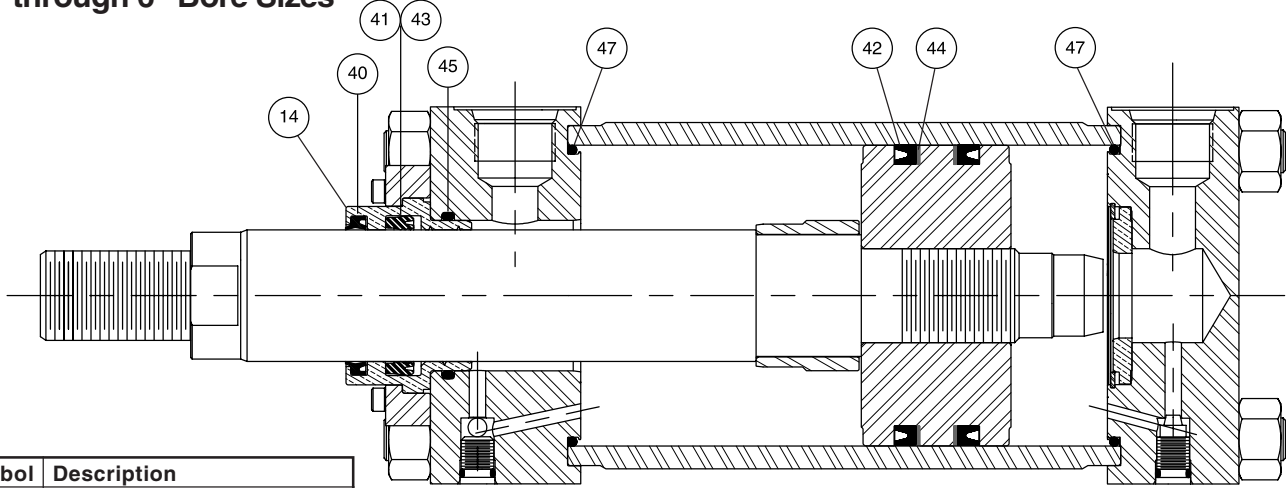

Symbol	Description
14	Rod Gland
40	Rod Wiper
41	Rod Seal
42	Piston Lipseal
43	Rod Seal Back-up Washer
44	Piston Seal Back-up Washer
45	Gland to head o-ring
47	End seal o-ring
48	Piston ring
119	Outer Ring
120	Inner Ring
121	Wear Ring

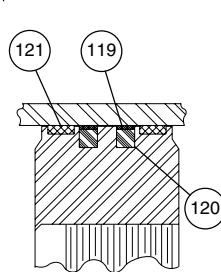

HI-LOAD PISTON

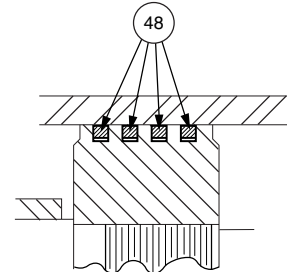

OPTIONAL RING TYPE PISTON

Seal Kits

See [Operating Fluids and Temperature Range Page](#) for compatibility.

Piston Seal Kits

Bore Size	Class 1 & 2 Buna-N				
	Piston Lipseal Kits (Contains: 2 Each Sym. #42, 44, & 47)	Piston Ring Kits (Contains: 4 Each Sym. #48 & 2 Each Sym. #47)	Hi-Load Piston Seal Kits (Contains: 2 Each Sym. #47, 119, 120, & 121)	Poly Flex Piston Seal Kits (Contains: 2 Each Sym. #42, 44, & 47)	Tie Rod Nut Specification Foot Lbs.* (-0%, +5% tolerance)
1 1/2	PH00LH015	PH00CH015	PH00KH015	UH00MH015	18
2	PH00LH020	PH00CH020	PH00KH020	UH00MH020	45
2 1/2	PH00LH025	PH00CH025	PH00KH025	UH00MH025	45
3 1/4	PH00LH032	PH00CH032	PH00KH032	UH00MH032	120
4	PH00LH040	PH00CH040	PH00KH040	UH00MH040	130
5	PH00LH050	PH00CH050	PH00KH050	UH00MH050	310
6	PH00LH060	PH00CH060	PH00KH060	UH00MH060	525

Bore Size	Class 5 Fluorocarbon			
	Piston Lipseal Kits (Contains: 2 Each Sym. #42, 44, & 47)	Piston Ring Kits (Contains: 4 Each Sym. #48 & 2 Each Sym. #47)	Hi-Load Piston Seal Kits (Contains: 2 Each Sym. #47, 119, 120, & 121)	Tie Rod Nut Specification Foot Lbs.* (-0%, +5% tolerance)
1 1/2	VH00LH015	VH00CH015	VH00KH015	18
2	VH00LH020	VH00CH020	VH00KH020	45
2 1/2	VH00LH025	VH00CH025	VH00KH025	45
3 1/4	VH00LH032	VH00CH032	VH00KH032	120
4	VH00LH040	VH00CH040	VH00KH040	130
5	VH00LH050	VH00CH050	VH00KH050	310
6	VH00LH060	VH00CH060	VH00KH060	525

* When assembling the cylinder, be sure to torque the tie rods evenly.

Rod Gland and Rod Seal Kits

Rod Dia.	Class 1 Polyurethane & Buna-N		Retainer Screw Torque Inch Lbs. (-0%, +5% tolerance)
	Rod Gland Kits (Contains: 1 Each Sym. #14, 40, 41, & 45)	Rod Seal Kits (Contains: 1 Each Sym. #40, 41, & 45)	
5/8	PH06RH000	PH06SH000	24
1	PH10RH000	PH10SH000	24
1 3/8	PH13RH000	PH13SH000	24
1 3/4	PH17RH000	PH17SH000	24
2	PH20RH000	PH20SH000	120
2 1/2	PH25RH000	PH25SH000	120
3	PH30RH000	PH30SH000	240
3 1/2	PH35RH000	PH35SH000	240
4	PH40RH000	PH40SH000	240

Rod Dia.	Class 5 Fluorocarbon		Retainer Screw Torque Inch Lbs. (-0%, +5% tolerance)
	Rod Gland Kits (Contains: 1 Each Sym. #14, 40, 41, 43*, & 45)	Rod Seal Kits (Contains: 1 Each Sym. #40, 41, 43*, & 45)	
5/8	VH06RH000	VH06SH000	24
1	VH10RH000	VH10SH000	24
1 3/8	VH13RH000	VH13SH000	24
1 3/4	VH17RH000	VH17SH000	24
2	VH20RH000	VH20SH000	120
2 1/2	VH25RH000	VH25SH000	120
3	VH30RH000	VH30SH000	240
3 1/2	VH35RH000	VH35SH000	240
4	VH40RH000	VH40SH000	240

* Item 43 not required for 5/8" & 1" rod diameter.

7" and 8" Bore Sizes

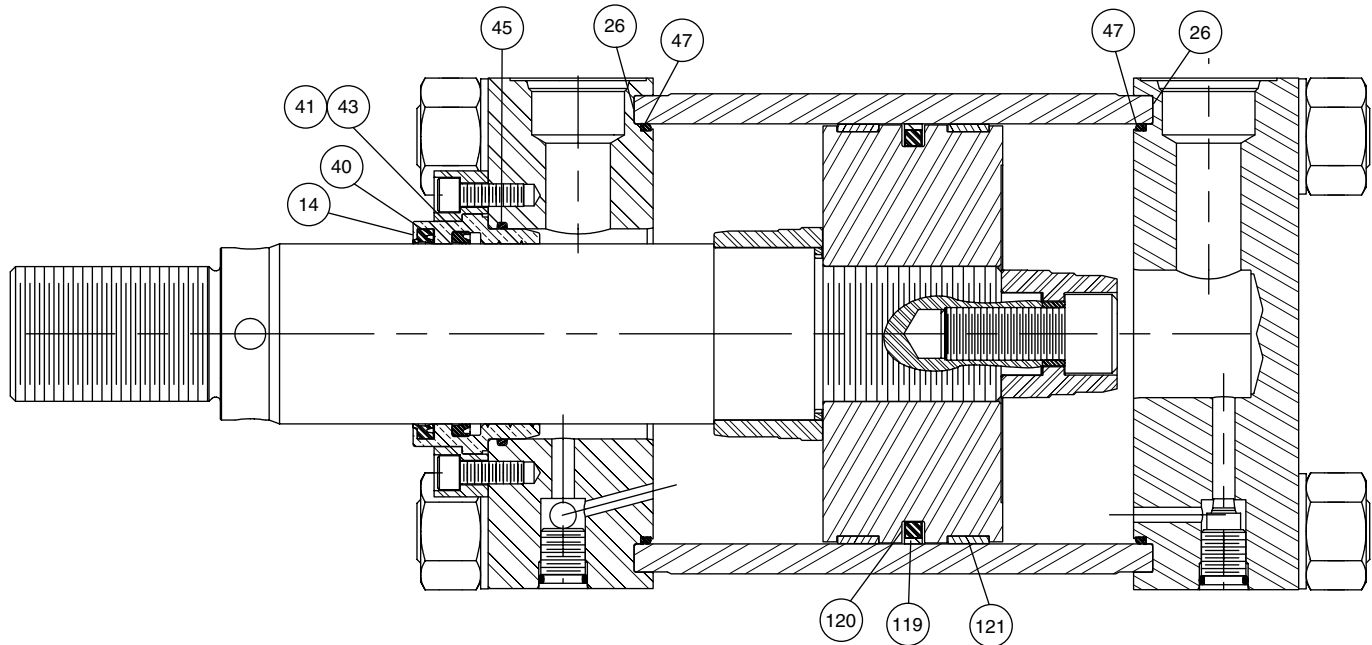

Parts Identification

Sym. No.	Description	Sym. No.	Description
14	Rod Bearing	47	End Seal O-Ring
40	Rod Wiper	48	Piston Ring
41	Rod Seal	62	Bushing Kit
43	Rod Seal Back Up Washer	119	Outer Ring
26	End Seal Back Up Washer	120	Inner Ring
45	Gland to Head O-Ring	121	Wear Ring

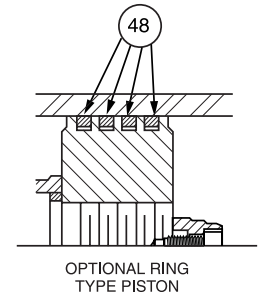

Rod Gland and Rod Seal Kits

Rod Dia.	Class 1 Polyurethane & Buna-N		Class 5 Service Fluorocarbon		Retainer Screw Torque Inch Lbs. (-0%, +5% tolerance)
	Rod Gland Kits (Contains: 1 Each Sym. #14, 40, 41, & 45)	Rod Seal Kits (Contains: 1 Each Sym. #40, 41, & 45)	Rod Gland Kits (Contains: 1 Each Sym. #14, 40, 41, 43, & 45)	Rod Seal Kits (Contains: 1 Each Sym. #40, 41, 43, & 45)	
3	PH30RH000	PH30SH000	VH30RH000	VH30SH000	240
3 1/2	PH35RH000	PH35SH000	VH35RH000	VH35SH000	240
4	PH40RH000	PH40SH000	VH40RH000	VH40SH000	240
5	PH50RH000	PH50SH000	VH50RH000	VH50SH000	240
5 1/2	PH55RH000	PH55SH000	VH55RH000	VH55SH000	240

Piston Seal Kits

Bore Size	Class 1 & 2 Buna-N			Class 5 Fluorocarbon		Tie Rod Nut Specification Foot Lbs.* (-0%, +5% tolerance)
	Piston Ring Kits (Contains: 4 Each Sym. #48 & 2 Each Sym. #26 & 47)	Hi-Load Piston Seal Kits (Contains: 2 Each Sym. #26, 47, & 121 2 Each Sym. #119 & 120)	Poly Flex Piston Seal Kits (Contains: 2 Each Sym. #26, 42, 44, & 47)	Piston Ring Kits (Contains: 4 Each Sym. #48 & 2 Each Sym. #26 & 47)	Hi-Load Piston Seal Kits (Contains: 2 Each Sym. #26, 47, & 121 2 Each Sym. #119 & 120)	
7	PH00CH070	PH00KH070	UH00MH070	VH00CH070	VH00KH070	800
8	PH00CH080	PH00KH080	UH00MH080	VH00CH080	VH00KH080	1168

* When assembling the cylinder, be sure to torque the tie rods evenly.

NOTES

10" through 20" Bore Sizes

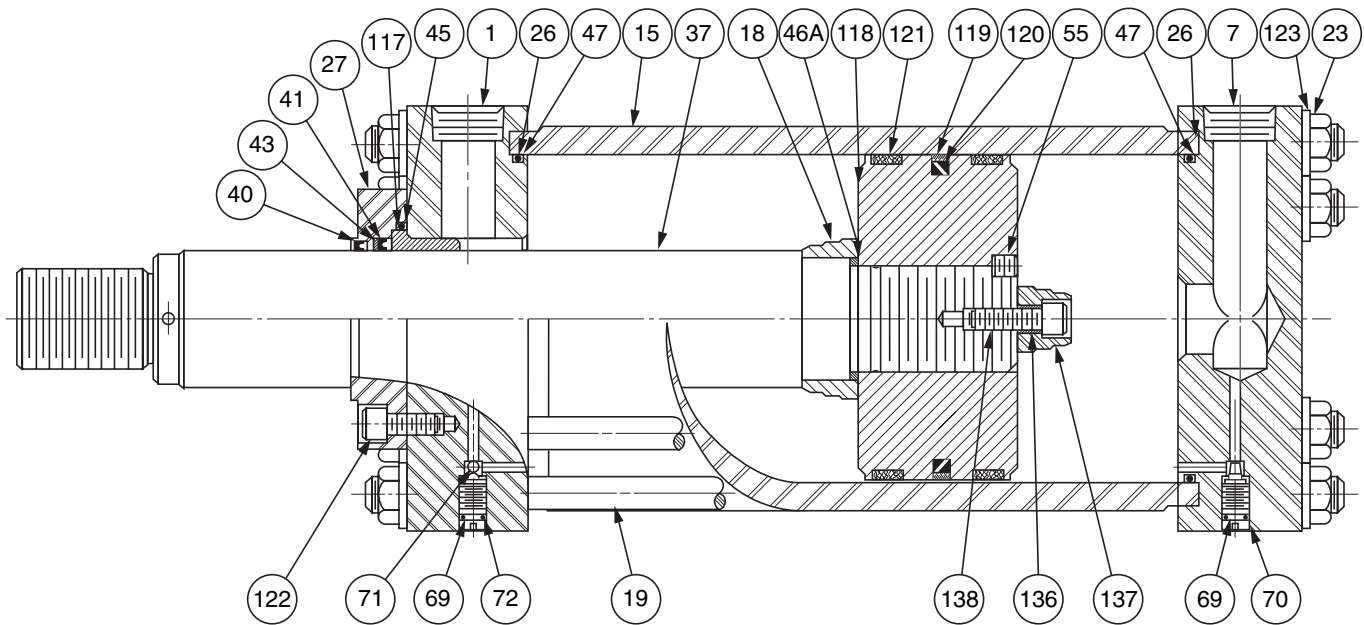

Sym. No.	
1	Head
7	Cap
15	Cylinder Body
16	Piston Body – Ring Type Piston
18	Cushion Sleeve
19	Tie Rod
23	Tie Rod Nut – Non-Locking
26	Back-Up Washer, Cylinder Body
27	Retainer
37	Piston Rod
40	Wiperseal
41	Rod Seal (Polypak)
43	Back-Up Washer, Polypak
45	O-Ring, Gland to Head
46A	Cushion Sealing Ring
47	O-Ring Cylinder Body

Sym. No.	
48	Piston Ring
55	Piston Lock Pin
69	O-Ring, Cushion Adj. & Check Screws
70	Cushion Adjusting Needle Screw
71	Check Valve Ball
72	Check Valve Screw
117	Rod Bearing
118	Piston Body – Hi-Load
119	Outer Piston Ring
120	Inner Piston Ring
121	Wear Ring
122	Retainer Bolt
123	Washer, Tie Rod Nut
136	Spacer, Cushion
137	Cushion Spear, Detachable
138	Bolt, Cushion Spear

10" through 20" Bore Sizes

Optional Cast Iron
Piston Ring Kit

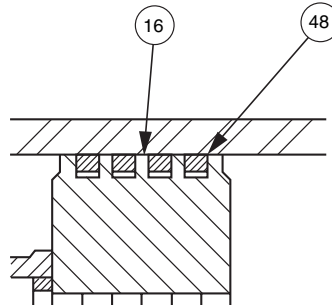

Operating fluids and temperature range – Fluidpower cylinders are designed for use with pressurized air, hydraulic oil and fire resistant fluids, in some cases special seals are required.

Buna-N

Buna-N seals are supplied on all standard pneumatic and hydraulic cylinders. They are suitable for use with pressured air, nitrogen, hydraulic oil, water-in oil emulsions or water glycol fluids. The recommended operating temperature range for Buna-N seals is -10°F. (-23°C.) to +165°F (+74°C.).

Fluorocarbon seals

Fluorocarbon seals can be supplied, on request, and are especially suitable for some fire resistant fluids as shown in the table on page 57 or for elevated temperature service.

When using Fluorocarbon seals for high temperature service or fluid compatibility within a temperature range of -10°F. (-23°C) to +250°F. (+121°C) specify Class 5 seals.

For elevated temperature service above +250°F. (+121°C) specify Class 5 seals. Class 5 seals can operate up to a maximum of +400°F. (+204°C) with reduced service life.

Rod Gland and Rod Seal Kits

Rod Dia.	Class 1 Polyurethane & Buna-N		Class 5 Service Fluorocarbon		Retainer Bolt Torque Foot Lbs. (-0%, +5% tolerance)
	Rod Gland Kits (Contains: 1 Each Sym. #40, 41, 43, 45 & 117)	Rod Seal Kits (Contains: 1 Each Sym. #40, 41, 43, & 45)	Rod Gland Kits (Contains: 1 Each Sym. #40, 41, 43, 45 & 117)	Rod Seal Kits (Contains: 1 Each Sym. #40, 41, 43, & 45)	
4 1/2	PH45RH005	PH45SH005	VH45RH005	VH45SH005	40
5	PH50RH005	PH50SH005	VH50RH005	VH50SH005	46
5 1/2	PH55RH005	PH55SH005	VH55RH005	VH55SH005	46
7	PH70RH005	PH70SH005	VH70RH005	VH70SH005	40
8	PH80RH005	PH80SH005	VH80RH005	VH80SH005	180
9	PH90RH005	PH90SH005	VH90RH005	VH90SH005	180
10	PH1LRH005	PH1LSH005	VH1LRH005	VH1LSH005	180

Piston Seal Kits

Bore Size	Class 1 & 2 Buna-N			Class 5 Fluorocarbon		Tie Rod Nut Specification Foot Lbs.* (-0%, +5% tolerance)
	Piston Ring Kits (Contains: 4 Each Sym. #48 & 2 Each Sym. #47 & 26)	Hi-Load Piston Seal Kits (Contains: 2 Each Sym. #47 & 121 1 Each Sym. #119 & 120)	Poly Flex Piston Seal Kits (Contains: 2 Each Sym. #42, 44, & 47)	Piston Ring Kits (Contains: 4 Each Sym. #48 & 2 Each Sym. #47)	Hi-Load Piston Seal Kits (Contains: 2 Each Sym. #47 & 121 1 Each Sym. #119 & 120)	
10	PH00CH100	PH00KH100	UH00MH100	VH00CH100	VH00KH100	700
12	PH00CH120	PH00KH120	UH00MH120	VH00CH120	VH00KH120	1320
14	PH00CH140	PH00KH140	UH00MH140	VH00CH140	VH00KH140	1000
16 - 20	Consult Factory					3000

* When assembling the cylinder, be sure to torque the tie rods evenly.

How to Order Series H Cylinders

Data Required On All Cylinder Orders

When ordering Series H cylinders, be sure to specify each of the following requirements:

(NOTE: – Duplicate cylinders can be ordered by giving the SERIAL NUMBER from the original cylinder. Factory records supply a quick, positive identification.)

- | | |
|---|---|
| <ol style="list-style-type: none"> 1. Series Designation (“H”) 2. Bore 3. Style Option (X for double rod or Y for duplex designs, blank otherwise) 4. Mounting Style
Specify your choice of mounting as shown and dimensioned in this catalog. 5. Piston Rod Diameter
Call out rod diameter. Standard (smallest) rod diameter will be furnished if not specified, unless stroke length makes the application questionable. 6. Piston Rod End Style
Call out the rod end style or specify dimensions if non-standard. Rod end style 1 will be furnished if not specified. 7. Cushions
Specify cushions if required and at which end, using the codes provided. If double rod end with only one end cushioned, be sure to clearly indicate which end. | <ol style="list-style-type: none"> 8. Ports
Atlas recommends SAE straight thread ports for leak-proof connections on Series “H” hydraulic cylinders. 9. Seals
Nitrile piston seals, the Atlas “Tri-Lip” Enhanced Polyurethane rod seal, Buna-N static seals and a wiper seal are all standard, for use with mineral oil based hydraulic fluids. Fluorocarbon, EPR, Nitroxile and other compounds can be specified, subject to application temperature range and fluid used. Cast iron piston rings or low friction PTFE piston seals can be specified in the special options section. 10. Stroke
Specify length required. 11. Special Options
Specify. Consult factory for questions. |
|---|---|

Sample Model Code

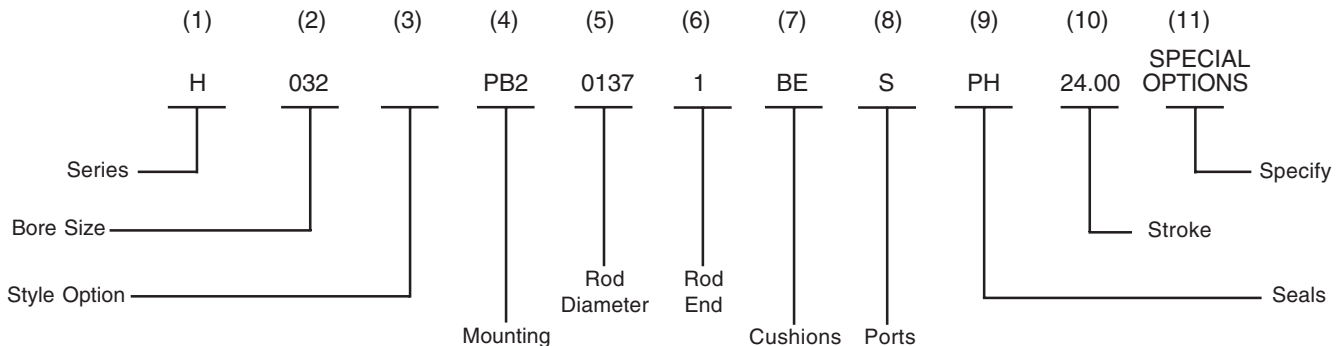

NOTE: On double rod end cylinders, repeat rod size and specify rod end threads for each side.
 For duplex cylinders, the entire model code for each cylinder should be included and indicated as "back to back" or "rod to rod."
 If replacing existing cylinder or ordering parts, include the serial number.

Style 4 Rod End

A style 4 rod end indicates a special rod end configuration. All special rod ends must be described by at least **all three**: KK; A; or W/WF specified with the rod fully retracted. A sketch or drawing should be submitted for rod ends requiring special machining such as snap ring grooves,

keyways, tapers, multiple diameters, etc. It is good design practice to have this machining done on a diameter at least 0.065 inches smaller than the piston rod diameter. This allows the piston rod to have a chamfer preventing rod seal damage during assembly or maintenance.

Service Policy

When cylinders are returned to the factory for repairs, it is standard policy for Atlas Cylinders to make such part replacements as will put the cylinder in as good as new condition. Should the condition of the returned cylinder be such that expenses for repair exceed the cost of a new one, you will be notified.

Certified Dimensions

Atlas Cylinders guarantees that all cylinders ordered from this catalog will be built to dimensions shown. All dimensions are certified to be correct, and thus it is not necessary to request certified drawings.

Series H Ordering Guide

(1) SERIES	(2) BORE	(3) STYLE	(4) MOUNT	(5) ROD	(6) ROD END	(7) CUSHIONS	(8) PORTS	(9) SEALS	(10) STROKE	(11) OPTIONS
<i>H</i>	015 (1.50")	<i>(Leave</i>	BEF1	See "Piston Rod Selection Chart"	1 (<i>KK Male</i>)	NC (<i>None</i>)	S (<i>SAE</i>)	See "Operating Fluids" on page 57.	XXX.XX	S*
<i>*HA</i>	020 (2.00")	<i>Blank</i>	BEF2		2 (CC Male)	HE (Head End)	N (NPTF)		(Specify Gross Stroke if Stop Tube is Required)	(See Below)
<i>*HL</i>	025 (2.50")	<i>if</i>	FS	on page 64.	3 (KK Female)	CE (Cap End)	I (ISO 6149)			
HW	032 (3.25")	Standard	IH3	0062 (.63")	4 (Special†)	BE (Both Ends)	F (Flange)	PH Standard Tri-Lip Rod Seal, Nitrile Piston Lipseals (Class 1 Seals)		
	040 (4.00")		IH4	0100 (1.00")	5 (Split Coupler)		X (Other)			
	050 (5.00")	X	ME5	0137 (1.38")	6 (Stub End)		(Specify)			
	060 (6.00")	(Double Rod End)	ME6	0175 (1.75")				VH Fluorocarbon Seals (Class 5 Seals)		
	070 (7.00")		NM1	0200 (2.00")						
	080 (8.00")		NM2	0250 (2.50")	† Must Specify:					
	100 (10.0")	Y	NM3	0300 (3.00")	WF (Rod Extension)			EH EPR Seals (Class 3 Seals)		
	120 (12.0")	(Duplex)	PB2	0350 (3.50")	A (Thread Length)			BH H.W.C.F. (Class 6 Seals)		
	140 (14.0")		REF1	0400 (4.00")	KK (Thread Size and Pitch)			MH Class 1 Seals with Brass Scraper		
	160 (16.0")		REF2	0450 (4.50")				HH Spring Loaded PTFE Seals (Class 8 Seals)		
	180 (18.0")		SA	0500 (5.00")				UH Standard Tri-Lip Rod Seal, Polyurethane Poly Flex Piston Seals		
	200 (20.0")		SL	0550 (5.50")				XH Special - Specify		
			TM1	0700 (7.00")						
			TM2	0800 (8.00")						
			TM3	1000 (10.0")						
			(specify dimension XI)							

**HA* is the same cylinder supplied for pneumatic service with a chrome plated barrel I.D.
HL is also for pneumatic service with chromed barrel, but prelubricated.
HW – Wood Products H Cylinder (available 1½" - 8" bores) – see below

S* The letter S refers to special options or modifications that deviate from the standard product offering. Non-standard modifications and options not identified in the cylinder model number should be added in the notes when placing an order.

Modifications which can be placed under the designator "S" are as follows:

- End-of-Stroke Switches
 - EPS-5, EPS-6, EPS-7, CLS-1, CLS-4 Styles (See bulletin AC0840-B11)
 - MagnaSwitch

- Gland Wear Ring
- Hi-Load Piston (1½"-6" Bores)
- Polymyte Rod Wiperseal

Note: The standard #1 port location is at the top of the cylinder, and the standard cushion adjustment screw is in position #2 when facing the rod end of the cylinder. If multiple ports are required, the last character of the part number should be "S", indicating modified and the desired port location specified in the notes.

Cylinders for Wood Products Applications

Atlas Cylinders has built a solid reputation in the Wood Products Industry where demanding applications require a cylinder that is up to the task. That is why we offer an option that makes Atlas Cylinders the most dependable and long lasting actuator for Timber Industry service.

❖ **Set screw piston to piston rod**

Two axial screws in the piston-to-rod joint prevent the assembly from unthreading.

❖ **Polyurethane rod wiperseal**

Durable rod wiperseal cleans any oil adhering to the rod on the extend stroke and wipes the rod on the return stroke.

❖ **'Solid' cap end cushion**

Cushion machined directly in the cap for improved resistance to pressure spikes. High flow ball check valves for quick out-of-cushion performance.

❖ **Poly Flex Piston Seals**

Durable polyurethane material with o-ring energizer for long life and positive sealing.

To order your Atlas cylinder with the **Wood Products** options (available 1½"-8" bores) specify **'HW'** Series and **'UH'** in the seal field of the model code. See the example below.

HW	032	PB2	0137	1	BE	S	UH	10.000
Series	Bore	Mount	Rod	Rod End	Cushions	Ports	Seals	Stroke

Safety Guide for Selecting and Using Hydraulic, Pneumatic Cylinders and Their Accessories

WARNING: ⚠ FAILURE OF THE CYLINDER, ITS PARTS, ITS MOUNTING, ITS CONNECTIONS TO OTHER OBJECTS, OR ITS CONTROLS CAN RESULT IN:

- Unanticipated or uncontrolled movement of the cylinder or objects connected to it.
- Falling of the cylinder or objects held up by it.
- Fluid escaping from the cylinder, potentially at high velocity.

THESE EVENTS COULD CAUSE DEATH OR PERSONAL INJURY BY, FOR EXAMPLE, PERSONS FALLING FROM HIGH LOCATIONS, BEING CRUSHED OR STRUCK BY HEAVY OR FAST MOVING OBJECTS, BEING PUSHED INTO DANGEROUS EQUIPMENT OR SITUATIONS, OR SLIPPING ON ESCAPED FLUID.

Before selecting or using Atlas (The Company) cylinders or related accessories, it is important that you read, understand and follow the following safety information. Training is advised before selecting and using The Company's products.

1.0 General Instructions

1.1 Scope – This safety guide provides instructions for selecting and using (including assembling, installing, and maintaining) cylinder products. This safety guide is a supplement to and is to be used with the specific Company publications for the specific cylinder products that are being considered for use.

1.2 Fail Safe – Cylinder products can and do fail without warning for many reasons. All systems and equipment should be designed in a fail-safe mode so that if the failure of a cylinder product occurs people and property won't be endangered.

1.3 Distribution – Provide a free copy of this safety guide to each person responsible for selecting or using cylinder products. Do not select or use The Company's cylinders without thoroughly reading and understanding this safety guide as well as the specific Company publications for the products considered or selected.

1.4 User Responsibility – Due to very wide variety of cylinder applications and cylinder operating conditions, The Company does not warrant that any particular cylinder is suitable for any specific application. This safety guide does not analyze all technical parameters that must be considered in selecting a product. The hydraulic and pneumatic cylinders outlined in this catalog are designed to The Company's design guidelines and do not necessarily meet the design guideline of other agencies such as American Bureau of Shipping, ASME Pressure Vessel Code etc. The user, through its own analysis and testing, is solely responsible for:

- Making the final selection of the cylinders and related accessories.
- Determining if the cylinders are required to meet specific design requirements as required by the Agency(s) or industry standards covering the design of the user's equipment.
- Assuring that the user's requirements are met, OSHA requirements are met, and safety guidelines from the applicable agencies such as but not limited to ANSI are followed and that the use presents no health or safety hazards.
- Providing all appropriate health and safety warnings on the equipment on which the cylinders are used.

1.5 Additional Questions – Call the appropriate Company technical service department if you have any questions or require any additional information. See the Company publication for the product being considered or used, or call the number on the back cover of this catalog for the technical service department.

2.0 Cylinder and Accessories Selection

2.1 Seals – Part of the process of selecting a cylinder is the selection of seal compounds. Before making this selection, consult the "seal information page(s)" of the publication for the series of cylinders of interest.

The application of cylinders may allow fluids such as cutting fluids, wash down fluids etc. to come in contact with the external area of the cylinder. These fluids may attack the piston rod wiper and or the primary seal and must be taken into account when selecting and specifying seal compounds.

Dynamic seals will wear. The rate of wear will depend on many operating factors. Wear can be rapid if a cylinder is mis-aligned or if the cylinder has been improperly serviced. The user must take seal wear into consideration in the application of cylinders.

2.2 Piston Rods – Possible consequences of piston rod failure or separation of the piston rod from the piston include, but are not limited to are:

- Piston rod and or attached load thrown off at high speed.
- High velocity fluid discharge.
- Piston rod extending when pressure is applied in the piston retract mode.

Piston rods or machine members attached to the piston rod may move suddenly and without warning as a consequence of other conditions occurring to the machine such as, but not limited to:

- Unexpected detachment of the machine member from the piston rod.

- Failure of the pressurized fluid delivery system (hoses, fittings, valves, pumps, compressors) which maintain cylinder position.
- Catastrophic cylinder seal failure leading to sudden loss of pressurized fluid.
- Failure of the machine control system.

Follow the recommendations of the "Piston Rod Selection Chart and Data" in the publication for the series of cylinders of interest. The suggested piston rod diameter in these charts must be followed in order to avoid piston rod buckling.

Piston rods are not normally designed to absorb bending moments or loads which are perpendicular to the axis of piston rod motion. These additional loads can cause the piston rod to fail. If these types of additional loads are expected to be imposed on the piston rod, their magnitude should be made known to our engineering department.

The cylinder user should always make sure that the piston rod is securely attached to the machine member.

On occasion cylinders are ordered with double rods (a piston rod extended from both ends of the cylinder). In some cases a stop is threaded on to one of the piston rods and used as an external stroke adjuster. On occasions spacers are attached to the machine member connected to the piston rod and also used as a stroke adjuster. In both cases the stops will create a pinch point and the user should consider appropriate use of guards. If these external stops are not perpendicular to the mating contact surface, or if debris is trapped between the contact surfaces, a bending moment will be placed on the piston rod, which can lead to piston rod failure. An external stop will also negate the effect of cushioning and will subject the piston rod to impact loading. Those two (2) conditions can cause piston rod failure. Internal stroke adjusters are available with and without cushions. The use of external stroke adjusters should be reviewed with our engineering department.

The piston rod to piston and the stud to piston rod threaded connections are secured with an anaerobic adhesive. The strength of the adhesive decreases with increasing temperature. Cylinders which can be exposed to temperatures above +250°F (+121°C) are to be ordered with a non studded piston rod and a pinned piston to rod joint.

2.3 Cushions – Cushions should be considered for cylinder applications when the piston velocity is expected to be over 4 inches/second.

Cylinder cushions are normally designed to absorb the energy of a linear applied load. A rotating mass has considerably more energy than the same mass moving in a linear mode. Cushioning for a rotating mass application should be reviewed by our engineering department.

2.4 Cylinder Mountings – Some cylinder mounting configurations may have certain limitations such as but not limited to minimum stroke for side or foot mounting cylinders or pressure de-ratings for certain mounts. Carefully review the catalog for these types of restrictions.

Always mount cylinders using the largest possible high tensile alloy steel socket head cap screws that can fit in the cylinder mounting holes and torque them to the manufacturer's recommendations for their size.

2.5 Port Fittings – Hydraulic cylinders applied with meter out or deceleration circuits are subject to intensified pressure at piston rod end.

The rod end pressure is approximately equal to:

$$\frac{\text{operating pressure} \times \text{effective cap end area}}{\text{effective rod end piston area}}$$

Contact your connector supplier for the pressure rating of individual connectors.

3.0 Cylinder and Accessories Installation and Mounting

3.1 Installation

3.1.1 – Cleanliness is an important consideration, and cylinders are shipped with the ports plugged to protect them from contaminants entering the ports. These plugs should not be removed until the piping is to be installed. Before making the connection to the cylinder ports, piping should be thoroughly cleaned to remove all chips or burrs which might have resulted from threading or flaring operations.

3.1.2 – Cylinders operating in an environment where air drying materials are present such as fast-drying chemicals, paint, or weld splatter, or other hazardous conditions such as excessive heat, should have shields installed to prevent damage to the piston rod and piston rod seals.

3.1.3 – Proper alignment of the cylinder piston rod and its mating component on the machine should be checked in both the extended and retracted positions. Improper alignment will result in excessive rod gland and/or cylinder bore wear. On fixed mounting cylinders attaching the piston rod while the rod is retracted will help in achieving proper alignment.

3.1.4 – Sometimes it may be necessary to rotate the piston rod in order to thread the piston rod into the machine member. This operation must always be done with zero pressure being applied to either side of the piston. Failure to follow this procedure may result in loosening the piston to rod-threaded connection. In some rare cases the turning of the piston rod may rotate a threaded piston rod gland and loosen it from the cylinder head. Confirm that this condition is not occurring. If it does, re-tighten the piston rod gland firmly against the cylinder head.

For double rod cylinders it is also important that when attaching or detaching the piston rod from the machine member that the torque be applied to the piston rod end of the cylinder that is directly attaching to the machine member with the opposite end unrestrained. If the design of the machine is such that only the rod end of the cylinder opposite to where the rod attaches to the machine member can be rotated, consult the factory for further instructions.

3.2 Mounting Recommendations

3.2.1 – Always mount cylinders using the largest possible high tensile alloy steel socket head screws that can fit in the cylinder mounting holes and torque them to the manufacturer's recommendations for their size.

3.2.2 – Side-Mounted Cylinders – In addition to the mounting bolts, cylinders of this type should be equipped with thrust keys or dowel pins located so as to resist the major load.

3.2.3 – Tie Rod Mounting – Cylinders with tie rod mountings are recommended for applications where mounting space is limited. The standard tie rod extension is shown as BB in dimension tables. Longer or shorter extensions can be supplied. Nuts used for this mounting style should be torqued to the same value as the tie rods for that bore size.

3.2.4 – Flange Mount Cylinders – The controlled diameter of the rod gland extension on head end flange mount cylinders can be used as a pilot to locate the cylinders in relation to the machine. After alignment has been obtained, the flanges may be drilled for pins or dowels to prevent shifting.

3.2.5 – Trunnion Mountings – Cylinders require lubricated bearing blocks with minimum bearing clearances. Bearing blocks should be carefully aligned and rigidly mounted so the trunnions will not be subjected to bending moments. The rod end should also be pivoted with the pivot pin in line and parallel to axis of the trunnion pins.

3.2.6 – Clevis Mountings – Cylinders should be pivoted at both ends with centerline of pins parallel to each other. After cylinder is mounted, be sure to check to assure that the cylinder is free to swing through its working arc without interference from other machine parts.

4.0 Cylinder and Accessories Maintenance, Troubleshooting and Replacement

4.1 Storage – At times cylinders are delivered before a customer is ready to install them and must be stored for a period of time. When storage is required the following procedures are recommended.

4.1.1 – Store the cylinders in an indoor area which has a dry, clean and noncorrosive atmosphere. Take care to protect the cylinder from both internal corrosion and external damage.

4.1.2 – Whenever possible cylinders should be stored in a vertical position (piston rod up). This will minimize corrosion due to possible condensation which could occur inside the cylinder. This will also minimize seal damage.

4.1.3 – Port protector plugs should be left in the cylinder until the time of installation.

4.1.4 – If a cylinder is stored full of hydraulic fluid, expansion of the fluid due to temperature changes must be considered. Installing a check valve with free flow out of the cylinder is one method.

4.1.5 – When cylinders are mounted on equipment that is stored outside for extended periods, exposed unpainted surfaces, e.g. piston rod, must be coated with a rust-inhibiting compound to prevent corrosion.

4.2 Cylinder Trouble Shooting

4.2.1 – External Leakage

4.2.1.1 – Rod seal leakage can generally be traced to worn or damaged seals. Examine the piston rod for dents, gouges or score marks, and replace piston rod if surface is rough.

Rod seal leakage could also be traced to gland wear. If clearance is excessive, replace rod bushing and seal. Rod seal leakage can also be traced to seal deterioration. If seals are soft or gummy or brittle, check compatibility of seal material with lubricant used if air cylinder, or operating fluid if hydraulic cylinder. Replace with seal material, which is compatible with these fluids. If the seals are hard or have lost elasticity, it is usually due to exposure to temperatures in excess of 165°F. (+74°C). Shield the cylinder from the heat source to limit temperature to 350°F. (+177°C.) and replace with fluorocarbon seals.

4.2.1.2 – Cylinder body seal leak can generally be traced to loose tie rods. Torque the tie rods to manufacturer's recommendation for that bore size.

Excessive pressure can also result in cylinder body seal leak. Determine maximum pressure to rated limits. Replace seals and retorque tie rods as in paragraph above. Excessive pressure can also result in cylinder body seal leak. Determine if the pressure rating of the cylinder has been exceeded. If so, bring the operating pressure down to the rating of the cylinder and have the tie rods replaced.

Pinched or extruded cylinder body seal will also result in a leak. Replace cylinder body seal and retorque as in paragraph above.

Cylinder body seal leakage due to loss of radial squeeze which shows up in the form of flat spots or due to wear on the O.D. or I.D. – Either of these are symptoms of normal wear due to high cycle rate or length of service. Replace seals as per paragraph above.

4.2.2 – Internal Leakage

4.2.2.1 – Piston seal leak (by-pass) 1 to 3 cubic inches per minute leakage is considered normal for piston ring construction. Virtually no static leak with lipseal type seals on piston should be expected. Piston seal wear is a usual cause of piston seal leakage. Replace seals as required.

4.2.2.2 – With lipseal type piston seals excessive back pressure due to over-adjustment of speed control valves could be a direct cause of rapid seal wear. Contamination in a hydraulic system can result in a scored cylinder bore, resulting in rapid seal wear. In either case, replace piston seals as required.

4.2.2.3 – What appears to be piston seal leak, evidenced by the fact that the cylinder drifts, is not always traceable to the piston. To make sure, it is suggested that one side of the cylinder piston be pressurized and the fluid line at the opposite port be disconnected. Observe leakage. If none is evident, seek the cause of cylinder drift in other component parts in the circuit.

4.2.3 – Cylinder Fails to Move the Load

4.2.3.1 – Pneumatic or hydraulic pressure is too low. Check the pressure at the cylinder to make sure it is to circuit requirements.

4.2.3.2 – Piston Seal Leak – Operate the valve to cycle the cylinder and observe fluid flow at valve exhaust ports at end of cylinder stroke. Replace piston seals if flow is excessive.

4.2.3.3 – Cylinder is undersized for the load – Replace cylinder with one of a larger bore size.

4.3 Erratic or Chatter Operation

4.3.1 – Excessive friction at rod gland or piston bearing due to load misalignment – Correct cylinder-to-load alignment.

4.3.2 – Cylinder sized too close to load requirements – Reduce load or install larger cylinder.

4.3.3 – Erratic operation could be traced to the difference between static and kinetic friction. Install speed control valves to provide a back pressure to control the stroke.

4.4 Cylinder Modifications, Repairs, or Failed Component – Cylinders as shipped from the factory are not to be disassembled and or modified. If cylinders require modifications, these modifications must be done at company locations or by The Company's certified facilities. The Cylinder Division Engineering Department must be notified in the event of a mechanical fracture or permanent deformation of any cylinder component (excluding seals). This includes a broken piston rod, tie rod, mounting accessory or any other cylinder component. The notification should include all operation and application details. This information will be used to provide an engineered repair that will prevent recurrence of the failure.

It is allowed to disassemble cylinders for the purpose of replacing seals or seal assemblies. However, this work must be done by strictly following all the instructions provided with the seal kits.

NOTES

NOTES

NOTES

WARNING

FAILURE OR IMPROPER SELECTION OR IMPROPER USE OF THE PRODUCTS AND/OR SYSTEMS DESCRIBED HEREIN OR RELATED ITEMS CAN CAUSE DEATH, PERSONAL INJURY AND PROPERTY DAMAGE.

This document and other information from The Company, its subsidiaries and authorized distributors provide product and/or system options for further investigation by users having technical expertise. It is important that you analyze all aspects of your application, including consequences of any failure and review the information concerning the product or system in the current product catalog. Due to the variety of operating conditions and applications for these products or systems, the user, through its own analysis and testing, is solely responsible for making the final selection of the products and systems and assuring that all performance, safety and warning requirements of the application are met.

The product described herein, including without limitation, product features, specifications, designs, availability and pricing, are subject to change by The Company and its subsidiaries at any time without notice.

Offer of Sale

The items described in this document and other documents or descriptions provided by Parker Hannifin Corporation, its subsidiaries and Divisions ("Company") and its authorized distributors, are hereby offered for sale at prices to be established by the Company, its subsidiaries and its authorized distributors. This offer and its acceptance by any customer ("Buyer") shall be governed by all of the following Terms and Conditions. Buyer's order for any such item, when communicated to the Company, its subsidiary or an authorized distributor ("Seller") verbally or in writing, shall constitute acceptance of this offer.

1. Terms and Conditions of Sale: All descriptions, quotations, proposals, offers, acknowledgments, acceptances and sales of Seller's products are subject to and shall be governed exclusively by the terms and conditions stated herein. Buyer's acceptance of any offer to sell is limited to these terms and conditions. Any terms or conditions in addition to, or inconsistent with those stated herein, proposed by Buyer in any acceptance of an offer by Seller, are hereby objected to. No such additional, different or inconsistent terms and conditions shall become part of the contract between Buyer and Seller unless expressly accepted in writing by Seller. Seller's acceptance of any offer to purchase by Buyer is expressly conditional upon Buyer's assent to all the terms and conditions stated herein, including any terms in addition to, or inconsistent with those contained in Buyer's offer. Acceptance of Seller's products shall in all events constitute such assent.

2. Payment: Payment shall be made by Buyer net 30 days from the date of delivery of the items purchased hereunder. Amounts not timely paid shall bear interest at the maximum rate permitted by law for each month or portion thereof that the Buyer is late in making payment. Any claims by Buyer for omissions or shortages in a shipment shall be waived unless Seller receives notice thereof within 30 days after Buyer's receipt of the shipment.

3. Delivery: Unless otherwise provided on the face hereof, delivery shall be made F.O.B. Seller's plant. Regardless of the method of delivery, however, risk of loss shall pass to Buyer upon Seller's delivery to a carrier. Any delivery dates shown are approximate only and Seller shall have no liability for any delays in delivery.

4. Warranty: Seller warrants that the items sold hereunder shall be free from defects in material or workmanship for a period of 18 months from date of shipment from the Company. **THIS WARRANTY COMPRISES THE SOLE AND ENTIRE WARRANTY PERTAINING TO ITEMS PROVIDED HEREUNDER. SELLER MAKES NO OTHER WARRANTY, GUARANTEE, OR REPRESENTATION OF ANY KIND WHATSOEVER. ALL OTHER WARRANTIES, INCLUDING BUT NOT LIMITED TO, MERCHANTABILITY AND FITNESS FOR PURPOSE, WHETHER EXPRESS, IMPLIED, OR ARISING BY OPERATION OF LAW, TRADE USAGE, OR COURSE OF DEALING ARE HEREBY DISCLAIMED.**

NOTWITHSTANDING THE FOREGOING, THERE ARE NO WARRANTIES WHATSOEVER ON THE ITEMS BUILT OR ACQUIRED WHOLLY OR PARTIALLY, TO BUYER'S DESIGN OR SPECIFICATIONS.

5. Limitation of Remedy: SELLER'S LIABILITY ARISING FROM OR IN ANY WAY CONNECTED WITH THE ITEMS SOLD OR THIS CONTRACT SHALL BE LIMITED EXCLUSIVELY TO REPAIR OR REPLACEMENT OF THE ITEMS SOLD OR REFUND OF THE PURCHASE PRICE PAID BY BUYER, AT SELLER'S SOLE OPTION. IN NO EVENT SHALL SELLER BE LIABLE FOR ANY INCIDENTAL, CONSEQUENTIAL OR SPECIAL DAMAGES OF ANY KIND OR NATURE WHATSOEVER, INCLUDING BUT NOT LIMITED TO LOST PROFITS ARISING FROM OR IN ANY WAY CONNECTED WITH THIS AGREEMENT OR ITEMS SOLD HEREUNDER, WHETHER ALLEGED TO ARISE FROM BREACH OF CONTRACT, EXPRESS OR IMPLIED WARRANTY, OR IN TORT, INCLUDING WITHOUT LIMITATION, NEGLIGENCE, FAILURE TO WARN OR STRICT LIABILITY.

6. Changes, Reschedules and Cancellations: Buyer may request to modify the designs or specifications for the items sold hereunder as well as the quantities and delivery dates thereof, or may request to cancel all or part of this order, however, no such requested modification or cancellation shall become part of the contract between Buyer and Seller unless accepted by Seller in a written amendment to this Agreement. Acceptance of any such requested modification or cancellation shall be at Seller's discretion, and shall be upon such terms and conditions as Seller may require.

7. Special Tooling: A tooling charge may be imposed for any special tooling, including without limitations, dies, fixtures, molds and patterns, acquired to manufacture items sold pursuant to this contract. Such special tooling shall be and remain Seller's property notwithstanding payment of any charges by Buyer. In no event will Buyer acquire any interest in apparatus belonging to Seller which is utilized in the manufacture of the items sold hereunder, even if such apparatus has been specially converted or adapted for such manufacture and notwithstanding any charges paid by Buyer. Unless otherwise agreed, Seller shall have the right to alter, discard

or otherwise dispose of any special tooling or other property in its sole discretion at any time.

8. Buyer's Property: Any designs, tools, patterns, materials, drawings, confidential information or equipment furnished by Buyer, or any other items which become Buyer's property, may be considered obsolete and may be destroyed by Seller after two (2) consecutive years have elapsed without Buyer placing an order for the items which are manufactured using such property. Seller shall not be responsible for any loss or damage to such property while it is in Seller's possession or control.

9. Taxes: Unless otherwise indicated on the face hereof, all prices and charges are exclusive of excise, sales, use, property, occupational or like taxes which may be imposed by any taxing authority upon the manufacture, sale or delivery of the items sold hereunder. If any such taxes must be paid by Seller or if Seller is liable for the collection of such tax, the amount thereof shall be in addition to the amounts for the items sold. Buyer agrees to pay all such taxes or to reimburse Seller therefore upon receipt of its invoice. If Buyer claims exemption from any sales, use or other tax imposed by any taxing authority, Buyer shall save Seller harmless from and against any such tax, together with any interest or penalties thereon which may be assessed if the items are held to be taxable.

10. Indemnity For Infringement of Intellectual Property Rights: Seller shall have no liability for infringement of any patents, trademarks, copyrights, trade dress, trade secrets or similar rights except as provided in this Part 10. Seller will defend and indemnify Buyer against allegations of infringement of U.S. patents, U.S. trademarks, copyrights, trade dress and trade secrets (hereinafter "Intellectual Property Rights"). Seller will defend at its expense and will pay the cost of any settlement or damages awarded in an action brought against Buyer based on an allegation that an item sold pursuant to this contract infringes the Intellectual Property Rights of a third party. Seller's obligation to defend and indemnify Buyer is contingent on Buyer notifying Seller within ten (10) days after Buyer becomes aware of such allegations of infringement, and Seller having sole control over the defense of any allegations or actions including all negotiations for settlement or compromise. If an item sold hereunder is subject to a claim that it infringes the Intellectual Property Rights of a third party, Seller may, at its sole expense and option, procure for Buyer the right to continue using said item, replace or modify said item so as to make it noninfringing, or offer to accept return of said item and return the purchase price less a reasonable allowance for depreciation. Notwithstanding the foregoing, Seller shall have no liability for claims of infringement based on information provided by Buyer, or directed to items delivered hereunder for which the designs are specified in whole or part by Buyer, or infringements resulting from the modification, combination or use in a system of any item sold hereunder. The foregoing provisions of this Part 10 shall constitute Seller's sole and exclusive liability and Buyer's sole and exclusive remedy for infringement of Intellectual Property Rights.

If a claim is based on information provided by Buyer or if the design for an item delivered hereunder is specified in whole or in part by Buyer, Buyer shall defend and indemnify Seller for all costs, expenses or judgements resulting from any claim that such item infringes any patent, trademark, copyright, trade dress, trade secret or any similar right.

11. Force Majeure: Seller does not assume the risk of and shall not be liable for delay or failure to perform any of Seller's obligations by reason of circumstances beyond the reasonable control of Seller (hereinafter "Events of Force Majeure"). Events of Force Majeure shall include without limitation, accidents, acts of God, strikes or labor disputes, acts, laws, rules or regulations of any government or government agency, fires, floods, delays or failures in delivery of carriers or suppliers, shortages of materials and any other cause beyond Seller's control.

12. Entire Agreement/Governing Law: The terms and conditions set forth herein, together with any amendments, modifications and any different terms or conditions expressly accepted by Seller in writing, shall constitute the entire Agreement concerning the items sold, and there are no oral or other representations or agreements which pertain thereto. This Agreement shall be governed in all respects by the law of the State of Ohio. No actions arising out of sale of the items sold hereunder or this Agreement may be brought by either party more than two (2) years after the cause of action accrues.

ATLAS
CYLINDERS

500 S. Wolf Rd.
Des Plaines, IL 60016 USA
Tel.: (847) 298-2400
Fax.: (800) 892-1008
www.AtlasCylinders.com • atlasclmktg@parker.com